

JVC

SERVICE MANUAL

COMPACT COMPONENT SYSTEM

MX-DVB10

Area suffix

US ----- Singapore
 UX ----- Saudi Arabia
 UN ----- Asean

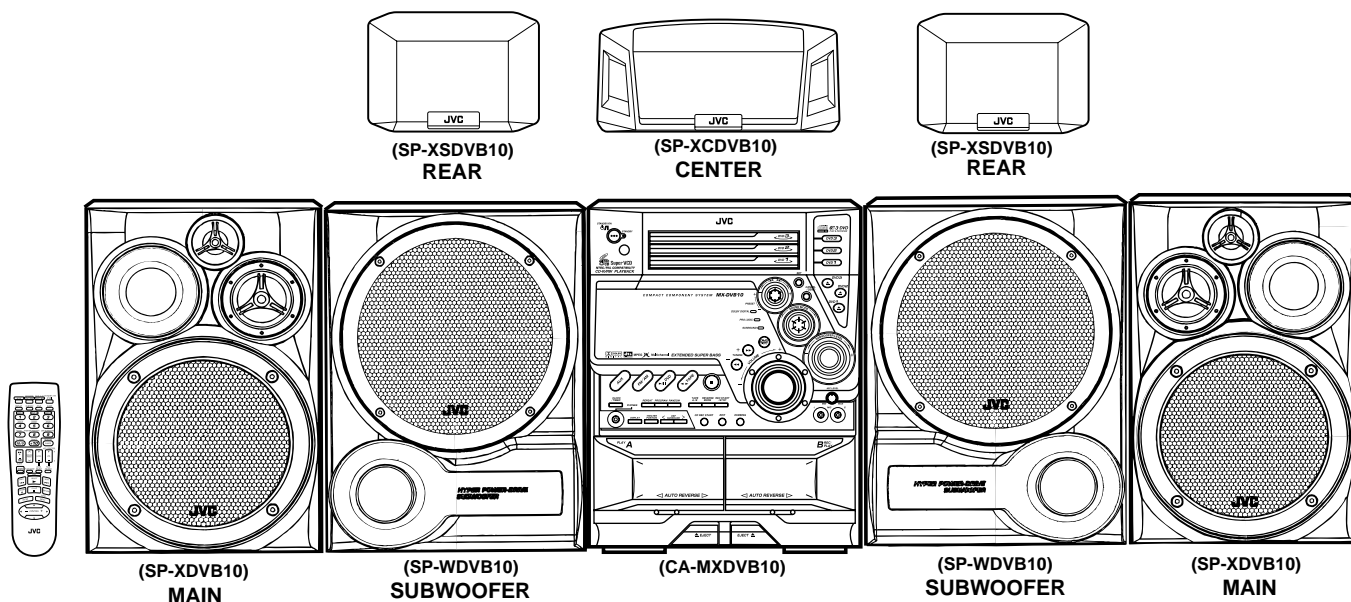

Contents

| | | | |
|-------------------------------------|------|-----------------------------------|---------|
| Safety precautions | 1-2 | Maintenance of laser pickup | 1-34 |
| Preventing static electricity | 1-3 | Replacement of laser pickup | 1-34 |
| Precautions for service | 1-4 | Flow of functional operation | |
| Important for laser products | 1-5 | until TOC read | 1-35 |
| Disassembly method | 1-6 | Description of major ICs | 1-36~70 |
| Adjustment method | 1-26 | | |

Safety Precautions

1. This design of this product contains special hardware and many circuits and components specially for safety purposes. For continued protection, no changes should be made to the original design unless authorized in writing by the manufacturer. Replacement parts must be identical to those used in the original circuits. Services should be performed by qualified personnel only.
2. Alterations of the design or circuitry of the product should not be made. Any design alterations of the product should not be made. Any design alterations or additions will void the manufacturers warranty and will further relieve the manufacture of responsibility for personal injury or property damage resulting therefrom.
3. Many electrical and mechanical parts in the products have special safety-related characteristics. These characteristics are often not evident from visual inspection nor can the protection afforded by them necessarily be obtained by using replacement components rated for higher voltage, wattage, etc. Replacement parts which have these special safety characteristics are identified in the Parts List of Service Manual. Electrical components having such features are identified by shading on the schematics and by (\triangle) on the Parts List in the Service Manual. The use of a substitute replacement which does not have the same safety characteristics as the recommended replacement parts shown in the Parts List of Service Manual may create shock, fire, or other hazards.
4. The leads in the products are routed and dressed with ties, clamps, tubings, barriers and the like to be separated from live parts, high temperature parts, moving parts and/or sharp edges for the prevention of electric shock and fire hazard. When service is required, the original lead routing and dress should be observed, and it should be confirmed that they have been returned to normal, after re-assembling.
5. Leakage current check (Electrical shock hazard testing)
After re-assembling the product, always perform an isolation check on the exposed metal parts of the product (antenna terminals, knobs, metal cabinet, screw heads, headphone jack, control shafts, etc.) to be sure the product is safe to operate without danger of electrical shock.
Do not use a line isolation transformer during this check.

- Plug the AC line cord directly into the AC outlet. Using a "Leakage Current Tester", measure the leakage current from each exposed metal parts of the cabinet, particularly any exposed metal part having a return path to the chassis, to a known good earth ground. Any leakage current must not exceed 0.5mA AC (r.m.s.).

- Alternate check method

Plug the AC line cord directly into the AC outlet. Use an AC voltmeter having, 1,000 ohms per volt or more sensitivity in the following manner. Connect a 1,500 Ω 10W resistor paralleled by a 0.15 μ F AC-type capacitor between an exposed metal part and a known good earth ground. Measure the AC voltage across the resistor with the AC voltmeter.

Move the resistor connection to each exposed metal part, particularly any exposed metal part having a return path to the chassis, and measure the AC voltage across the resistor. Now, reverse plug in the AC outlet and repeat each measurement. Voltage measured any must not exceed 0.75 V AC (r.m.s.). This corresponds to 0.5 mA AC (r.m.s.).

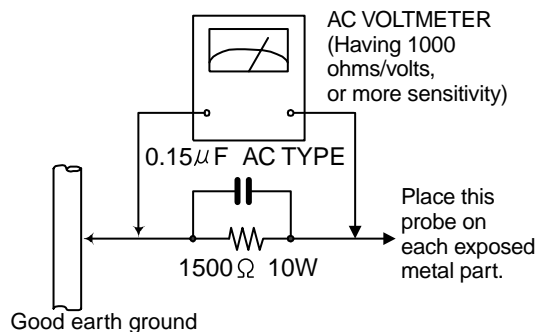

Warning

1. This equipment has been designed and manufactured to meet international safety standards.
2. It is the legal responsibility of the repairer to ensure that these safety standards are maintained.
3. Repairs must be made in accordance with the relevant safety standards.
4. It is essential that safety critical components are replaced by approved parts.
5. If mains voltage selector is provided, check setting for local voltage.

CAUTION

Burrs formed during molding may be left over on some parts of the chassis. Therefore, pay attention to such burrs in the case of preforming repair of this system.

In regard with component parts appearing on the silk-screen printed side (parts side) of the PWB diagrams, the parts that are printed over with black such as the resistor (\blacksquare), diode (\blacksquare) and ICP (\bullet) or identified by the " \triangle " mark nearby are critical for safety.

(This regulation does not correspond to J and C version.)

Preventing static electricity

1. Grounding to prevent damage by static electricity

Electrostatic discharge (ESD), which occurs when static electricity stored in the body, fabric, etc. is discharged, can destroy the laser diode in the traverse unit (optical pickup). Take care to prevent this when performing repairs.

2. About the earth processing for the destruction prevention by static electricity

In the equipment which uses optical pick-up (laser diode), optical pick-up is destroyed by the static electricity of the work environment.

Be careful to use proper grounding in the area where repairs are being performed.

2-1 Ground the workbench

Ground the workbench by laying conductive material (such as a conductive sheet) or an iron plate over it before placing the traverse unit (optical pickup) on it.

2-2 Ground yourself

Use an anti-static wrist strap to release any static electricity built up in your body.

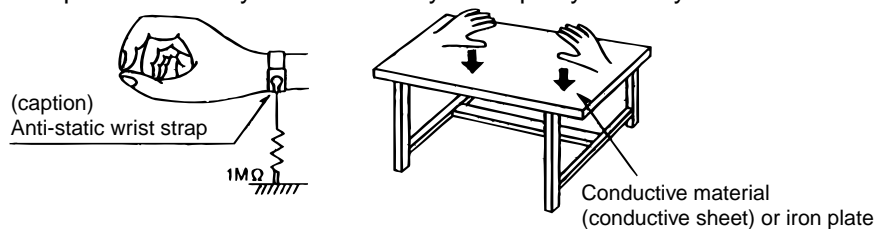

3. Handling the optical pickup

1. In order to maintain quality during transport and before installation, both sides of the laser diode on the replacement optical pickup are shorted. After replacement, return the shorted parts to their original condition. (Refer to the text.)

2. Do not use a tester to check the condition of the laser diode in the optical pickup. The tester's internal power source can easily destroy the laser diode.

4. Handling the traverse unit (optical pickup)

1. Do not subject the traverse unit (optical pickup) to strong shocks, as it is a sensitive, complex unit.

2. Cut off the shorted part of the flexible cable using nippers, etc. after replacing the optical pickup. For specific details, refer to the replacement procedure in the text. Remove the anti-static pin when replacing the traverse unit. Be careful not to take too long a time when attaching it to the connector.

3. Handle the flexible cable carefully as it may break when subjected to strong force.

4. It is not possible to adjust the semi-fixed resistor that adjusts the laser power. Do not turn it.

Precautions for service

Handling of Traverse Unit and Laser Pickup

1. Do not touch any peripheral element of the pickup or the actuator.
2. The traverse unit and the pickup are precision devices and therefore must not be subjected to strong shock.
3. Do not use a tester to examine the laser diode. (The diode can easily be destroyed by the internal power supply of the tester.)
4. When replacing the pickup, after mounting a new pickup, remove the solder on the short land which is provided at the center of the flexible wire to open the circuit.
5. Half-fixed resistors for laser power adjustment are adjusted in pairs at shipment to match the characteristics of the optical block.
Do not change the setting of these half-fixed resistors for laser power adjustment.

Destruction of Traverse Unit and Laser Pickup by Static Electricity

Laser diodes are easily destroyed by static electricity charged on clothing or the human body. Before repairing peripheral elements of the traverse unit or pickup, be sure to take the following electrostatic protection:

1. Wear an antistatic wrist wrap.
2. With a conductive sheet or a steel plate on the workbench on which the traverse unit or the pick up is to be repaired, ground the sheet or the plate.

When you remove the traverse mechanism from the servo control substrate

The laser diode of pick-up might be destroyed by static electricity and set switch (S11) on the pick-up board on "SHORT" side, please before removing the card wire from connector (CN10). Moreover, please set switch (S11) on "OPEN" side after assembling and inserting the card wire in connector (CN10) without fail at times.

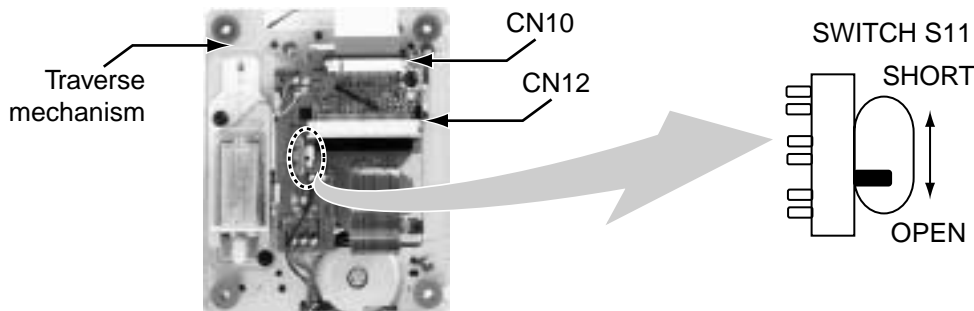

When you remove the pick-up from the traverse mechanism

The laser diode of the pick-up might be destroyed by static electricity. Before extracting the flexible wire from connector (CN12), please solder point **A** as shown below. Moreover, please remove solder in point **A** after inserting a flexible wire in connector (CN12).

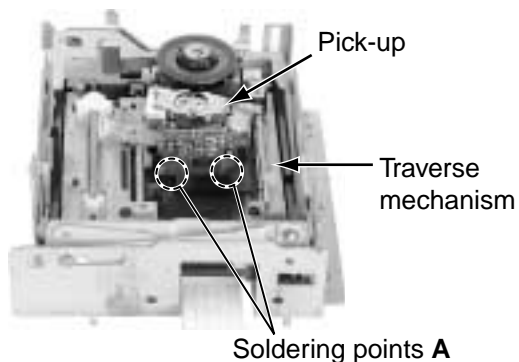

Important for laser products

1. CLASS 1 LASER PRODUCT

2. DANGER : Invisible laser radiation when open and interlock failed or defeated. Avoid direct exposure to beam.

3. CAUTION : There are no serviceable parts inside the Laser Unit. Do not disassemble the Laser Unit. Replace the complete Laser Unit if it malfunctions.

4. CAUTION : The compact disc player uses invisible laser radiation and is equipped with safety switches which prevent emission of radiation when the drawer is open and the safety interlocks have failed or are defeated. It is dangerous to defeat the safety switches.

5. CAUTION : If safety switches malfunction, the laser is able to function.

6. CAUTION : Use of controls, adjustments or performance of procedures other than those specified herein may result in hazardous radiation exposure.

⚠ CAUTION Please use enough caution not to see the beam directly or touch it in case of an adjustment or operation check.

VARNING : Osynlig laserstrålning är denna del är öppnad och spårren är urkopplad. Betrakta ej strålen.

VARO : Avattaessa ja suojalukitus ohitettaessa olet alttiina näkymättömälle lasersäteilylle. Älä katso säteeseen.

ADVARSEL : Usynlig laserstrålning ved åbning , når sikkerhedsafbrydere er ude af funktion. Undgå udsættelse for stråling.

ADVARSEL : Usynlig laserstrålning ved åbning, når sikkerhedsbryteren er avslott. unngå utsettelse for stråling.

REPRODUCTION AND POSITION OF LABELS

CLASS 1
LASER PRODUCT



WARNING LABEL

| | |
|--|--|
| DANGER : Invisible laser radiation when open and interlock or defeated. AVOID DIRECT EXPOSURE TO BEAM (e) | VARNING : Osynlig laserstrålning är denna del är öppnad och spårren är urkopplad. Betrakta ej strålen. (s) |
| VARO : Avattaessa ja suojalukitus ohitettaessa olet alttiina näkymättömälle lasersäteilylle. Älä katso säteeseen. (d) | ADVARSEL : Usynlig laserstrålning ved åbning , når sikkerhedsafbrydere er ude af funktion. Undgå udsættelse for stråling. (f) |



Disassembly method

<Main body>

■ Removing the metal cover

(See Fig.1 to 3)

1. Remove the six screws marked **A** on the back of the body.
2. Remove the two screws marked **B** on both sides of the body.
3. Remove the metal cover from the body by lifting the rear part of the cover.

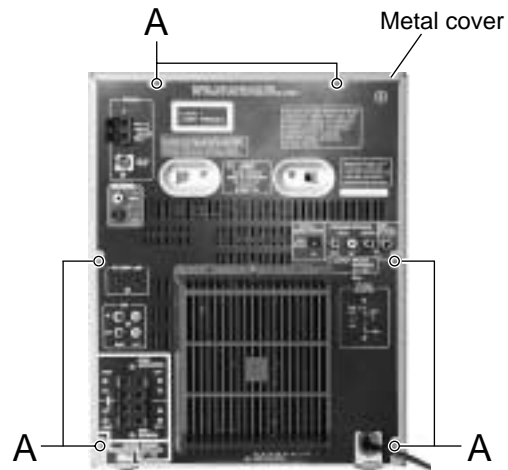

Fig.1

CAUTION: Do not break the front panel tab fitted to the metal cover.

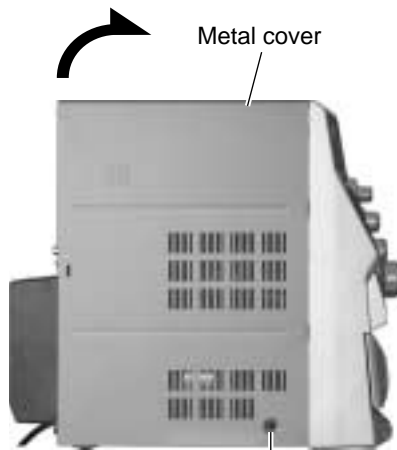

Fig.3

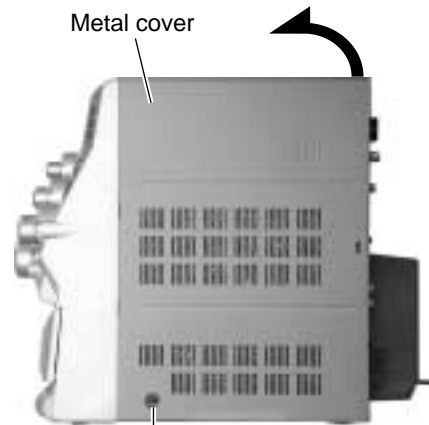

Fig.2

■ Removing the tuner board

(See Fig.4)

- Prior to performing the following procedures, remove the metal cover.
1. Disconnect the card wire from connector CN1 on the tuner board.
 2. Remove the plastic rivet fixing the tuner board.
 3. Remove the two screws marked **C** on the back of the body.

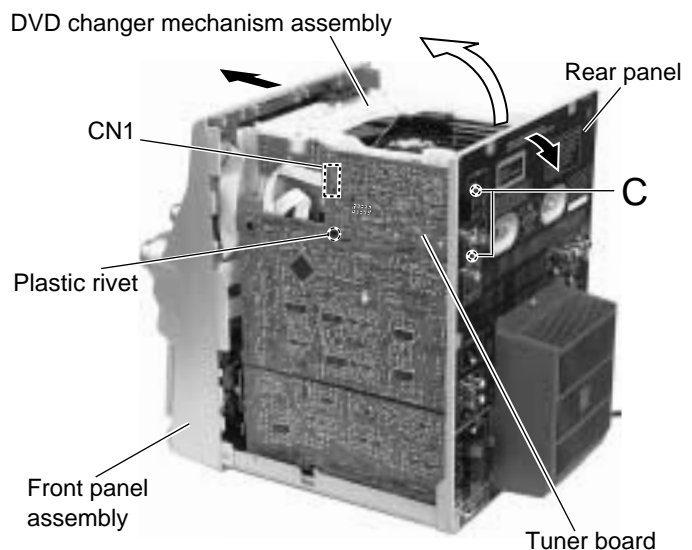

Fig.4

■ Removing the DVD changer mechanism assembly (See Fig.5 to 6)

- Prior to performing the following procedures, remove the metal cover and the tuner board.

1. Disconnect the card wire from the connectors CN540, CN541 and CN542 on the main board.
2. Remove the two screws marked **D** on the upper side of the body and two screws marked **F** on the back of rear panel.
3. Remove the plastic rivet attaching the main board.
4. Pull both the rear panel and the front panel assembly to the outside, then remove the DVD changer mechanism assembly by lifting the rear part of the assembly.

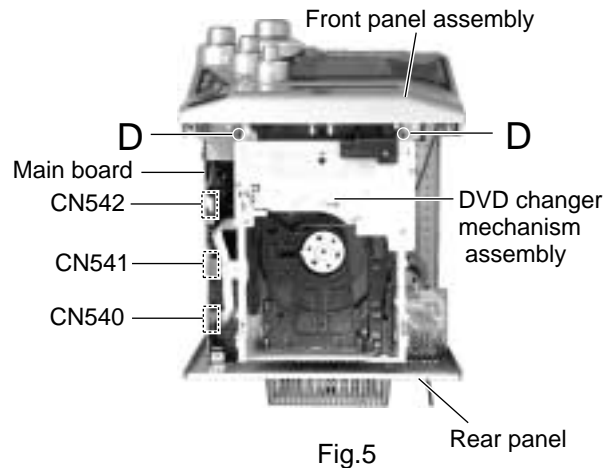

Fig.5

CAUTION: To prevent damage to the DVD fitting, be sure to pull both the rear panel and the front panel assembly enough to remove the DVD changer mechanism assembly.

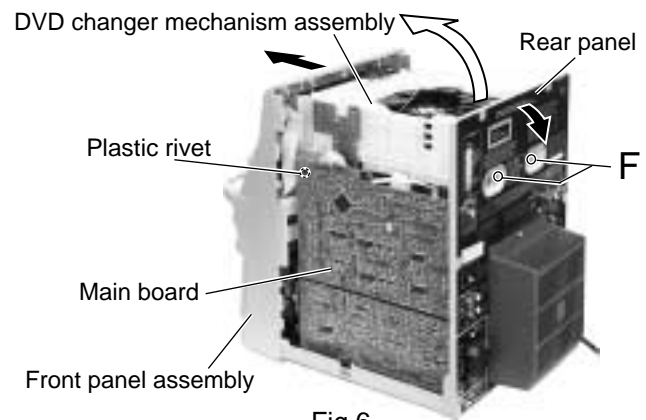
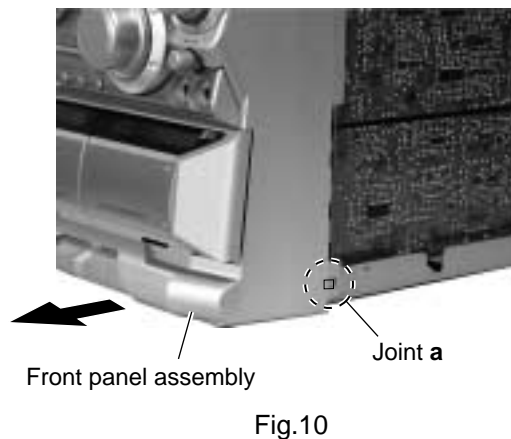
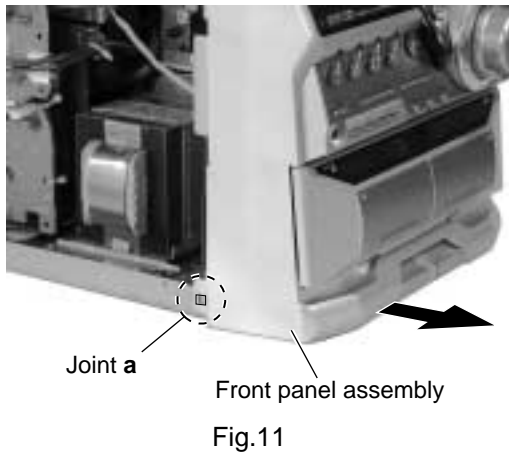
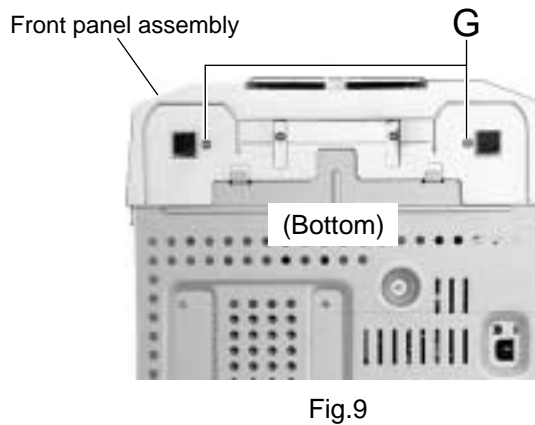
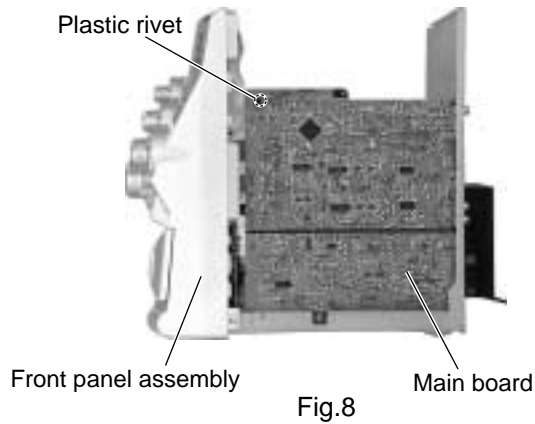
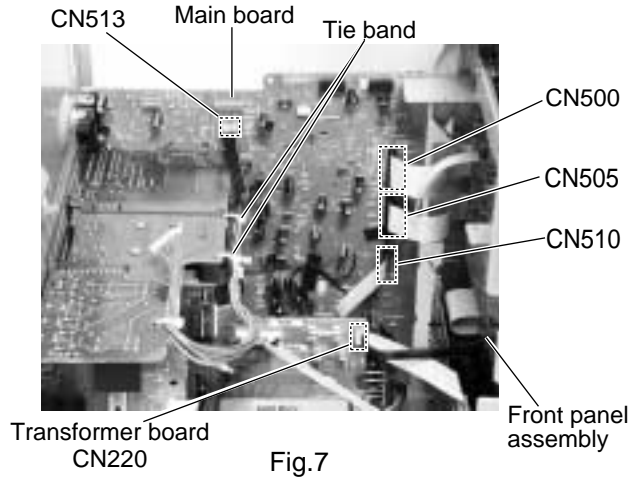

Fig.6

■ **Removing the front panel assembly**
(See Fig.7 to 11)

• Prior to performing the following procedures, remove the metal cover, the tuner board and the DVD changer mechanism assembly.

1. Remove the plastic rivet attaching the main board.
2. Disconnect the card wires from the connector CN500, CN505 and CN510 on the main board respectively.
3. Remove the tie band and disconnect the wire from the connector CN513 on the main board.
4. Disconnect the wire from the connector CN220 on the transformer board.
5. Remove the two screws marked **G** on the bottom of the body.
6. Release the two joints marked **a** on the lower right and left sides of the body using a screwdriver, and remove the front panel assembly toward the front.



■ Removing the rear cover / rear panel (See Fig.12 to 15)

· Prior to performing the following procedures, remove the metal cover, the tuner board and the DVD changer mechanism assembly.

1. Remove the screw marked **H** attaching the rear cover on the back of the body.
2. Push each tab of the four joints marked **b** in the direction of the arrow and release.
3. Remove the seventeen screws marked **I** attaching the rear panel.
4. Release the joints marked **c** on each lower side of the rear panel using a screwdriver and remove the rear panel backward.

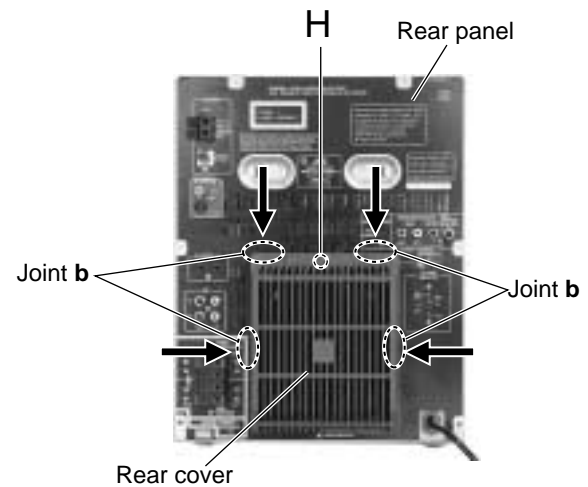

Fig.12

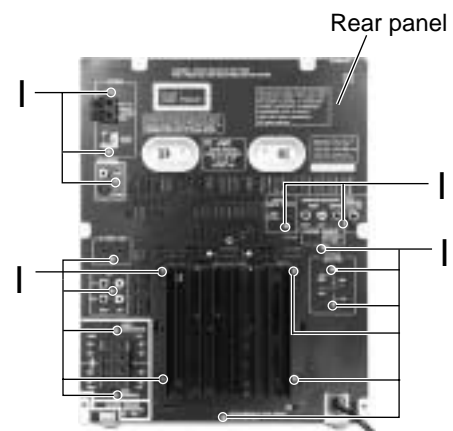

Fig.13

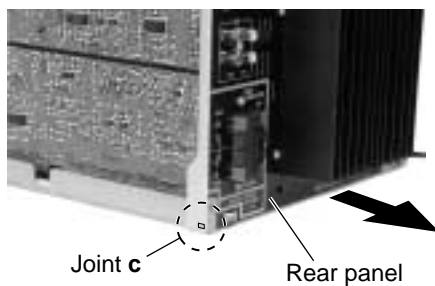

Fig.15

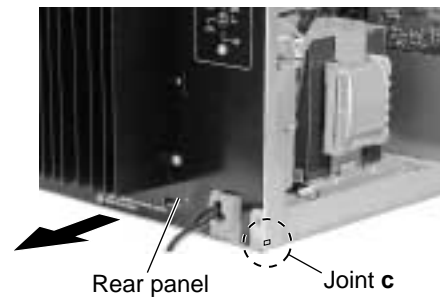

Fig.14

■ Removing the power cord (See Fig.16)

· Prior to performing the following procedures, remove the metal cover, the tuner board the DVD changer mechanism assembly and rear panel.

1. Move the power cord stopper upward and pull out it from the base chassis.
2. Disconnect the power cord from connector CN250 on the power supply board.
3. Remove the tie band from the power supply board.

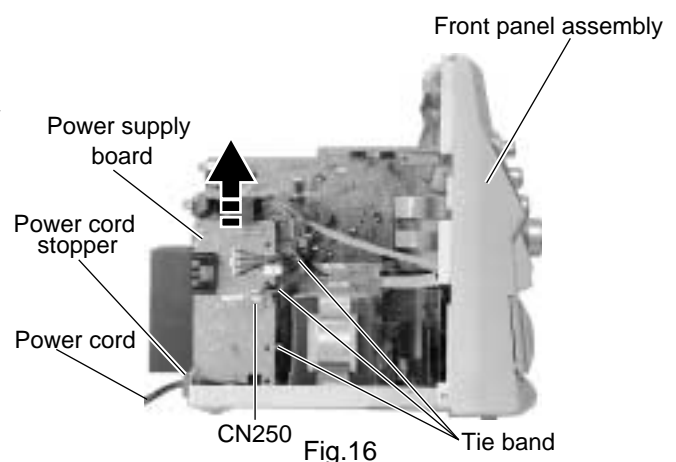
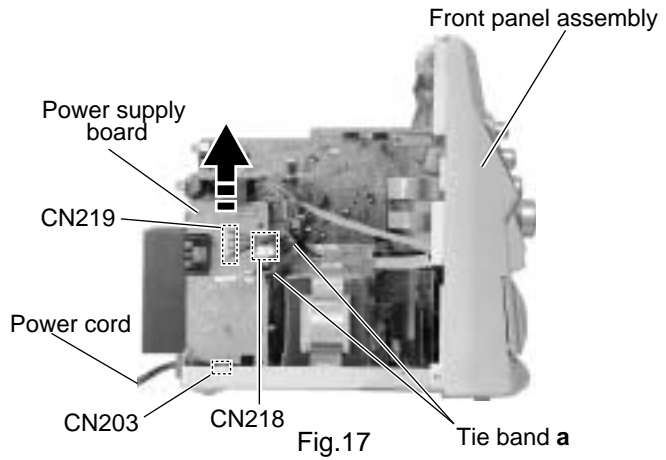

Fig.16

■ Removing the power supply board
(See Fig.17)

- Prior to performing the following procedures, remove the metal cover, the tuner board, the DVD changer mechanism assembly, the rear panel and the power cord.
1. Remove the tie band marked **a** attaching the power supply board.
 2. Disconnect the connector CN218 and CN219 on the power supply board.
 3. Disconnect the connector CN203 on the power supply board from the regulator board.



■ Removing the amplifier board (1, 2), AV output board & speaker terminal board
(See Fig.18 to 21)

- Prior to performing the following procedures, remove the metal cover, the tuner board, the DVD changer mechanism assembly, the power supply board and the rear panel.
1. Remove the tie band marked **b** attaching the wire to the AV output board.
 2. Disconnect the card wire from the connector CN513 on the main board.
 3. Disconnect the connector CN521 on the main board.
 4. Disconnect the card wire from the connector CN703 on the amplifier board (2).
 5. Disconnect the connectors CN205 and CN206 on the amplifier board (1, 2) from the regulator board (The heat sink and heat sink bracket will be detached at once).
 6. Disconnect the connector CN207 on the speaker terminal board from the regulator board.

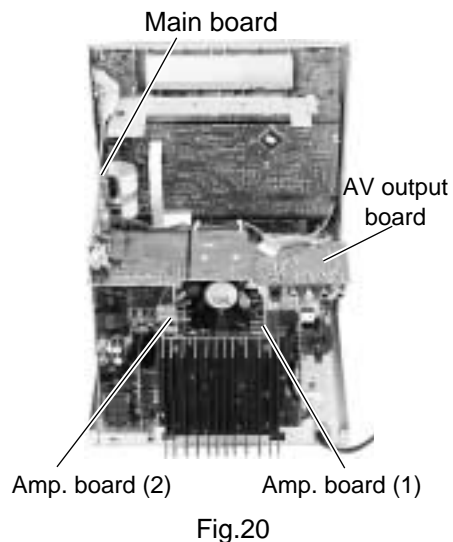
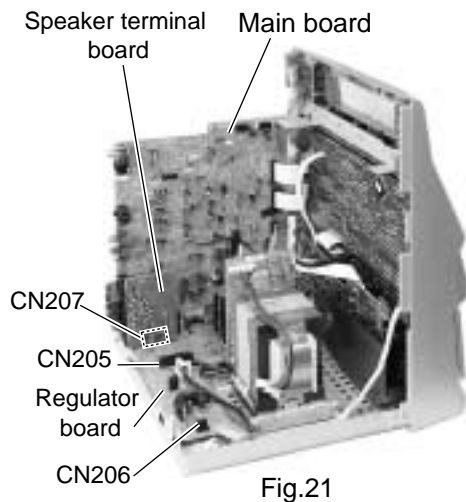
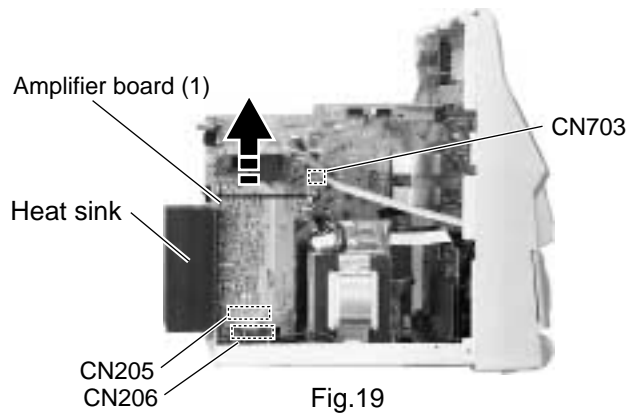
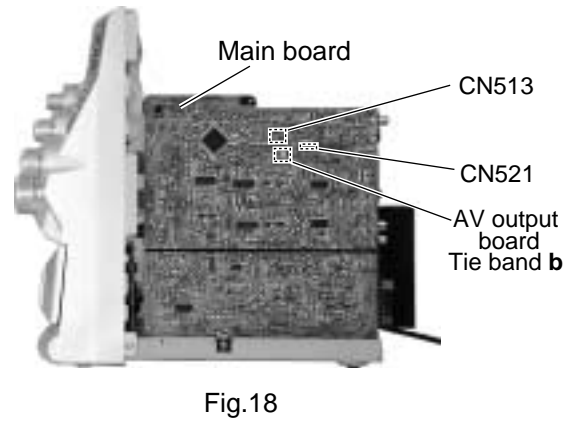

■ Removing the AV output board

(See Fig.22, 23)

- Prior to performing the following procedures, remove the metal cover, the tuner board, the DVD changer mechanism assembly, the rear panel, the amplifier board (1,2) and the power supply board.
1. Disconnect the connector CN705, CN372 and CN373 on the amplifier board (1, 2).
 2. Remove the two screws marked **J** attaching the AV output board to the fan bracket.
 3. Pull out the fan bracket from the AV output board.

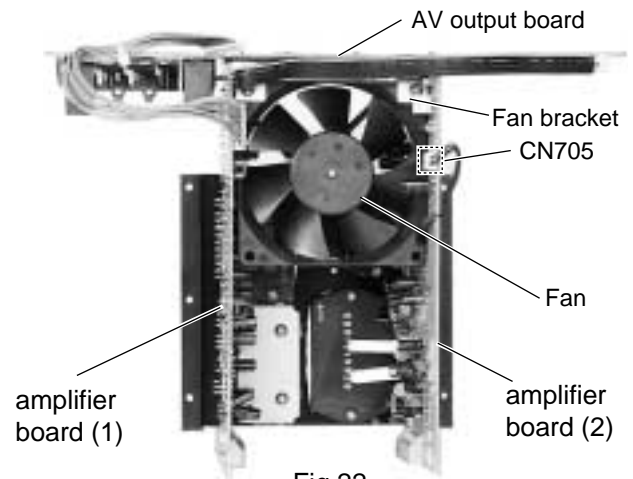

Fig.22

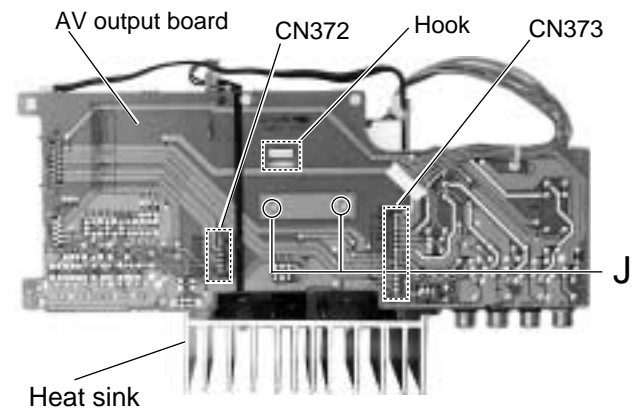

Fig.23

■ Removing the Heat sink

(See Fig.24)

- Prior to performing the following procedures, remove the metal cover, the tuner board, the power supply board, the DVD changer mechanism, assembly the rear panel, the tuner board, the amplifier board (1,2) and AV output board.
1. Remove the eight screws marked **K** attaching the ICs on the heat sink.

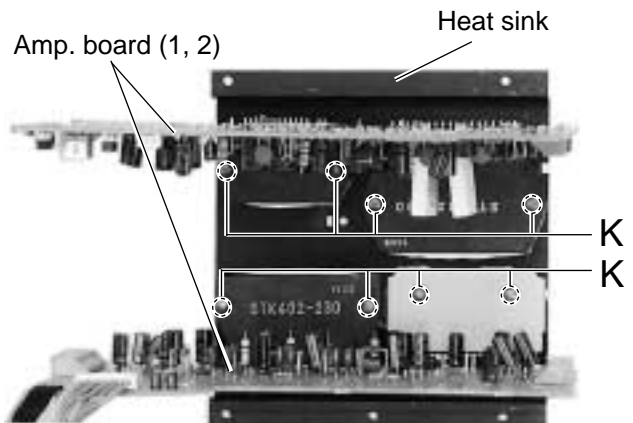

Fig.24

■ Removing the ICs

(See Fig.25)

- Prior to performing the following procedures, remove the metal cover, the tuner board, the DVD changer mechanism assembly, the rear panel, the tuner board, the AV output board, the amplifier board (1,2), the power supply board and the heat sink.

1. Unsolder the ICs solder points.
2. Remove the ICs.

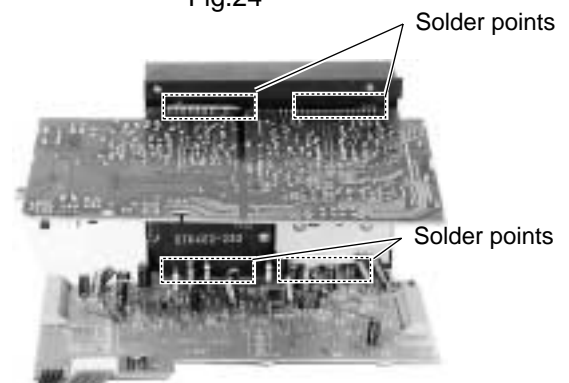

Fig.25

■ Removing the main board

(See Fig.26, 27)

- Prior to performing the following procedures, remove the metal cover, the tuner board, the DVD changer mechanism assembly, the rear panel, the power supply board, the amplifier board and AV output board.
1. Disconnect the card wires from the connector CN500, CN505 and CN510 on the main board.
 2. Disconnect the flat wires from the connector CN220 on the transformer board.
 3. Disconnect the connector CN530 and CN531 on the main board from the regulator board.
 4. Remove the screw marked **L** attaching the main board on the right side of the body.

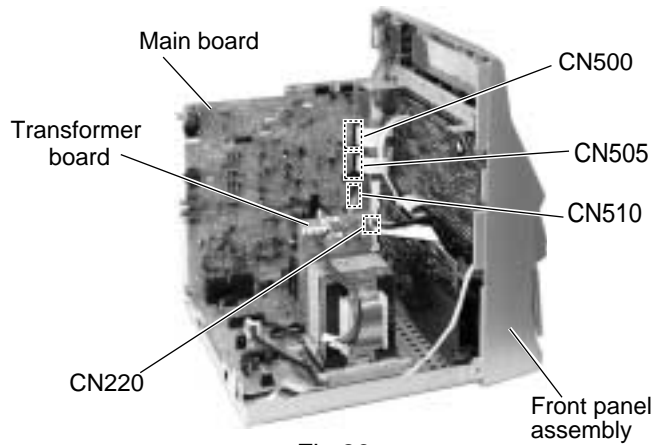

Fig.26

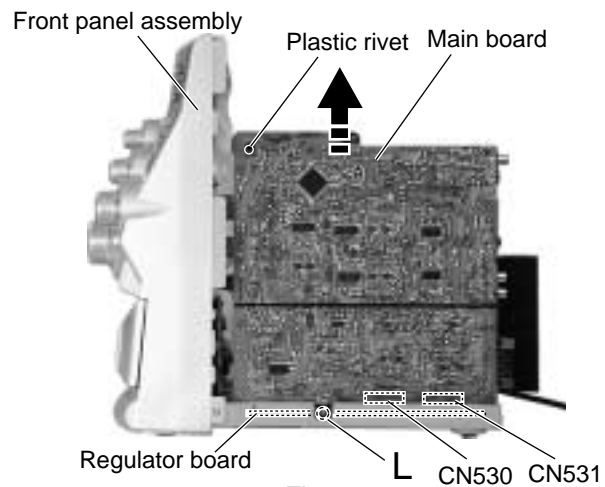

Fig.27

■ Removing the regulator board / power transformer assembly

(See Fig.28)

- Prior to performing the following procedures, remove the metal cover, the tuner board, the DVD changer mechanism assembly, the rear panel, the power supply board, the amplifier board (1, 2), the main board, the speaker terminal board and AV output board.
1. Disconnect the wire from connector CN204 on the regulator board.
 2. Remove the two screws marked **N** attaching the regulator board.
 3. Remove the four screws marked **M** attaching the transformer.

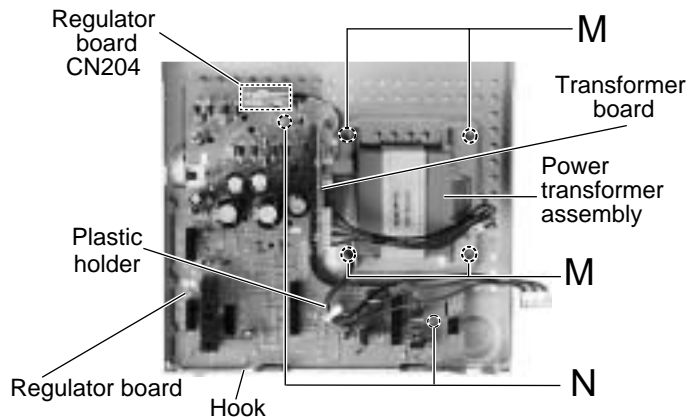

Fig.28

<Front panel assembly>

- Prior to performing the following procedures, remove the metal cover, the DVD changer mechanism assembly and front panel assembly.

■ Removing the cassette mechanism assembly (See Fig.29)

1. Disconnect the card wire from the connector CN306 on the head amplifier & mechanism control board.
2. Remove the seven screws marked **O** attaching the cassette mechanism assembly.

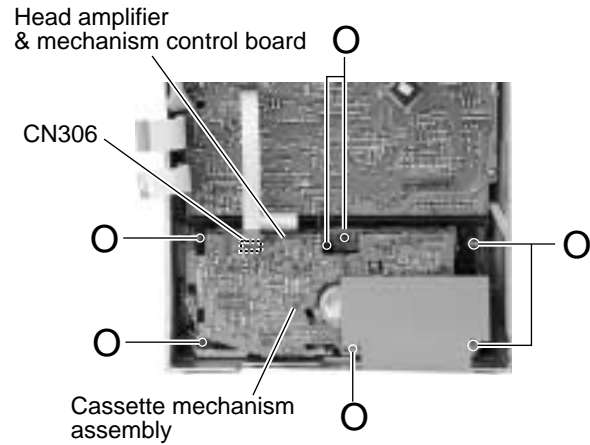

Fig.29

■ Removing the display & system control board (See Fig.30 to 32)

1. Remove the four screws marked **P** attaching the stay bracket.
2. Remove the seven screws marked **Q** attaching the display & system control board.
3. Disconnect the card wires from the connector CN316 and CN881 on the display & system control board.
4. Disconnect the connector CN870 on the display & system control board from the preset / tuning switch board.
5. If necessary, disconnect the wire from the connector CN870 on the front side of the display & system control board and unsolder FW915.

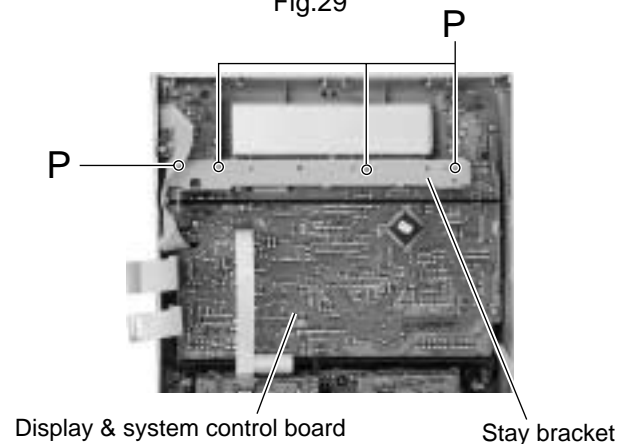

Fig.30

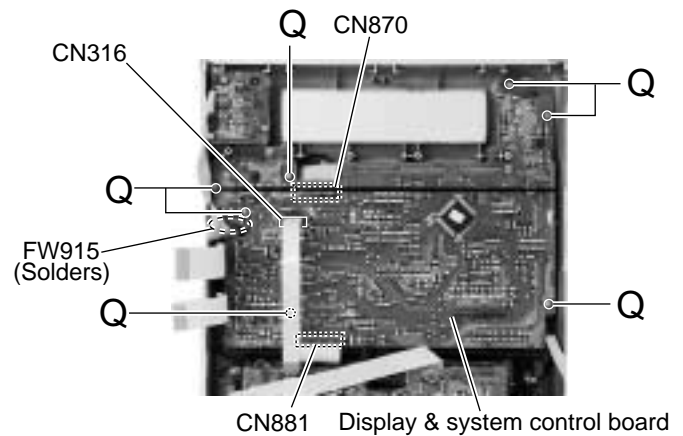

Fig.31

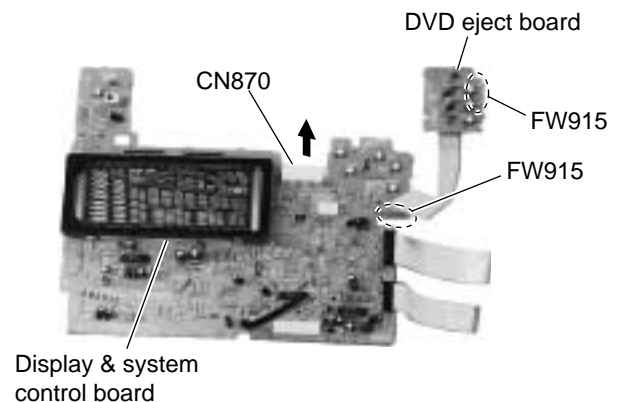

Fig.32

**■Removing the DVD eject board
(See Fig.33)**

1. Remove the three screws marked **R** attaching the DVD eject board.
2. If necessary, unsolder FW915 on the DVD eject board.

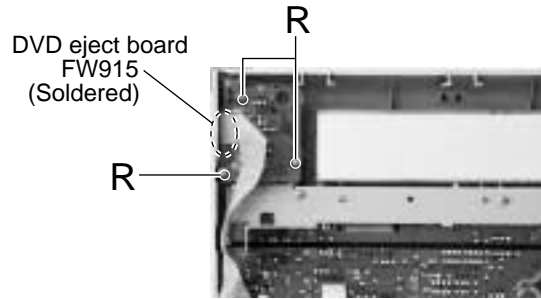

Fig.33

**■Removing the preset / tuning switch board
(See Fig.34, 35)**

• Prior to performing the following procedures, remove the display & system control board.

1. Pull out the PRESET knob on the front panel.
2. Remove the five screws marked **S** attaching the preset / tuning switch board.
3. If necessary, unsolder FW901 on the preset / tuning switch board.

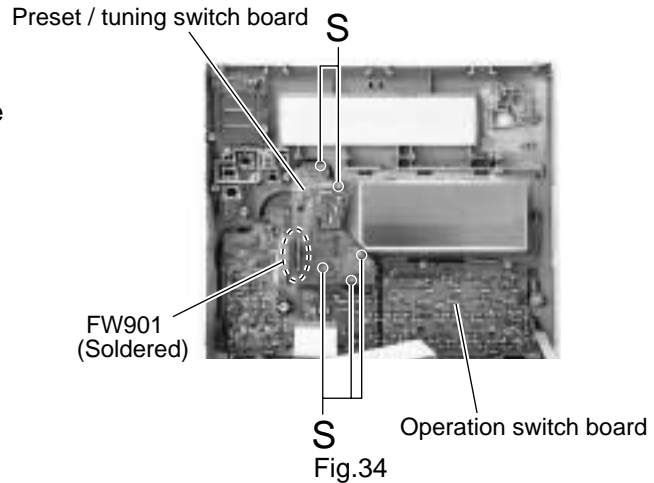

Fig.34

**■Removing the operation switch board
(See Fig.35, 36)**

• Prior to performing the following procedures, remove the display & system control board and the preset / tuning switch board.

1. Pull out the volume knob on the front panel and remove the nut. Pull out the SOUND MODE knob and the SUBWOOFER level knob toward the front. Pull out the mic level knob toward the front.
2. Remove the twelve screws marked **T** attaching the operation switch board.
3. Release each tab of the seven joints marked **g** retaining the operation switch board.

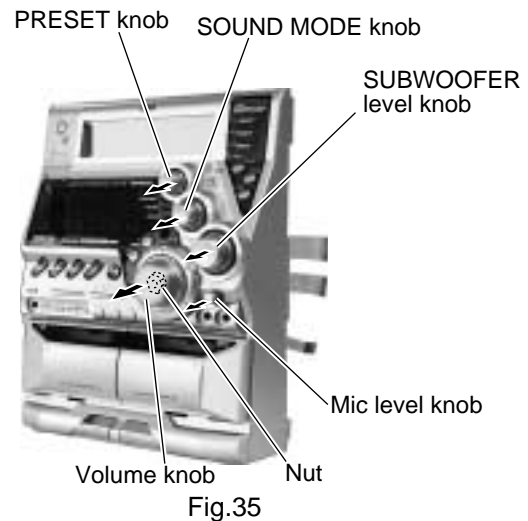

Fig.35

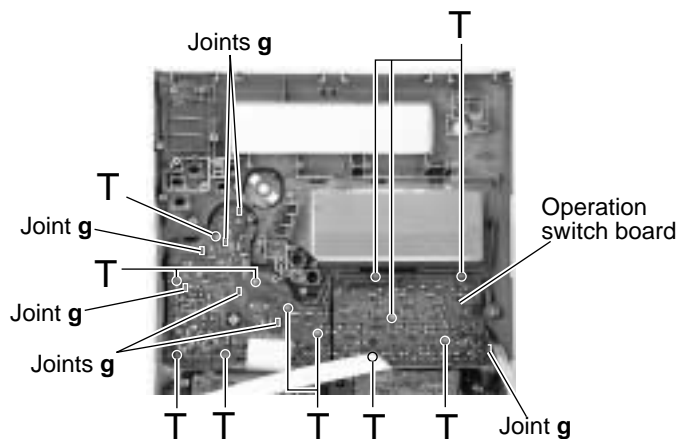

Fig.36

< Main Speaker >

■ Removing the front cover (See Fig.1, 2)

1. Remove the four screws marked **A** on the front of the body.
2. Remove the front cover from the four holders marked **a** that are fixing the front cover.
3. Pull out the front cover toward the front while disengaging the four joints marked **a**.

Note: Because it is difficult to take away the cover, insert a minus driver, etc. in the place between the main body and the front cover as shown in Fig.1 before removing the front cover. Exercise care not to damage the main body and the front cover when inserting the minus driver. For this purpose, insert the minus driver together with cloth and the like.

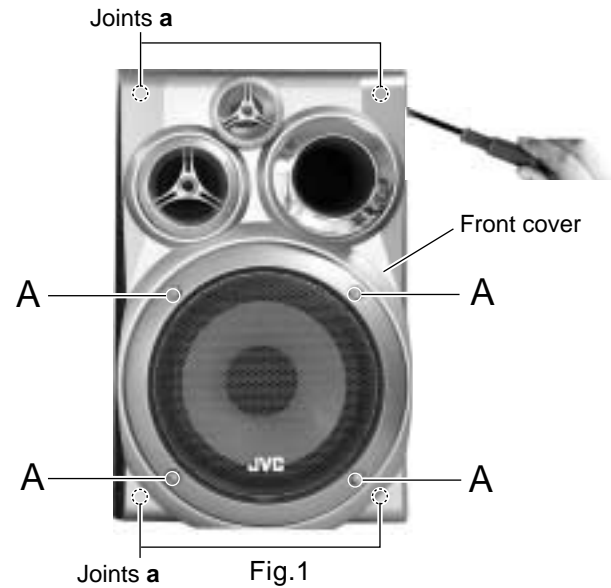

■ Removing the squawker (See Fig.2)

- Prior to performing the following procedures, remove the front cover.
1. Remove the two screws marked **B** on the front cover.
 2. Disconnect the yellow and black wires from the speaker terminals on the squawker.

■ Removing the woofer (See Fig.2)

- Prior to performing the following procedures, remove the front cover.
1. Remove the four screws marked **C**.
 2. Remove the woofer and disconnect the yellow and black wires from the speaker terminals.
 3. Remove the squawker and disconnect the yellow and black wires from the speaker terminals.

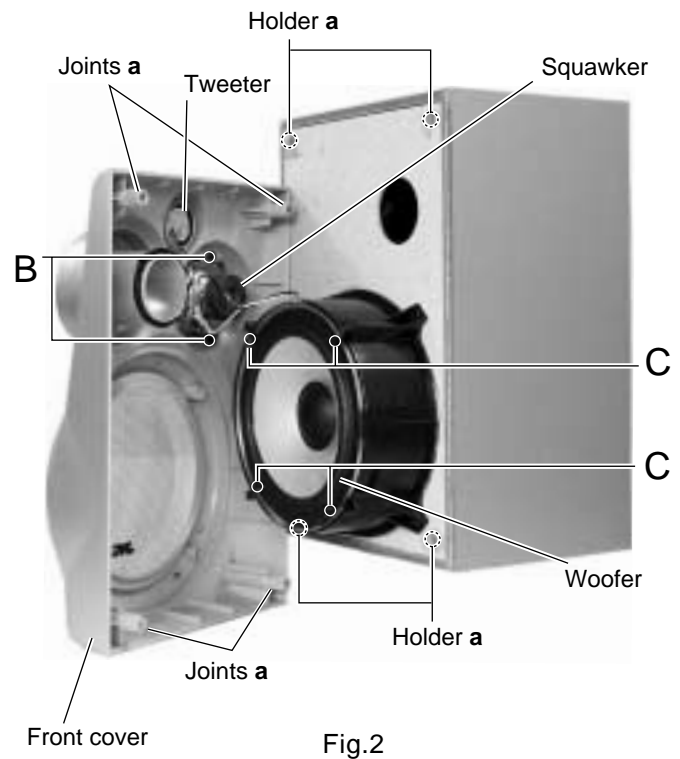

< Subwoofer >

■ Removing the front cover (See Fig.3, 4)

1. Remove the four screws **D** on the front of the body.
2. Remove the front cover from the four holders marked **b** that are fixing the front cover.
3. Pull out the front cover toward the front while disengaging the four joints marked **b**.

Note: Because it is difficult to take away the cover, insert a minus driver, etc. in the place between the main body and the front cover as shown in Fig.1 before removing the front cover. Exercise care not to damage the main body and the front cover when inserting the minus driver. For this purpose, insert the minus driver together with cloth and the like.

■ Removing the subwoofer (See Fig.4)

- Prior to performing the following procedures, remove the front cover.

1. Remove the four screws marked **E** on the front of the body.
2. Pull out the subwoofer speaker toward the front and disconnect the wire (red and black) from the speaker terminals.

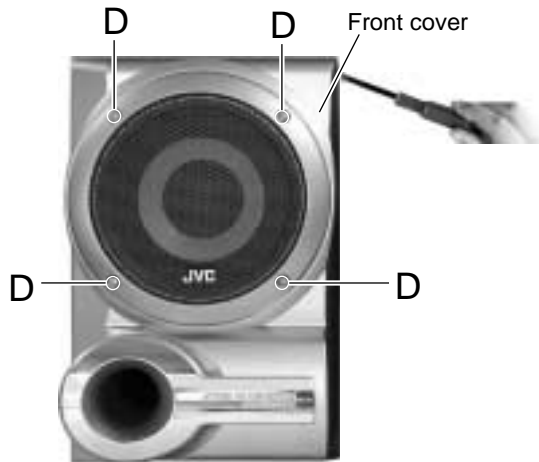

Fig.3

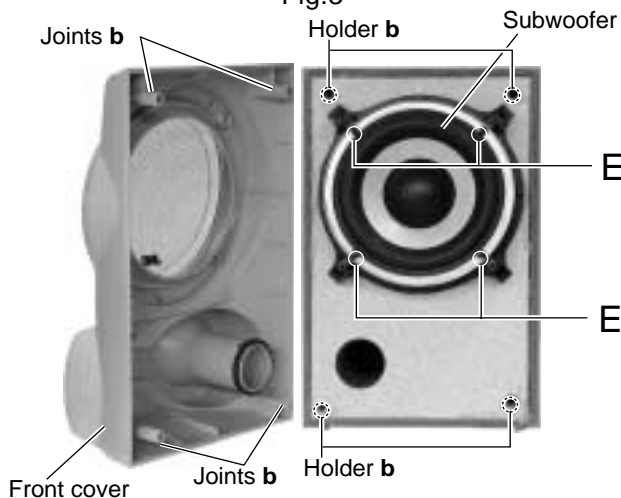

Fig.4

< Center speaker >

■ Removing the front net (See Fig.5, 6)

1. Remove the front net from the four holders marked **c** that are fixing the front net.
2. Pull out the front net toward the front while disengaging the four joints marked **c**.

Note: When it is hard to remove the front net, insert a minus driver, etc. in the place between the front net and the front cover as shown in Fig.5 before removing the front cover. Exercise care not to damage the main body and the front cover when inserting the minus driver. For this purpose, insert the minus driver together with cloth and the like.

■ Removing the center speaker (See Fig.6)

1. Remove the four screws marked **F** on the front of the body.
2. Pull out the center speaker toward the front and disconnect the wire (black and black with white line) from the speaker terminals.

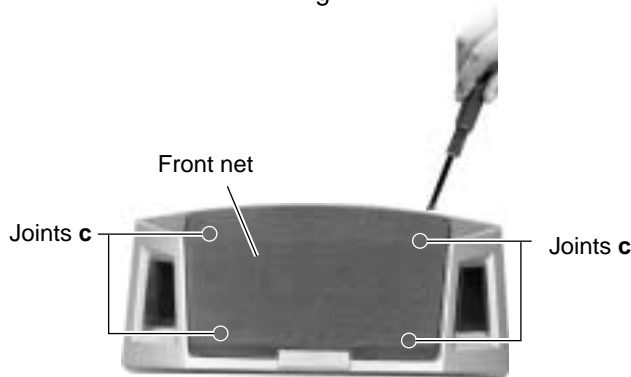

Fig.5

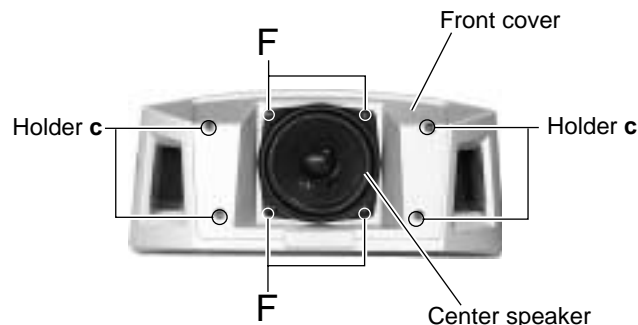

Fig.6

< DVD Changer Mechanism >

■ Removing the DVD Servo control board (See Fig.1)

1. Remove the metal cover.
2. Remove the DVD changer mechanism assembly.
3. From bottom side the DVD changer mechanism assembly, remove the one screw 1 retaining the DVD servo control board.
4. Disconnect the card wire, from the connector CN101, on the DVD servo control board.
5. Disengage the two engagements "A", remove the DVD servo control board.

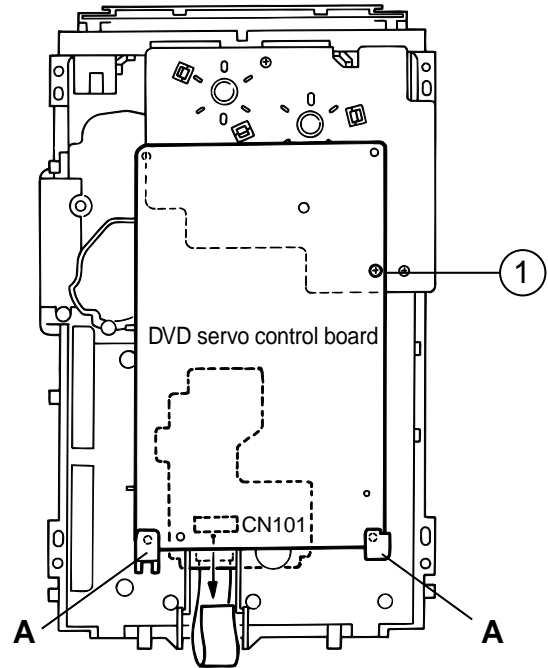

Fig.1

■ Removing the DVD tray assembly (See Fig.2~4)

1. Remove the front panel assembly.
2. Remove the DVD changer mechanism assembly.
3. Remove the DVD servo control board.
4. Remove the screw 2 retaining the disc stopper. (See Fig.3)
5. Remove the three screws 3 retaining the T. bracket. (See Fig.3)
6. From the T. bracket section and clamber base section "B", remove the edges fixing the rod. (See Fig.2)
7. Remove the screw 4 retaining the clamber assembly. (See Fig.3)
8. From the bracket section "C", remove the clamber ass'y. (See Fig.3)
9. From the left side face of the chassis assembly, remove the one screw 5 retaining both of the return spring and lock lever. (See Fig. 4)
10. By removing the pawl at the section "D" fixing the return spring, dismount the return spring. (See Fig.4)
11. Remove the three lock levers. (See Fig.4)

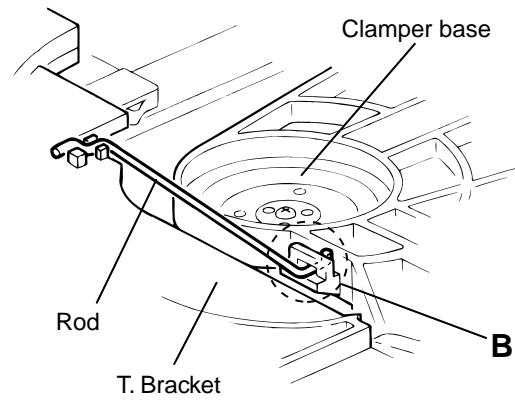

Fig.2

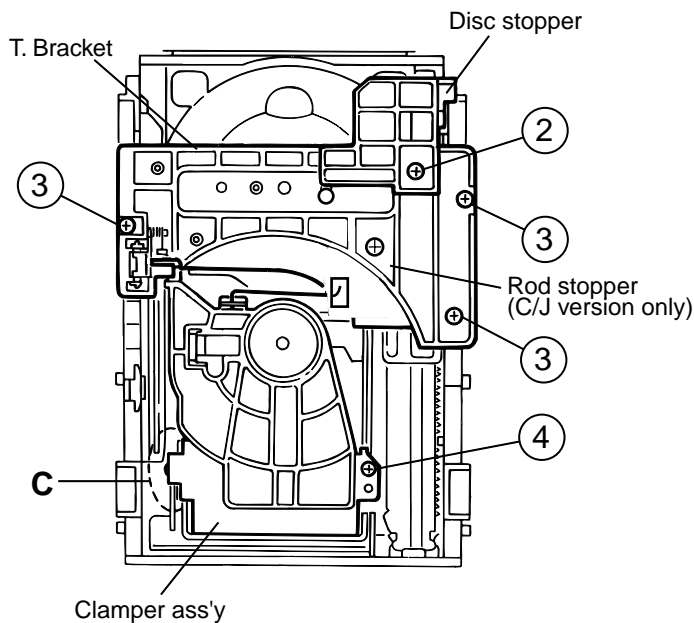

Fig.3

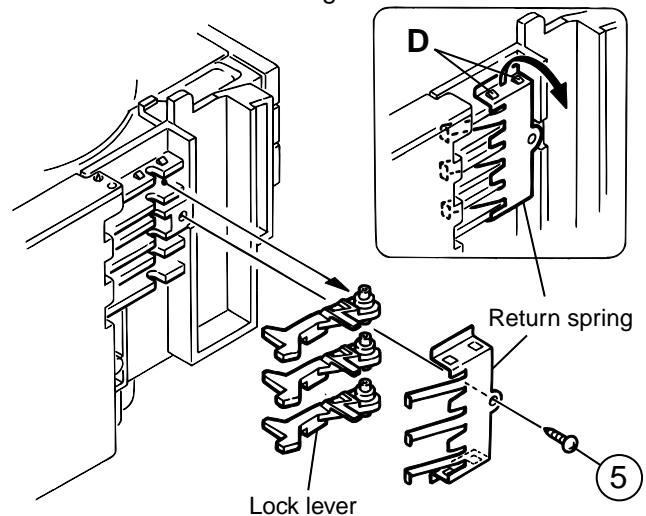

Fig.4

11. Check whether the lifter unit stopper has been caught into the hole at the section "E" of DVD tray assembly as shown in Fig.5.
12. Make sure that the driver unit elevator is positioned as shown in Fig.6 from to the second or fifth hole on the left side face of the DVD Traverse mechanism assembly.

[Caution] In case the driver unit elevator is not at above position, set the elevator to the position as shown in Fig.7 by manually turning the pulley gear as shown in Fig.8.

13. Manually turn the motor pulley in the clockwise direction until the lifter unit stopper is lowered from the section "E" of DVD tray assembly (See Fig.8).
14. Pull out all of the three stages of DVD tray assembly in the arrow direction "F" until these stages stop (See Fig.6).
15. At the position where the DVD tray assembly has stop end, pull out the DVD tray assembly while pressing the two pawls "G and G' " on the back side of DVD tray assembly (See Fig.9). In this case, it is easy to pull out the assembly when it is pulled out first from the stage DVD tray assembly.

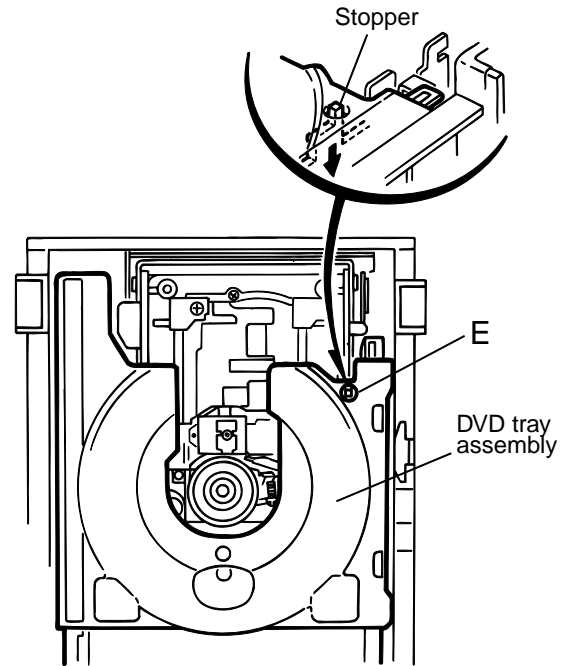

Fig.5

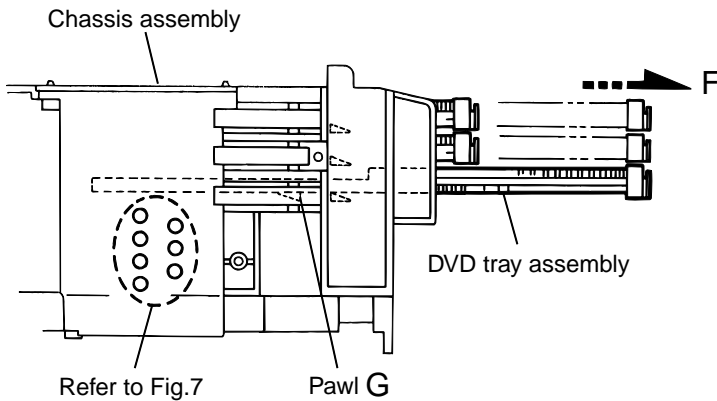

Fig.6

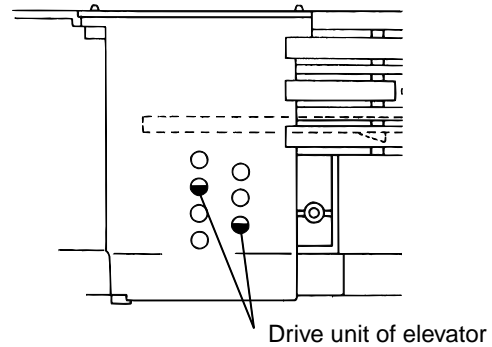

Fig.7

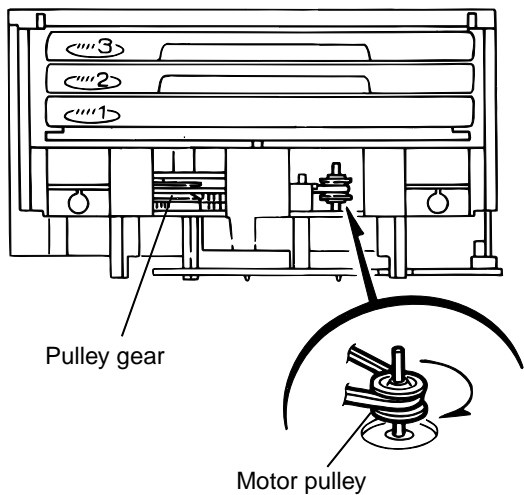

Fig.8

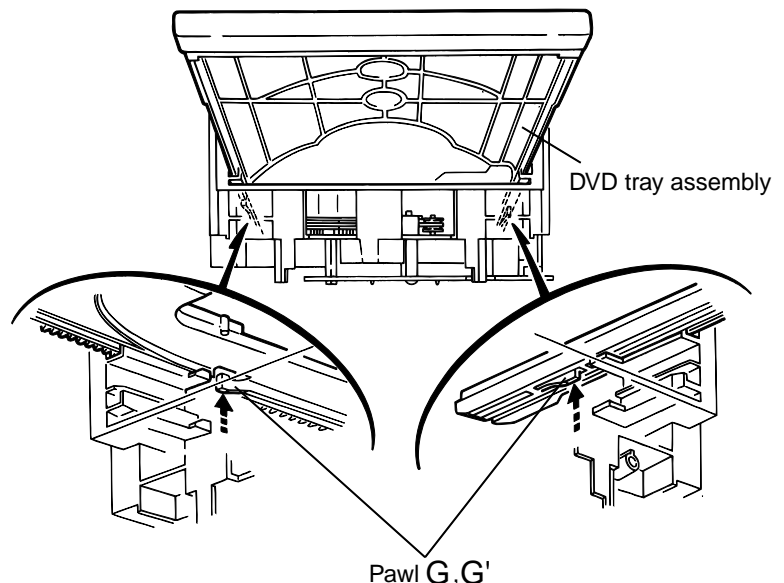

Fig.9

■ Removing the DVD mechanism assembly (See Fig.10)

1. While turning the cams R1 and R2 assembly in the arrow direction "H" , align the shaft "I" of the DVD mechanism assembly to the position shown in Fig.10.
2. Remove the four screw 6 retaining the DVD mechanism assembly.

■ Removing the DVD mechanism (See Fig.11, 12)

1. For dismantling only the DVD mechanism without removing the DVD mechanism assembly, align the shaft "J" of the DVD mechanism assembly to the position shown Fig.11 while turning the cam R1 and R2 assembly in the arrow direction "K" .
2. By raising the DVD mechanism assembly in the arrow direction "L" , remove the assembly from the lifter unit (See Fig.12).

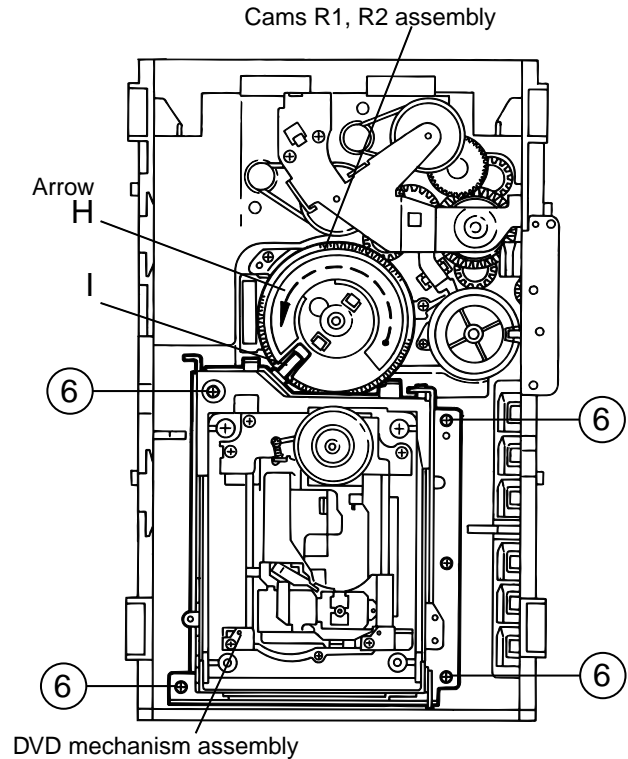

Fig.10

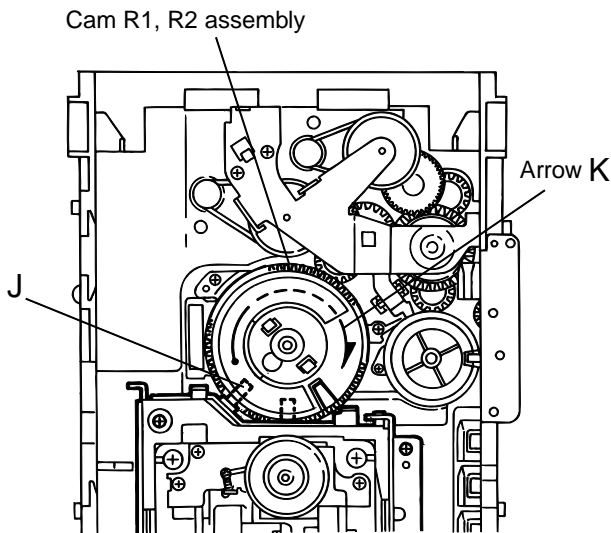

Fig.11

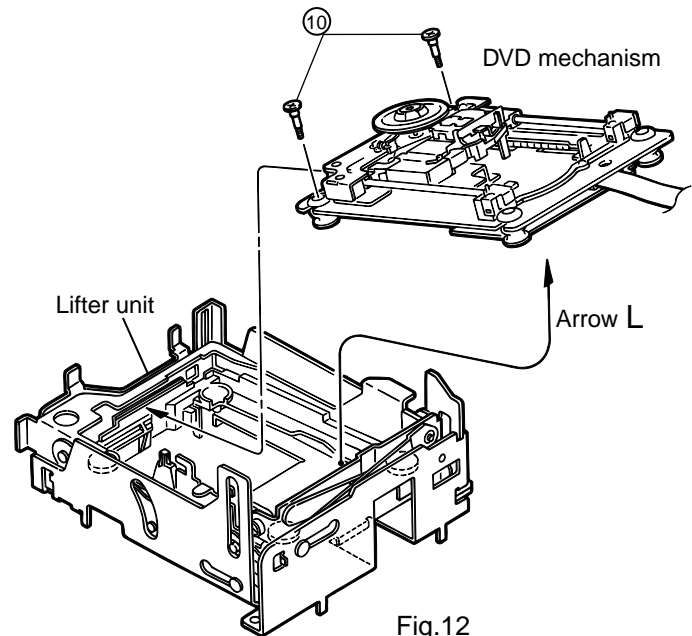

Fig.12

**■ Removing the actuator motor board
(See Fig.14, 15)**

1. Absorb the four soldered positions "M" of the right and left motors with a soldering absorber (See Fig.14).
2. Remove the two screws 7 retaining the actuator motor board (See Fig.14).
3. Remove the two screws 8 retaining the tray select switch board (See Fig.15).

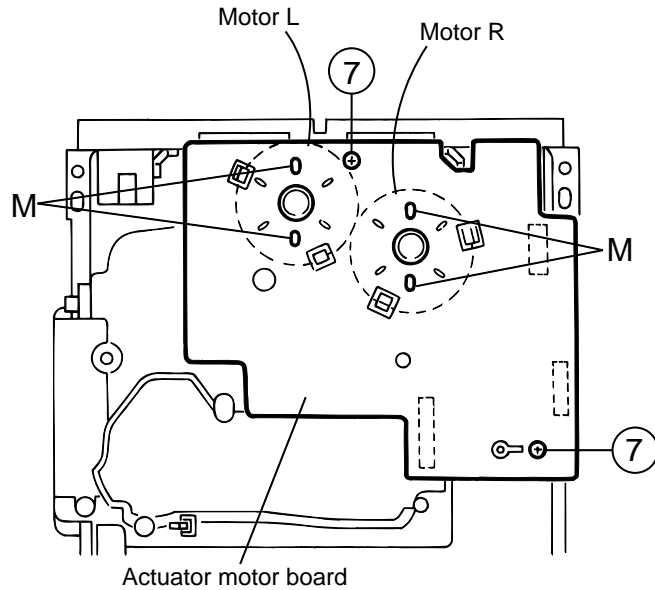

Fig.14

**■ Removing the cam unit
(See Fig.15~18)**

1. Remove the DVD mechanism assembly.
2. While turning the cam gear L, align the pawl "N" position of the drive unit to the notch position (Fig.15) on the cam gear L.
3. Pull out the drive unit and cylinder gear (See Fig.17).
4. While turning the cam gear L, align the pawl "O" position of the select lever to the notch position (Fig.18) on the cam gear L.
5. Remove the four screws 9 retaining the cam unit (cam gear L and cams R1/R2 assembly) (See Fig.18).

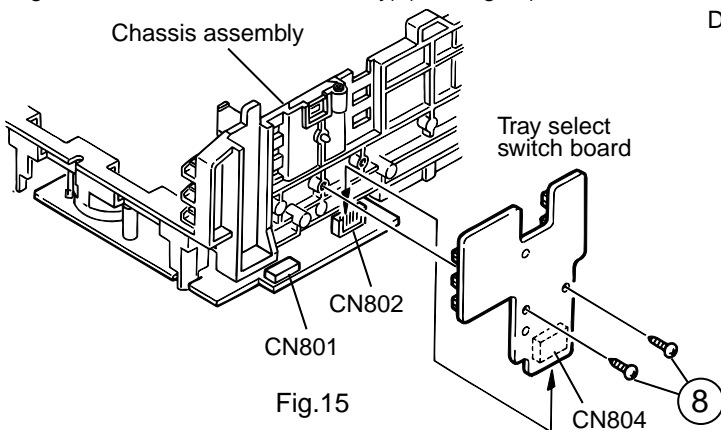

Fig.15

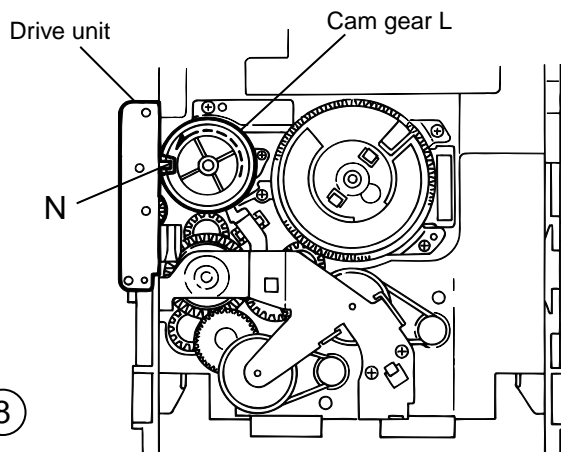

Fig.16

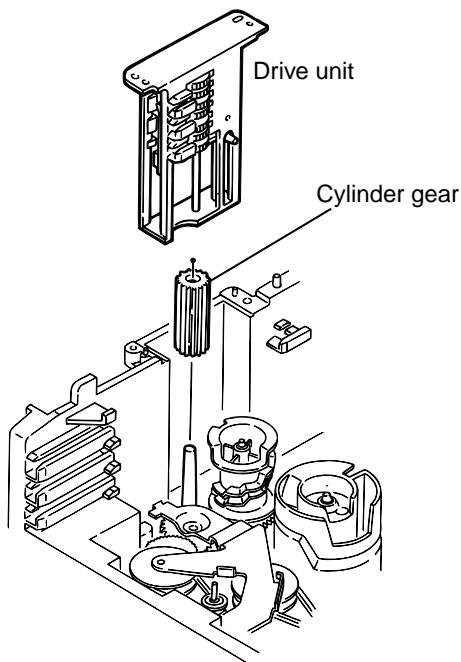

Fig.17

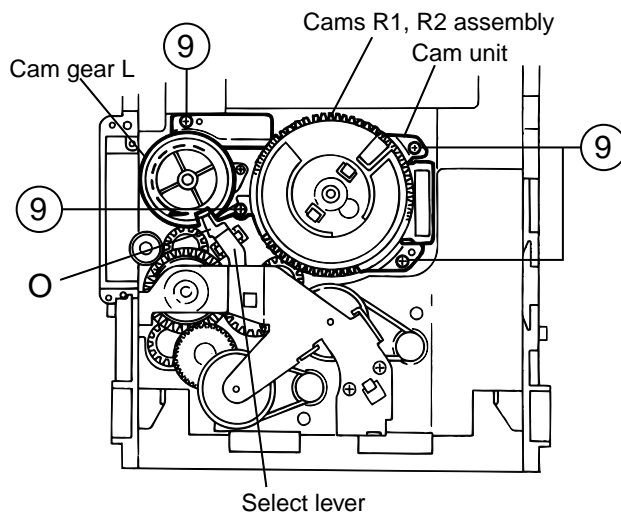

Fig.18

**■ Removing the actuator motor and belt
(See Fig.19~22)**

1. Remove the two screws 10 retaining the gear bracket (See Fig.19).
2. While pressing the pawl "P" fixing the gear bracket in the arrow direction, remove the gear bracket (See Fig.19).
3. From the notch "Q section" on the chassis assembly fixing the edge of gear bracket, remove and take out the gear bracket (See Fig. 20).
4. Remove the belts respectively from the right and left actuator motor pulleys and pulley gears (See Fig. 19).
5. After turning over the chassis assembly, remove the actuator motor while spreading the four pawls "R" fixing the right and left actuator motors in the arrow direction (See Fig. 21).

[Note] When the chassis assembly is turned over under the conditions wherein the gear bracket and belt have been removed, then the pulley gear as well as the gear, etc. constituting the gear unit can possibly be separated to pieces. In such a case, assemble these parts by referring to the assembly and configuration diagram in Fig. 22.

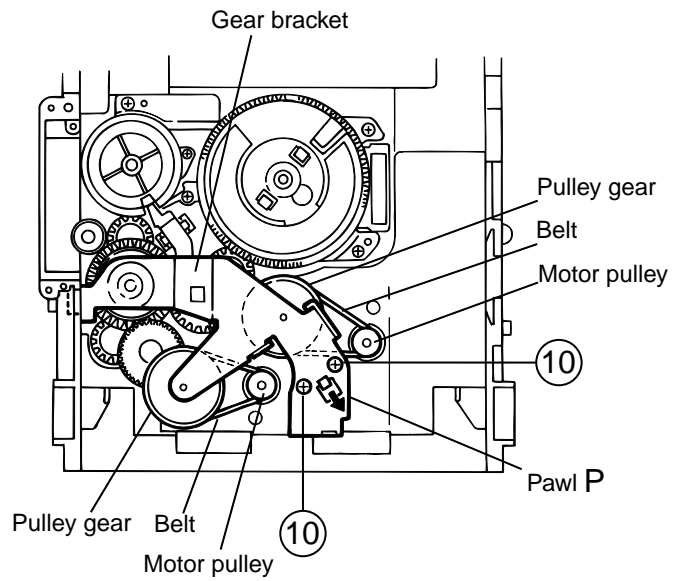

Fig.19

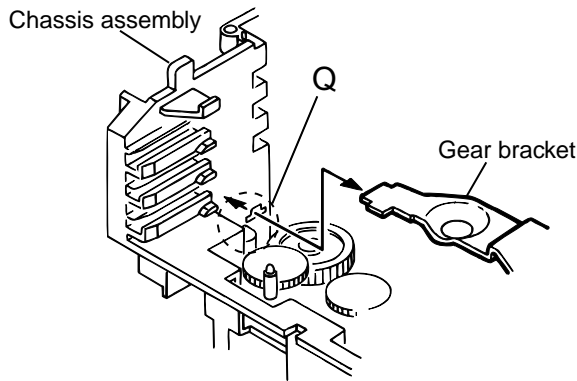

Fig.20

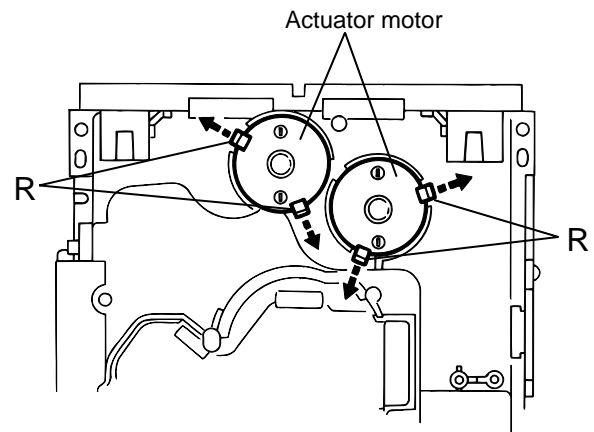

Fig.21

Assembly and Configuration Diagram

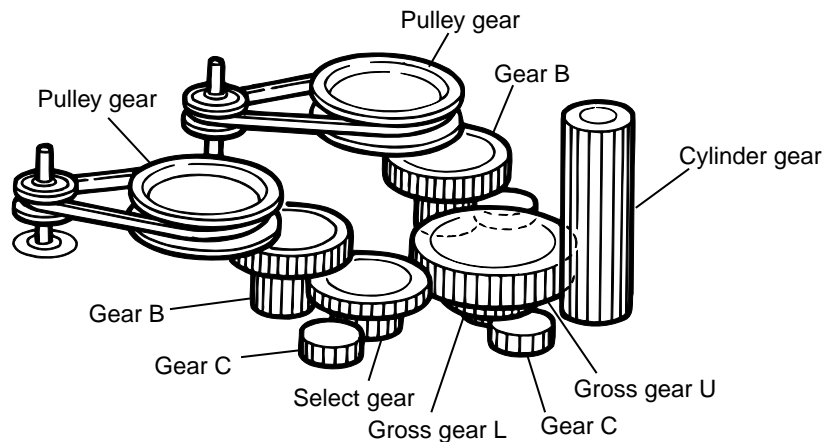

Fig.22

■ Removing the cams R1/R2 assembly and cam gear L (See Fig.23)

1. Remove the slit washer fixing the cams R1 and R2 assembly.
2. By removing the two pawls "S" fixing the cam R1, separate R2 from R1.
3. Remove the slit washer fixing the cam gear L.
4. Pull out the cam gear L from the C.G. base assembly.

■ Removing the C.G. base assembly (See Fig.23, 24)

Remove the three screws 11 retaining the C.G. base assembly.

[Caution] To re-assemble the cylinder gear, etc. with the cam unit (cam gear and cans R1/R2 assembly), gear unit and drive unit, align the position of the pawl "N" on the drive unit to that of the notch on the cam gear L. Then, make sure that the gear unit is engaged by turning the cam gear L (See Fig. 24).

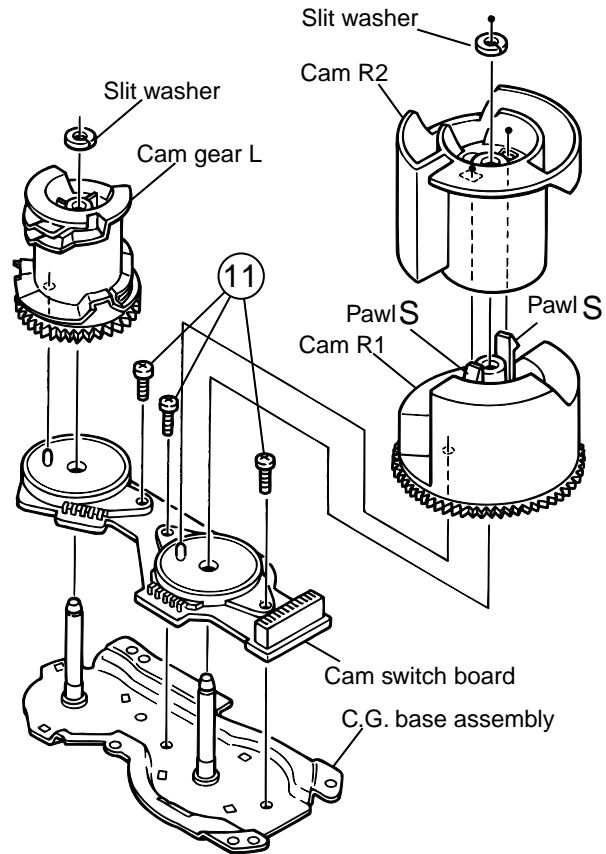

Fig.23

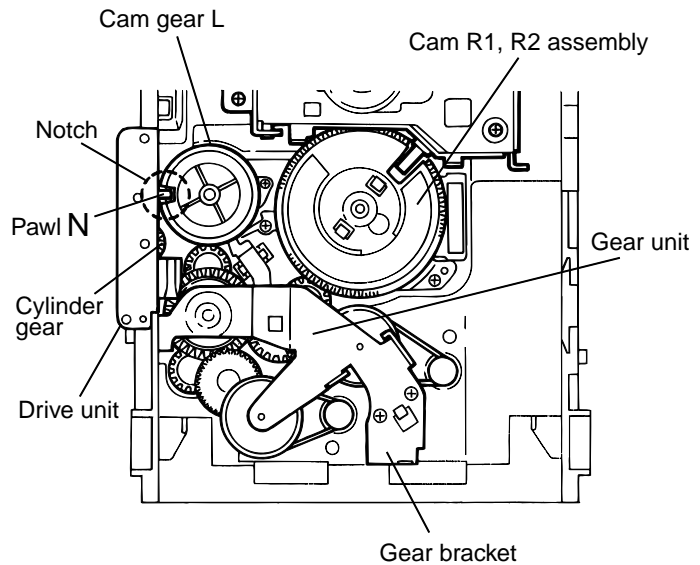

Fig.24

< Cassette Mechanism Section >

■ Removing the Playback, Recording and Eraser Heads (See Fig.1~3)

1. While shifting the trigger arms seen on the right side of the head mount in the arrow direction, turn the flywheel R in counterclockwise direction until the head mount has gone out with a click (See Fig. 1).
2. When the flywheel R is rotated in counterclockwise direction, the playback head will be turned in counterclockwise direction from the position in Fig. 2 to that in Fig. 3.
3. At this position, disconnect the flexible P.C. board (outgoing from the playback head) from the connector CN301 on the head amp. and mechanism control P.C. board.
4. After dismantling the FPC holder, remove the flexible P.C. board.
5. Remove the flexible P.C. board from the chassis base.
6. Remove the spring "a" from behind the playback head.
7. Loosen the reversing azimuth screw retaining the playback head.
8. Take out the playback head from the front of the head mount.
9. The recording and eraser heads should also be removed similarly according to Steps 1~8 above.

● Reassembling the Playback, Recording and Eraser Heads (See Fig.2,3)

1. Reassemble the playback head from the front of the head mount to the position as shown in Fig. 3.
2. Fix the reversing azimuth screw.
3. Set the spring a from behind the playback head.
4. Attach the flexible P.C. board to the chassis base, and fix it with the FPC holder as shown in Fig. 3.
5. The recording and eraser heads should also be reassembled similarly according to steps 1~4 above.

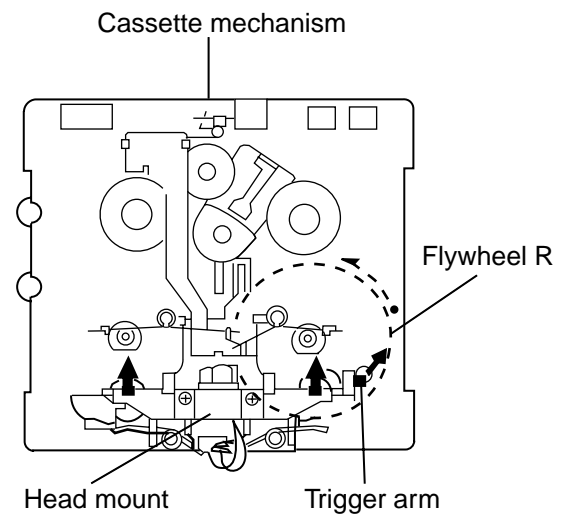

Fig. 1 (Mechanism A side)

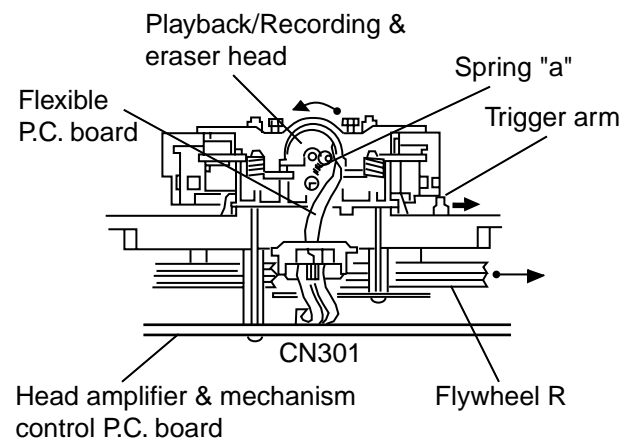

Fig. 2 (Mechanism A side)

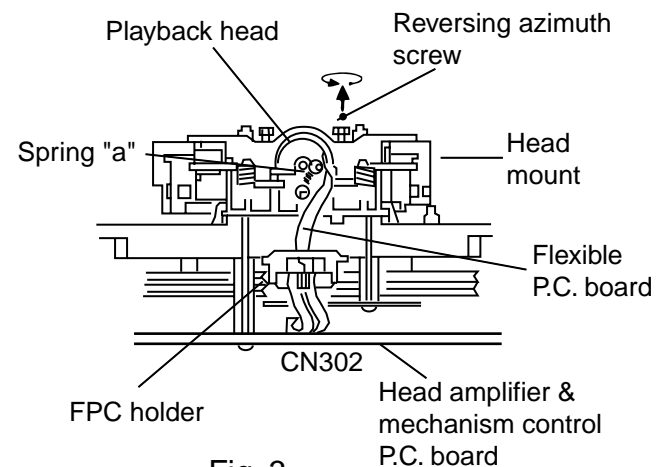

Fig. 3 (Mechanism B side)

**■ Removing the Head Amplifier. and Mechanism Control P.C. Board
(See Fig. 4)**

1. Remove the cassette mechanism assembly.
2. After turning over the cassette mechanism assembly, remove the five screws "A" retaining the head amp. and mechanism control P.C. board
3. Disconnect the connectors CN303 and CN304 on the P.C. board and the connectors CN1 on both the right and left side reel pulse P.C. boards.
4. When necessary, remove the 4 pin parallel wire soldered to the main motor.

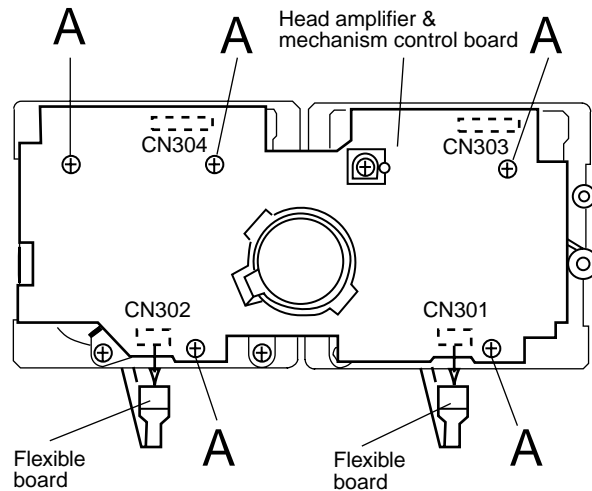

Fig. 4

**■ Removing the Capstan Motor Assembly
(See Fig. 5 to 7)**

1. Remove the six screws "B" retaining capstan motor assembly (See Fig. 5).
2. While raising the capstan motor, remove the capstan belts A and B respectively from the motor pulley (See Fig. 6).

Caution 1: Be sure to handle the capstan belts so carefully that these belts will not be stained by grease and other foreign matter. Moreover, these belts should be hand while referring to the capstan belt hanging method.

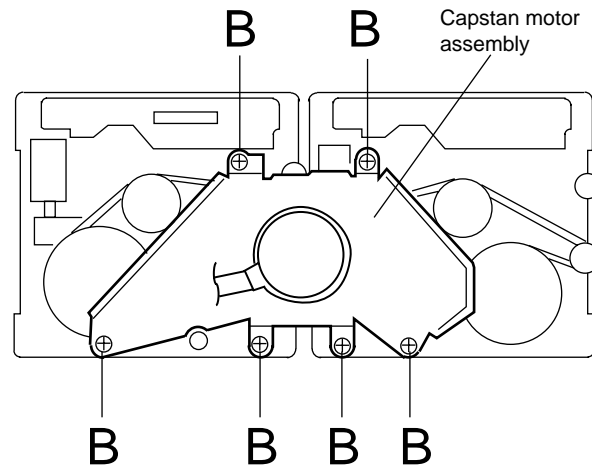

Fig. 5

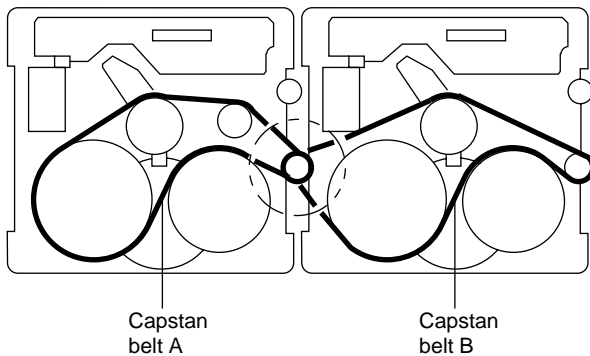

Fig. 7

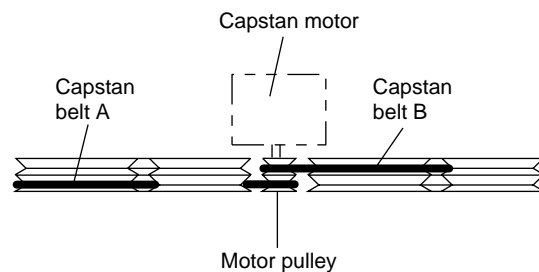

Fig. 6

■ Removing the Capstan Motor (See Fig. 8)

From the joint bracket, remove the two screws "C" retaining the capstan motor.

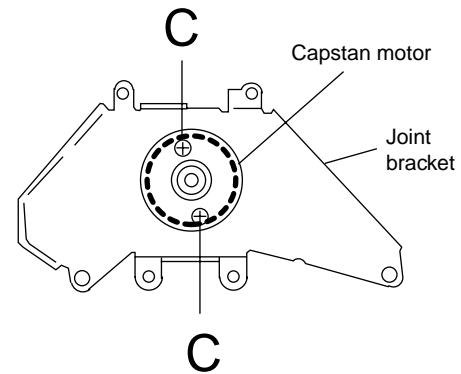

Fig. 8

■ Removing the Flywheel (See Fig. 9,10)

1. Remove the head amp. and mechanism control P.C. Board.
2. Remove the capstan motor assembly.
3. After turning over the cassette mechanism, remove the slit washers "a" and "b" fixing the capstan shafts R and L, and pull out the flywheels R and L respectively from behind the cassette mechanism.

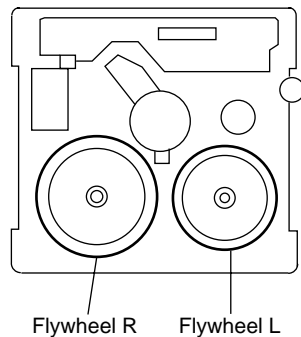

Fig. 10

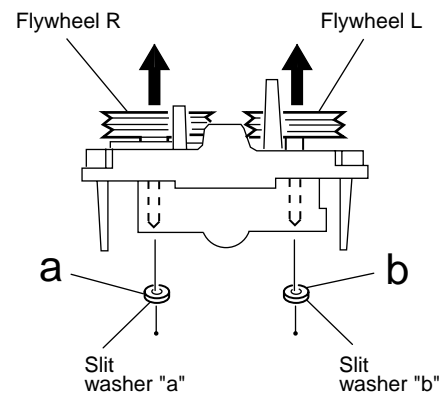

Fig. 9

■ Removing the Reel Pulse P.C. Board and Solenoid (See Fig. 11)

1. Remove the five pawls (c, d, e, f, g) retaining the reel pulse P.C. board.
2. From the surface of the reel pulse P.C. board parts, remove the two pawls "h" and "i" retaining the solenoid.

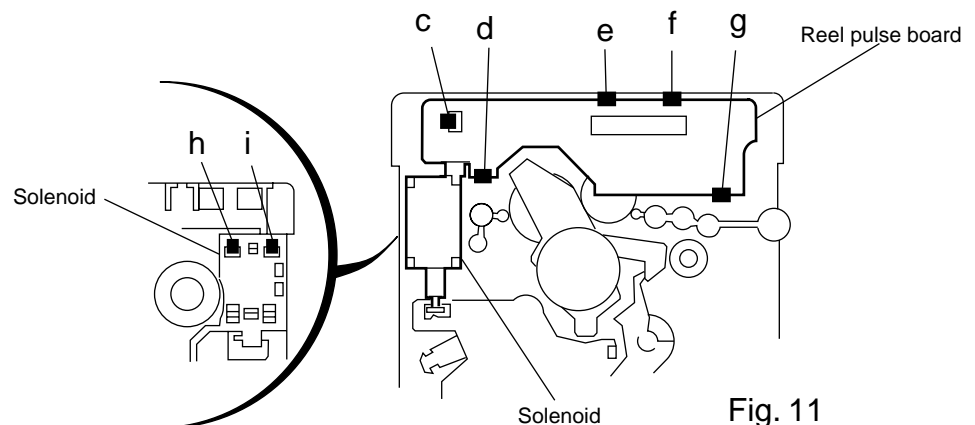

Fig. 11

Adjustment method

Measurement instruments required for adjustment

1. Low frequency oscillator,
This oscillator should have a capacity to output 0dBs with a termination of 600ohm impedance at an oscillation frequency of 50Hz-20kHz.
2. Attenuator impedance : 600 ohm
3. Electronic voltmeter
4. Frequency counter
5. Wow flutter meter
6. Test tape
VT712 : For Tape speed and wow flutter (3kHz)
VT724 : For Reference level (1kHz)
VT703L : For Head angle (10kHz)

In case of using frequency-mixed tape with 63,1k,10k and 14kHz(250nWb/m -24dB), use this tape together with a filter.

7. Blank tape
TAPE : AC-225
8. Torque gauge : For play and back tension
Forward ; TW2111A, Reverse ; TW2121A
Fast Forward and Rewind ; TW2231A
9. Test disc
: VT-501(12cm)
10. Jitter meter

Measurement conditions

Power supply voltage
AC110/127/230-240V(50Hz)

Measurement
output terminal : Speaker out
:TP101
(Measuring for TUNER / DECK / CD / DVD)
:Dummy load 6ohm

Radio input signal

AM modulation frequency : 400Hz
Modulation factor : 30%
FM modulation frequency : 400Hz
Frequency displacement : 22.5kHz

Frequency Range

AM 531kHz~1602kHz (9kHz step)
530kHz~1600kHz (10kHz step)
FM 87.5MHz~108MHz

Standard measurement positions of volume and switch

Power : Standby (Light STANDBY Indicator)
Sub woofer VOL. : Minimum
Sound mode : OFF
Main VOL. : 0 Minimum
Traverse mecha set position : Disc 1
Mic MIX VOL : MAX
ECHO : OFF

Precautions for measurement

1. Apply 30pF and 33k ohm to the IF sweeper output side and 0.082 μ F and 100kohm in series to the sweeper input side.
2. The IF sweeper output level should be made as low as possible within the adjustable range.
3. Since the IF sweeper is a fixed device, there is no need to adjust this sweeper.
4. Since a ceramic oscillator is used, there is no need to perform any MPX adjustment.
5. Since a fixed coil is used, there is no need to adjust the FM tracking.
6. The input and output earth systems are separated.
In case of simultaneously measuring the voltage in both of the input and output systems with an electronic voltmeter for two channels, therefore, the earth should be connected particularly.
7. In the case of BTL connection amplifier, the minus terminal of speaker is not for earthing. Therefore, be sure not to connect any other earth terminal to this terminal. This system is not BTL system.

■ Arrangement of adjusting positions

Cassette mechanism section (Mechanism A section)

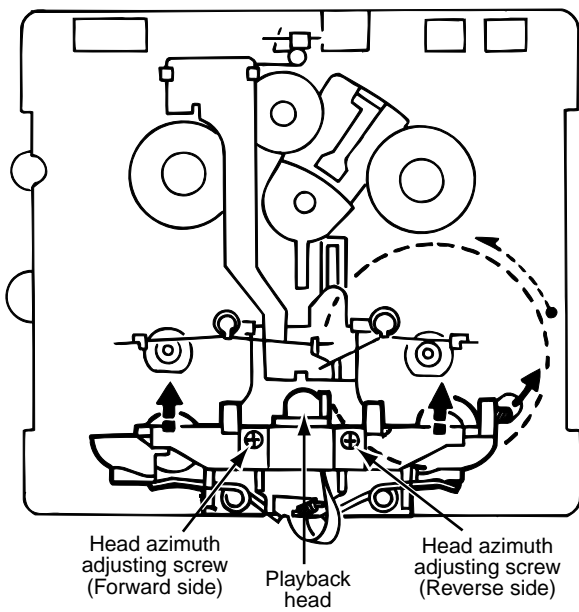

Cassette mechanism section (Back side)

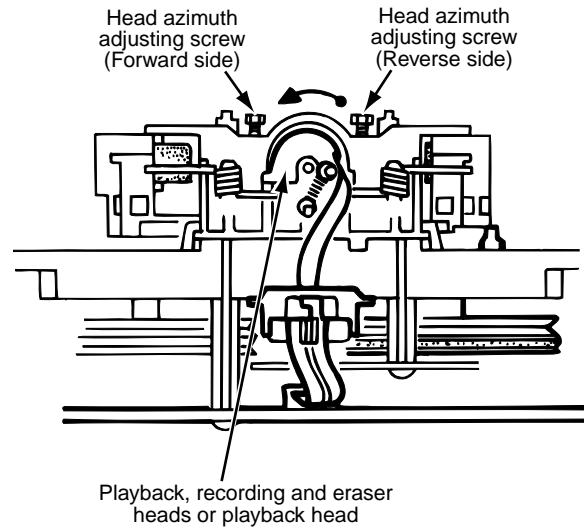

Cassette Mechanism Unit Section

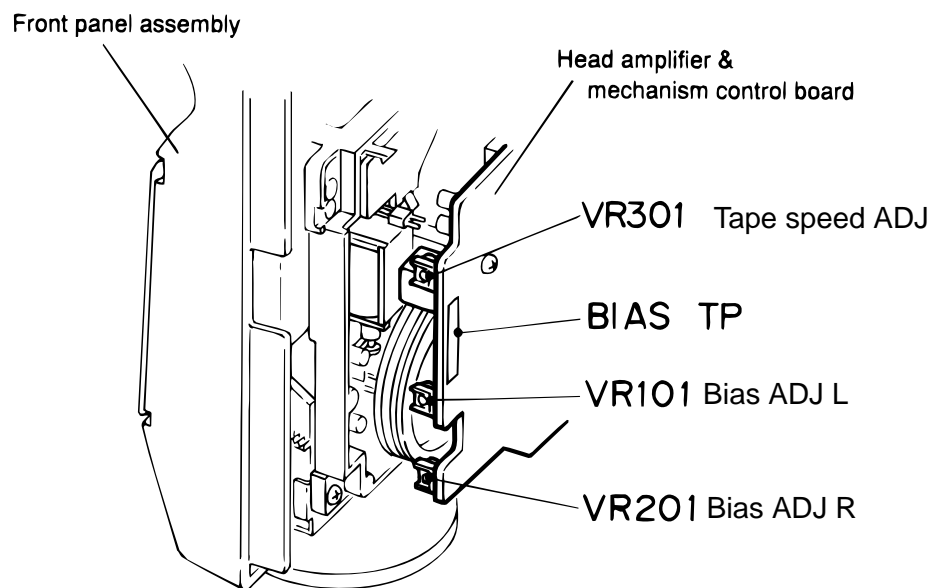

■ Tape recorder section

| Items | Measurement conditions | Measurement method | Standard values | Adjusting positions |
|----------------------------|---|---|---|--|
| Confirmation of head angle | Test tape :VT703L (10kHz) Measurement output terminal :Speaker terminal Speaker R (Load resistor :6Ω) :Headphone terminal | 1. Playback the test tape VT703L (10kHz). 2. With the playback mechanism or recording & playback mechanism, adjust the head azimuth screw so that the forward and reverse output levels become maximum. After adjustment, lock the head azimuth at least by half a turn. 3. In either case, this adjustment should be performed in both the forward and reverse directions with the head azimuth screw. | Maximum output | Adjust the head azimuth screw only when the head has been changed. |
| Confirmation of tape speed | Test tape :VT712 (3kHz) Measurement output terminal :Headphone terminal | <Constant speed> Adjust VR301 so that the frequency counter reading becomes 3,000Hz±60Hz when playing back the test tape VT712 (3kHz) with the playback mechanism or playback and recording mechanism after ending forward winding of the tape. | Tape speed of decks (A and B) :3,000Hz ±60Hz | VR301 |

■ Reference values for confirmation items

| Items | Measurement conditions | Measurement method | Standard values | Adjusting positions |
|--|--|---|-------------------------|--|
| Difference between the forward and reverse speed. P. mecha and R/P mecha speed | Test tape :VT703L(10kHz) Measurement output terminal :Speaker terminal Speaker R (Load resistance :6Ω) measurement output terminal :Headphone terminal | When the test tape VT712 (3kHz) has been played back with the playback mechanism or recording and playback mechanism at the beginning of forward winding, the frequency counter reading of the difference between both of the mechanisms should be 6.0Hz or less. | 60Hz or less | Both the playback and recording & playback mechanism |
| Wow & flutter | Test tape :VT712(3kHz) Measurement output terminal :Headphone terminal | When the test tape VT712(3kHz) has been played back with the playback mechanism or recording and playback mechanism at the beginning of forward winding the frequency counter reading of wow & flutter should be 0.25% or less (WRMS). | with in 0.25% JIS (WTD) | Both the playback and recording & playback mechanism |

■ Electrical performance

| Items | Measurement conditions | Measurement method | Standard values | Adjusting positions |
|--|---|--|--|----------------------------|
| Adjustment of recording bias current (Reference value) | *Mode : Forward or reverse mode *Recording mode *Test tape : AC-225 Measurement output terminal : Both recording and headphone terminals | <ol style="list-style-type: none"> 1. With the recording and playback mechanism, load the test tapes (AC-225 to TYPI), and set the mechanism to the recording and pausing conditions in advance. 2. After connecting $100\ \Omega$ in series to the recorder head, measure the bias current with a valve voltmeter at both of the terminals. 3. After resetting the [PAUSE] mode, start recording. At this time, adjust VR101 for LcH and VR201 for RcH so that the recording bias current values become $4.0\ \mu\text{A}$ (TYPI). | AC-225 : $4.20\ \mu\text{A}$ | LcH : VR101 RcH : VR201 |
| Adjustment of recording and playback frequency characteristics | Reference frequency : 1kHz and 10kHz (REF: -20dB) Test tape : TYP I AC-225 Measurement input terminal : OSC IN | <ol style="list-style-type: none"> 1. With the recording and playback mechanism, load the test tape (AC-225 to TYPI), and set the mechanism to the recording and pausing condition in advance. 2. While repetitively inputting the reference frequency signal of 1kHz and 10kHz from OSC IN, record and playback the test tape. 3. While recording and playing back the test tape in TYP I , adjust VR101 for LcH and VR201 for RcH so that the output deviation between 1kHz and 10kHz becomes $-1\text{dB} \pm 2\text{dB}$. | Output deviation between 1kHz and 10kHz : $-1\text{dB} \pm 2\text{dB}$ | LcH : VR101 RcH : VR201 |

■ Reference values for electrical function confirmation items

| Items | Measurement conditions | Measurement method | Standard values | Adjusting positions |
|----------------------------------|---|---|--------------------------|---------------------|
| Recording bias frequency | *Recording and playback side forward or reverse *Test tape : TYP I AC-225 *Measurement terminal BIAS TP on P.C. board | <ol style="list-style-type: none"> 1. With the recording and playback mechanism, load the test tape (AC-225 to TYP I), and set the mechanism to the recording and pausing conditions in advance. 2. Confirm that the BIAS TP frequency on the P.C. board is $100\text{kHz} \pm 6\text{kHz}$. | 100kHz +9kHz -7kHz | |
| Eraser current (Reference value) | *Recording and playback side forward or reverse *Recording mode *Test tape : AC-225 Measurement terminal Both of the eraser head | <ol style="list-style-type: none"> 1. With the recording and playback mechanism, load the test tapes (AC-225 to TYPI), and set the mechanism to the recording and pausing condition in advance. 2. After setting to the recording conditions, connect $1\text{M}\ \Omega$ in series to the eraser head on the recording and playback mechanism side, and measure the eraser current from both of the eraser terminal. | TYP I : 75mA | |

■ DVD section

TEST MODE FOR DVD and to INITIALISE THE DVD UNIT BOARD

a) Insert A/C Power Cord

b) At standby mode press **Stop Button** and **CANCEL/DEMO** button.

Wait 4 seconds for the display of " TEST VERSION REGION " i.e. TEST JC 1

c) Press the 'ENTER' button on remote. The FL panel will display 'EEPROM'.

Plug out and plug in again the power cord. Repeat the process 1(a) and 1(b) again.
Confirm that the Area Code and Region Code is correctly display as below.

| Area Code | FL indicate of Area Code in Test mode | Region Code. |
|-----------|---------------------------------------|--------------|
| J/C | JC | 1 |
| UJ | JC | 1 |
| UG/UX | 2U | 2 |
| US/UN/UP | 3U | 3 |
| UT | UT | 3 |
| UW | 4U | 4 |
| E/EN/B | E | 2 |
| A | A | 4 |
| EE | EE | 5 |

Note: Please plug out and plug in the power cord from A/C supply before continue the next test.

Adjustment

Jig set up

1. Remove the rubber cushion from each of the four corners of the traverse mechanism.
2. (When installing be sure not to make a mistake with the cushion colors).
3. Install the jig stud.

Make a jig clamp (Remove the clamp from the set and assemble it as shown in the diagram below).

Note:

How to handle the pickup

To protect the pickup from electro-static damage, make sure to hold it by the die-cast chassis (optical base). And make sure that pickup lens do not touch the top cover.

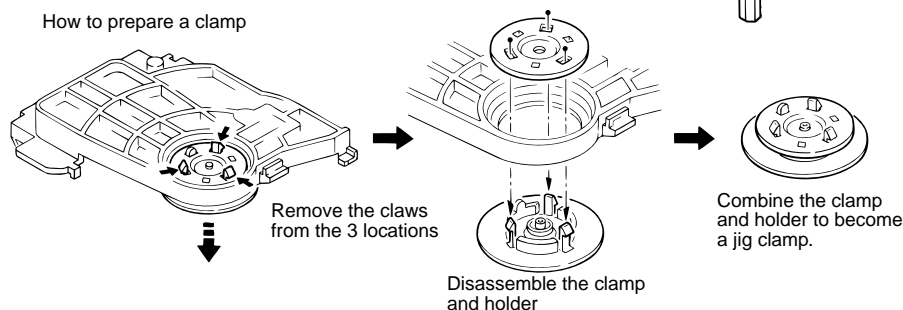
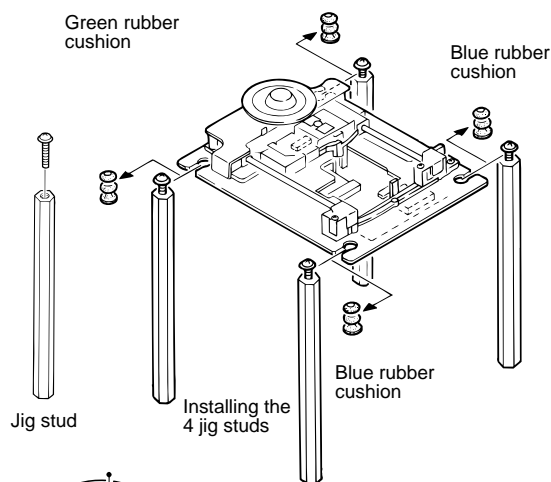

■ Integrated wiring for adjustment
(See Fig.1 to 3)

1. Place a board on top of the unit and put the changer on it. Then carry out the wiring of the main unit.
2. Connect a extension cable to the traverse mechanism for adjustment and then connect them to the changer.
3. Remove the solder of the short-circuited flexible wire. Then remove the short-circuited pin from the traverse mechanism.
4. Connection is completed.

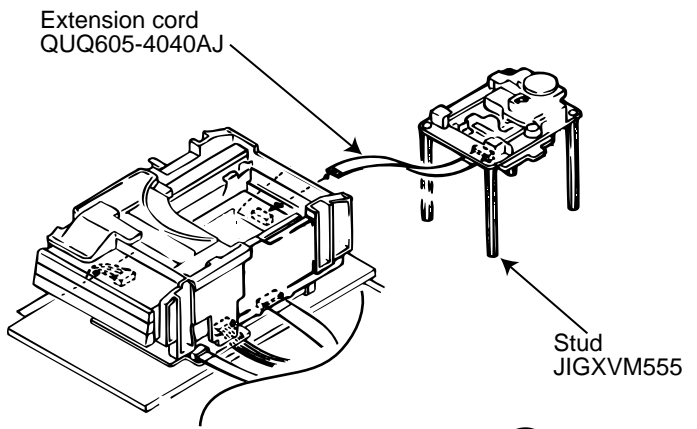

■ Adjustment preparation (See Fig.1 to 3)

1. The 3 adjustment locations.
2. 1.4 mm hexagonal wrench.
3. Set the VT501 or VT502 test disc.

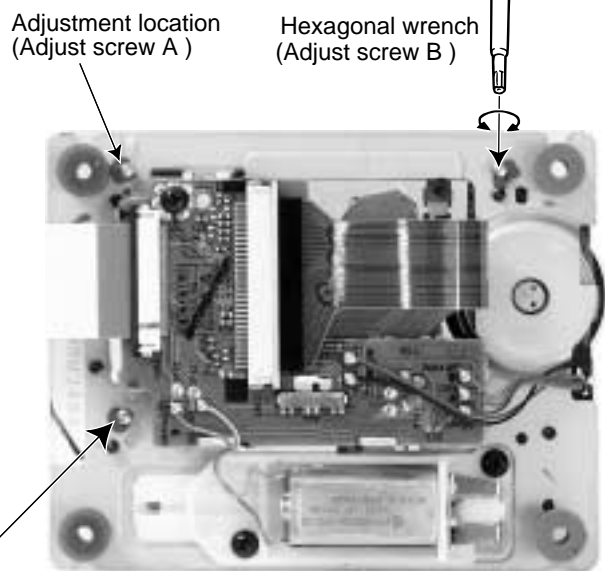

■ FL jitter display

(See Fig.1 to 3)

1. During standby Demo Mode when AC plug in. Press and hold "STOP" and "CANCEL/DEMO" button on the unit. ---*THE display will show "TEST 303" on the FL display.
2. When the key ▷ (PLAY) is pressed the jitter value is displayed. Ensure that the disc VT-501 or VT-502 is in the tray.
3. Adjust the jitter value to minimum by using the adjust screw.
 - a). Turn the adjustment screw (A and B) clockwise half.
 - b). Return the adjustment screw (A and B) to former position.
 - c). Set the adjustment screw (A and B) to the position of best jitter at three positions.

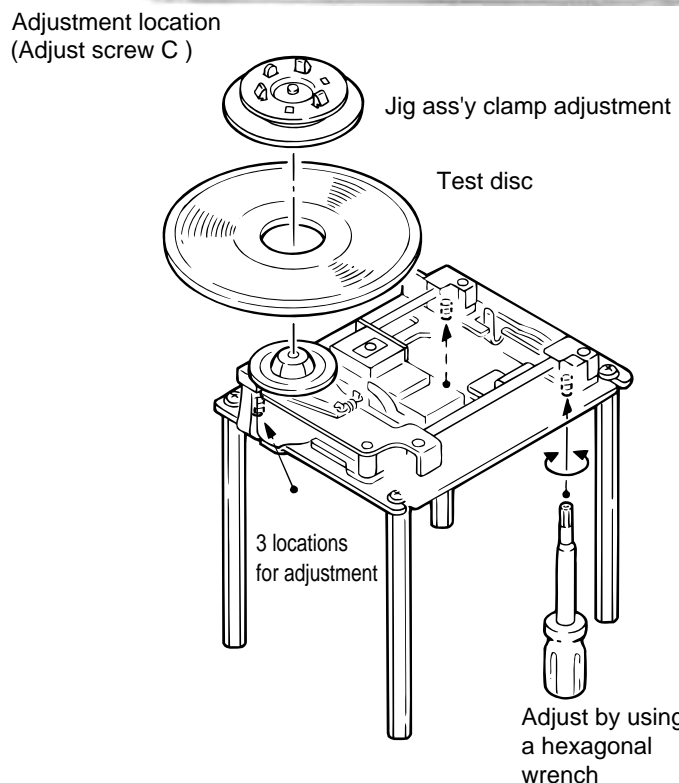

Next, do it similar to the above-mentioned in adjustment screw A and C.

■ Display of "Laser current value and" "Jitter value"

"Laser current value" and "Jitter value" are displayed on the FL display by the undermentioned method. Please refer to the failure diagnosis.

- 1) Take out the disc and close the tray.
- 2) Unplug the power plug.
- 3) Insert power plug into outlet while pressing both "STOP" button and "CANCEL / DEMO" button.
- 4) FL Display indicate "LASE 3U3", depend on its area and region code.
- 5) Press the "OPEN / CLOSE" button to move the tray outward.
Put the test disc (VT-501) on the tray and press "OPEN / CLOSE" button.
The tray should move inward (Note:Don't push to close the tray directly by hand etc.)
- 6) Press the "PLAY" button.
- 7) After a few seconds, The laser current value and the jitter value is displayed on the FL indicator as follows.

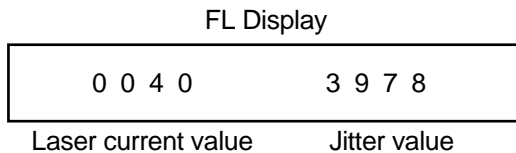

* The test mode is canceled when the power is turned off.

■ For Laser current value

The laser current value becomes 40mA for the above-mentioned.

Becomes a test mode by doing above-mentioned procedure 1) - 4). Afterwards, the laser current value can be switched by pushing the button to remote controller without turning on the disk.

Remote control "4" button --- Laser of CD
Remote control "5" button --- Laser of DVD

*Returns to a usual test mode by the thing to push the "CLEAR" button of remote controller.

If the laser current value is 64mA or less, it is roughly good. There is a possibility to which pick-up is deteriorated, please change the pick-up when there is 65mA or more laser current value.

■ For Jitter value

The jitter value is displayed by the hexadecimal number and please refer to the conversion table below. If the indication value is 11% or less, it can be judged by this simple checking method that the signal read precision of the set is satisfactory.

Before using the TEST disc VT-501, careful check it if there is neither damage nor dirt on the read surface.

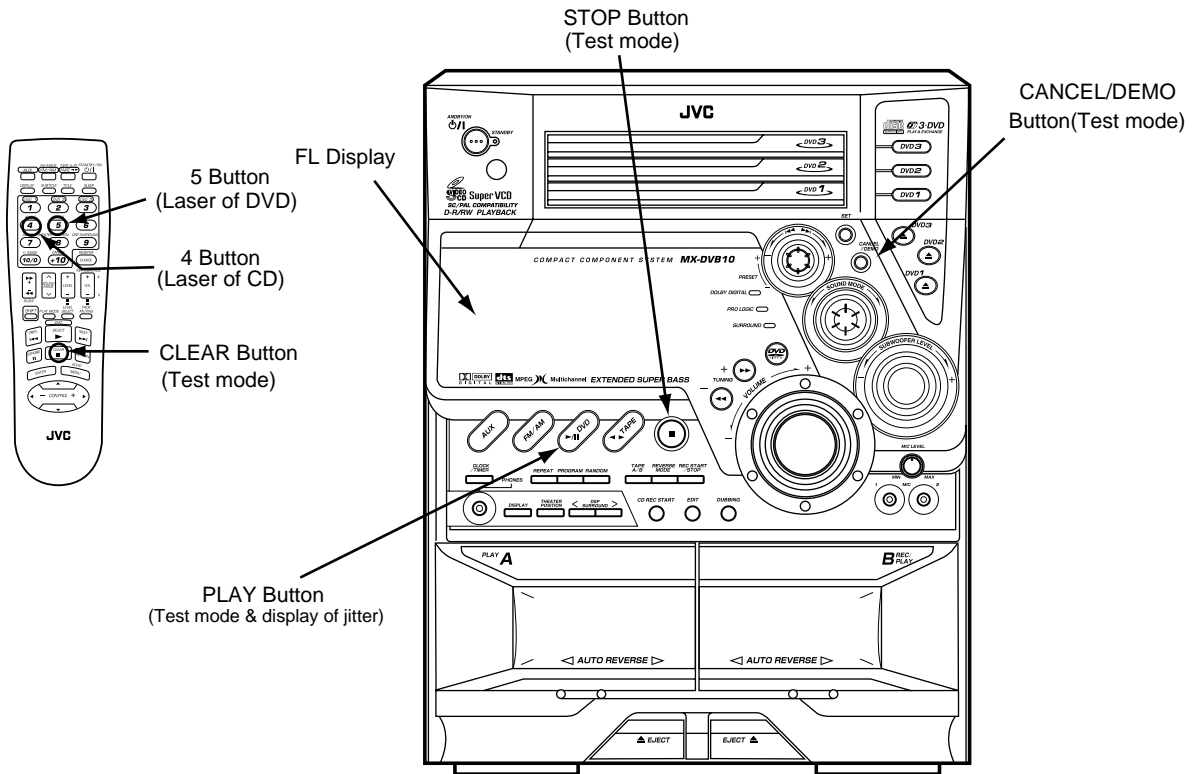

■ Jitter value

| FL display | Conversion value(%) | FL display | Conversion value(%) | FL display | Conversion value(%) | FL display | Conversion value(%) |
|------------|---------------------|------------|---------------------|------------|---------------------|------------|---------------------|
| 3818 | 4.7 | 3998 | 7.6 | 3B18 | 10.5 | 3C98 | 13.3 |
| 3828 | 4.8 | 39A8 | 7.7 | 3B28 | 10.6 | 3CA8 | 13.5 |
| 3838 | 4.9 | 39B8 | 7.8 | 3B38 | 10.7 | 3CB8 | 13.6 |
| 3848 | 5.1 | 39C8 | 7.9 | 3B48 | 10.8 | 3CC8 | 13.7 |
| 3858 | 5.2 | 39D8 | 8.1 | 3B58 | 10.9 | 3CD8 | 13.8 |
| 3868 | 5.3 | 39E8 | 8.2 | 3B68 | 11.1 | 3CE8 | 13.9 |
| 3878 | 5.4 | 39F8 | 8.3 | 3B78 | 11.2 | 3CF8 | 14.1 |
| 3888 | 5.5 | 3A18 | 8.5 | 3B88 | 11.3 | 3D18 | 14.3 |
| 3898 | 5.7 | 3A28 | 8.7 | 3B98 | 11.4 | 3D28 | 14.4 |
| 38A8 | 5.8 | 3A38 | 8.8 | 3BA8 | 11.5 | 3D38 | 14.5 |
| 38b8 | 5.9 | 3A48 | 8.9 | 3BB8 | 11.7 | 3D48 | 14.7 |
| 38c8 | 6.0 | 3A58 | 9.0 | 3BC8 | 11.8 | 3D58 | 14.8 |
| 38d8 | 6.1 | 3A68 | 9.1 | 3BD8 | 11.9 | 3D68 | 14.9 |
| 38E8 | 6.3 | 3A78 | 9.3 | 3BE8 | 12.0 | 3D78 | 15.0 |
| 38F8 | 6.4 | 3A88 | 9.4 | 3BF8 | 12.1 | 3D88 | 15.1 |
| 3918 | 6.6 | 3A98 | 9.5 | 3C18 | 12.4 | 3D98 | 15.3 |
| 3928 | 6.7 | 3AA8 | 9.6 | 3C28 | 12.5 | 3DA8 | 15.4 |
| 3938 | 6.9 | 3AB8 | 9.7 | 3C38 | 12.7 | 3DB8 | 15.5 |
| 3948 | 7.0 | 3AC8 | 9.9 | 3C48 | 12.7 | 3DC8 | 15.6 |
| 3958 | 7.1 | 3AD8 | 10.0 | 3C58 | 12.9 | 3DD8 | 15.7 |
| 3968 | 7.2 | 3AE8 | 10.1 | 3C68 | 13.0 | 3DE8 | 15.9 |
| 3978 | 7.3 | 3AF8 | 10.2 | 3C78 | 13.1 | 3DF8 | 16.0 |
| 3988 | 7.5 | | | 3C88 | 13.2 | | |

Maintenance of laser pickup

- (1) Cleaning the pick up lens
Before you replace the pick up, please try to clean the lens with a alcohol soaked cotton swab.
- (2) Life of the laser diode
When the life of the laser diode has expired, the following symptoms will appear.
- 1. The level of RF output (EFM output : amplitude of eye pattern) will define as below.

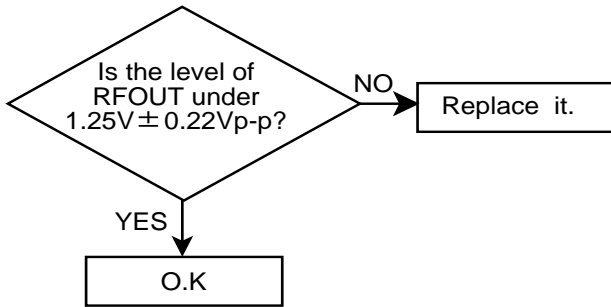

Replacement of laser pickup

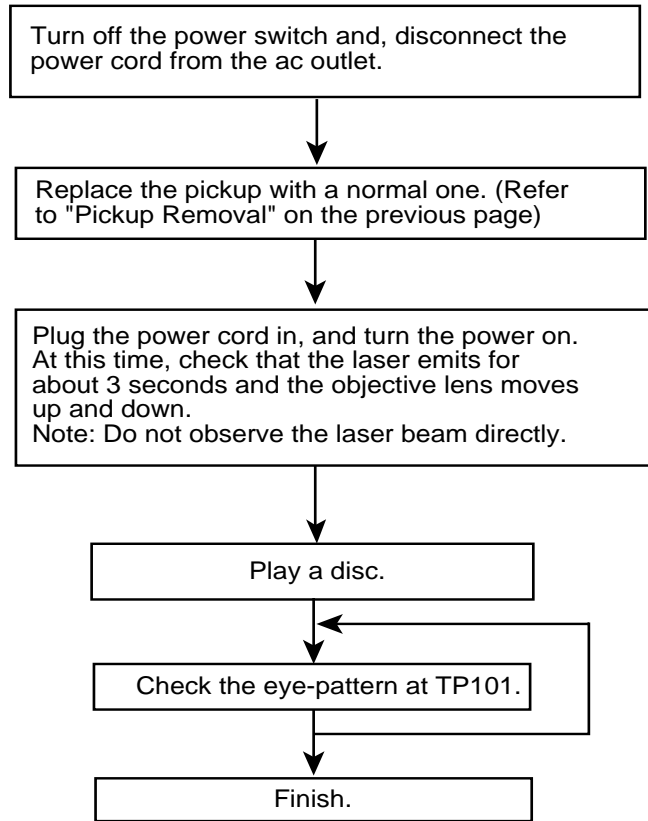

(3) Semi-fixed resistor on the APC PC board

The semi-fixed resistor on the APC printed circuit board which is attached to the pickup is used to adjust the laser power. Since this adjustment should be performed to match the characteristics of the whole optical block, do not touch the semi-fixed resistor.

If the laser power is lower than the specified value, the laser diode is almost worn out, and the laser pickup should be replaced.

If the semi-fixed resistor is adjusted while the pickup is functioning normally, the laser pickup may be damaged due to excessive current.

Flow of functional operation until TOC read

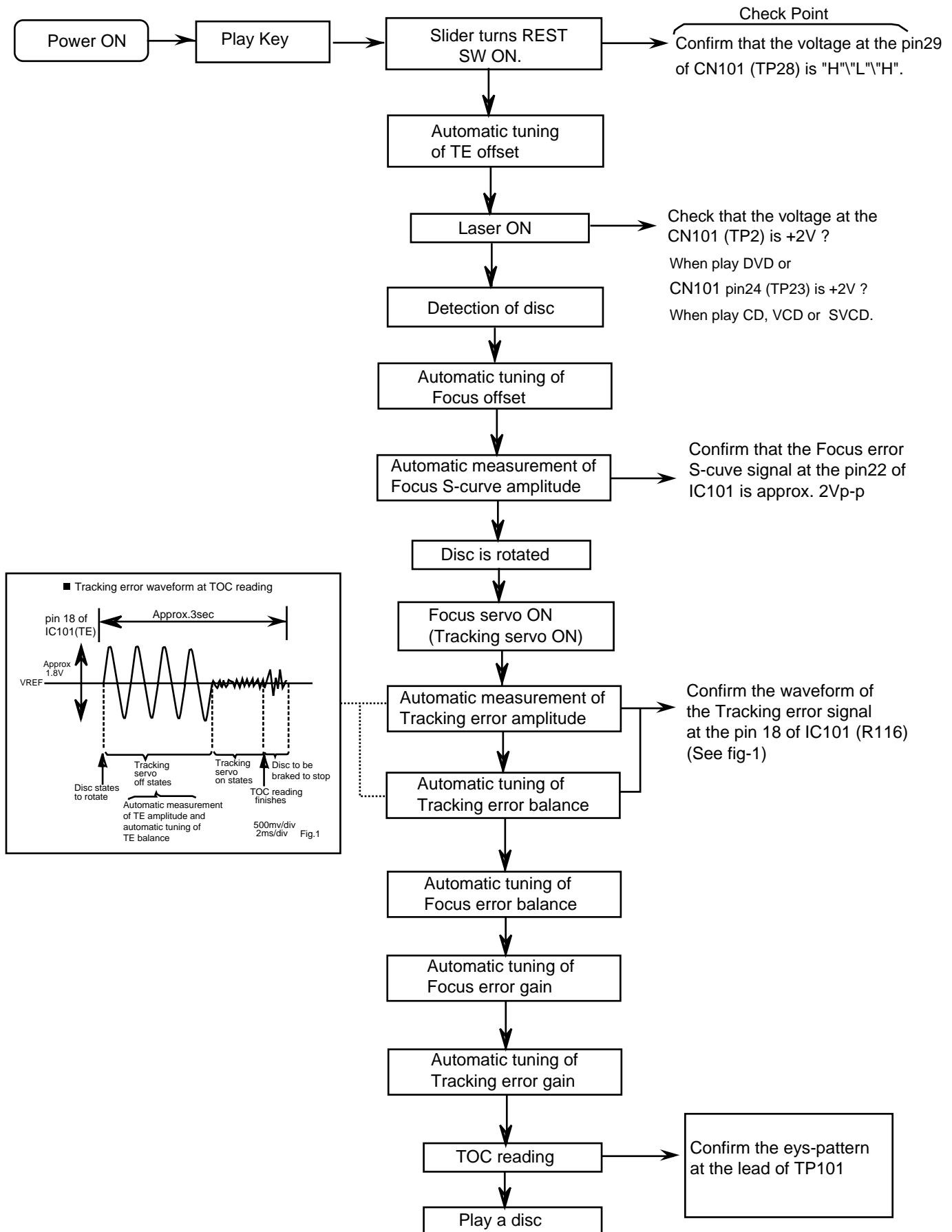

Description of major ICs

■ MN101C35DEG (IC810) : System control & FL driver

1. Pin layout

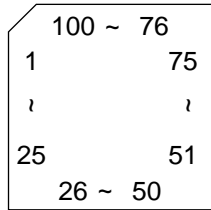

2. Pin function

| Pin No. | Symbol | I/O | Function |
|---------|-------------------|-----|---|
| 1 | SYSOUT | I | DVD signal output |
| 2 | SYSIN | O | DVD signal input |
| 3 | DVDCLK | I | DVD signal clock |
| 4 | DATAOUT | O | Tuner signal output |
| 5 | DATAIN | I | Tuner signal input |
| 6 | TUCLK | I | Tuner signal clock |
| 7 | DVDCS | I | DVD signal data input |
| 8 | VDD | - | Power supply |
| 9 | OSC2 | I | External terminal for main clock |
| 10 | OSC1 | O | External terminal for main clock |
| 11 | VSS | - | Connect to GND |
| 12 | X1 | - | Connect to GND |
| 13 | NC | - | No connect |
| 14 | MMOD | - | Connect to GND |
| 15 | VDRF- | - | Connect to GND |
| 16 | KEY1 | I | Key input terminal 1 |
| 17 | KEY2 | I | Key input terminal 2 |
| 18 | KEY3 | I | Key input terminal 3 |
| 19 | KEY4 | I | Key input terminal 4 |
| 20 | SLCKEY1 | I | SLC key input 1 |
| 21 | SLCKEY2 | I | SLC key input 2 |
| 22 | H/P-IN | O | Head phone signal output |
| 23 | SPIDTI | I | FL level data input |
| 24 | VREF+ | I | Reference voltage terminal |
| 25 | SMODE+ | I | Surround volume control input |
| 26 | RST | I | Reset input |
| 27 | BASSVOL+ | O | E.volume control signal output + |
| 28 | BASSVOL- | O | E.volume control signal output - |
| 29 | ECHO2 | O | Echo switching control 2 |
| 30 | RDSDATA /ECHO1 | O | Echo switching control 1 |
| 31 | SPIA | O | FL level control signal A |
| 32 | SPIB | O | FL level control signal B |
| 33 | REMAIN | I | Remote control signal input |
| 34 | PHOTOA | I | Reel pulse detection A |
| 35 | PHOTOB | I | Reel pulse detection B |
| 36 | DVDHBSY | O | DVD signal input |
| 37 | RDSCLK | O | Serial clock switching for RDS and Echo 2 |
| 38 | PRT | I | Power amplifier output protect detection |
| 39 | VOL1CE | O | E.volume data chip enable |
| 40 | VSCE | O | System bus chip enable |
| 41 | POUT | O | Power ON control output |
| 42 | FVOLDA | O | E.volume control data output |
| 43 | VOLCK | O | E.volume data communication clock |

| Pin No. | Symbol | I/O | Function |
|---------|----------|-----|------------------------------------|
| 44 | EXIT1 | O | Chip enable for EXT.IC |
| 45 | SLCCE | O | Chip enable for SLC control |
| 46 | DVDRST | O | DVD reset |
| 47 | G17 | O | FL drive control |
| 48 | G16 | O | FL drive control |
| 49 | G15 | O | FL drive control |
| 50 | G14 | O | FL drive control |
| 51 | G13 | O | FL drive control |
| 52 | G12 | O | FL drive control |
| 53 | G11 | O | FL drive control |
| 54 | G10 | O | FL drive control |
| 55 | G9 | O | FL drive control |
| 56 | G8 | O | FL drive control |
| 57 | G7 | O | FL drive control |
| 58 | G6 | O | FL drive control |
| 59 | G5 | O | FL drive control |
| 60 | G4 | O | FL drive control |
| 61 | G3 | O | FL drive control |
| 62 | G2 | O | FL drive control |
| 63 | G1 | O | FL drive control |
| 64 | P22 | O | FL drive control |
| 65 | P21 | O | FL drive control |
| 66 | P20 | O | FL drive control |
| 67 | P19 | O | FL drive control |
| 68 | P18 | O | FL drive control |
| 69 | P17 | O | FL drive control |
| 70 | P16 | O | FL drive control |
| 71 | P15 | O | FL drive control |
| 72 | P14 | O | FL drive control |
| 73 | P13 | O | FL drive control |
| 74 | P12 | O | FL drive control |
| 75 | P11 | O | FL drive control |
| 76 | P10 | O | FL drive control |
| 77 | P9 | O | FL drive control |
| 78 | P8 | O | FL drive control |
| 79 | P7 | O | FL drive control |
| 80 | P6 | O | FL drive control |
| 81 | P5 | O | FL drive control |
| 82 | P4 | O | FL drive control |
| 83 | P3 | O | FL drive control |
| 84 | P2 | O | FL drive control |
| 85 | P1 | O | FL drive control |
| 86 | TUCE | O | Tuner control chip enable |
| 87 | VOL2CE | O | Volume control chip enable |
| 88 | VSCLK | O | Volume clock |
| 89 | DVD1LED | O | Disc 1 LED drive |
| 90 | DVD2LED | O | Disc 2 LED drive |
| 91 | DVD3LED | O | Disc 3 LED drive |
| 92 | R_SEARCH | I | Tuner signal detection |
| 93 | MSI | I | Detection between the broadcasting |
| 94 | MPX | I | Stereo signal detection |
| 95 | INH | O | Tuner signal inhibit |
| 96 | F_SEARCH | | Tuner signal detection |
| 97 | VOL- | | Volume drive control |
| 98 | VOL+ | | Volume drive control |
| 99 | SMODE- | O | Sub woofer volume control |
| 100 | VPP | I | Power supply |

MN103S13BDA (IC301) : Optical disc controller

1. Pin layout

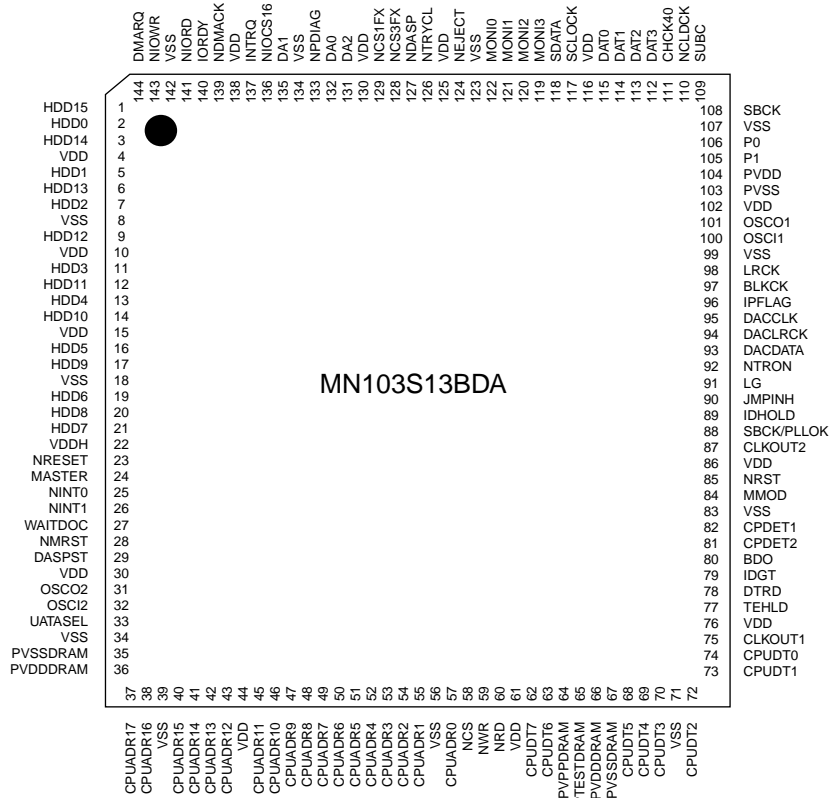

2. Block diagram

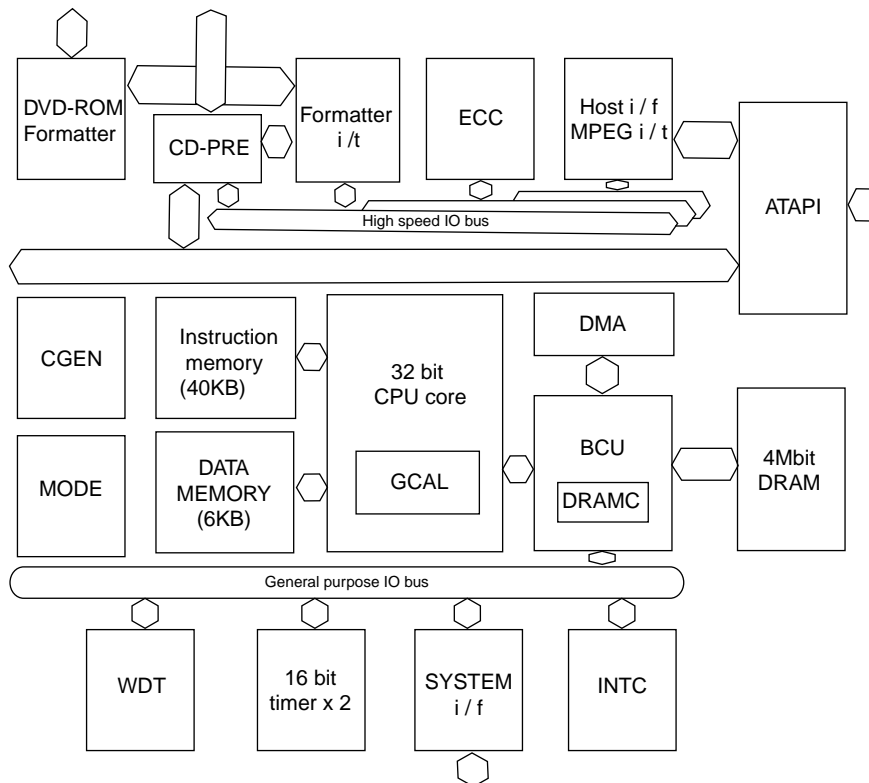

3. Pin function (1/3)

| Pin No. | Symbol | I/O | Description |
|---------|----------|-----|--|
| 1 | HDD15 | I/O | ATAPI Data |
| 2 | HDD0 | I/O | ATAPI Data |
| 3 | HDD14 | I/O | ATAPI Data |
| 4 | VDD | - | Power supply 3V |
| 5 | HDD1 | I/O | ATAPI Data |
| 6 | HDD13 | I/O | ATAPI Data |
| 7 | HDD2 | I/O | ATAPI Data |
| 8 | VSS | - | Connect to GND |
| 9 | HDD12 | I/O | ATAPI Data |
| 10 | VDD | - | Power supply 2.7V |
| 11 | HDD3 | I/O | ATAPI Data |
| 12 | HDD11 | I/O | ATAPI Data |
| 13 | HDD4 | I/O | ATAPI Data |
| 14 | HDD10 | I/O | ATAPI Data |
| 15 | VDD | - | Power supply 3V |
| 16 | HDD5 | I/O | ATAPI Data |
| 17 | HDD9 | I/O | ATAPI Data |
| 18 | VSS | - | Connect to GND |
| 19 | HDD6 | I/O | ATAPI Data |
| 20 | HDD8 | I/O | ATAPI Data |
| 21 | HDD7 | I/O | ATAPI Data |
| 22 | VDDH | | |
| 23 | NRESET | I | ATAPI Reset input |
| 24 | MASTER | I/O | ATAPI Master/slave select |
| 25 | NINT0 | O | Interruption of system control 0 |
| 26 | NINT1 | O | Interruption of system control 1 |
| 27 | WAITDOC | O | Wait control of system control |
| 28 | NMRST | O | Reset of system control (Connect to TP302) |
| 29 | DASPST | I | Setting of initial value of DASP signal |
| 30 | VDD | - | Power supply 3V |
| 31 | OSCO2 | O | Non connect |
| 32 | OSCI2 | I | Non connect |
| 33 | UATASEL | I | Connect to VSS |
| 34 | VSS | - | Connect to GND |
| 35 | PVSSDRAM | | Connect to VSS |
| 36 | PVDDDRAM | | Connect to VDD(2.7V) |
| 37 | CPUADR17 | I | System control address |
| 38 | CPUADR16 | I | System control address |
| 39 | VSS | - | Connect to GND |
| 40 | CPUADR15 | I | System control address |
| 41 | CPUADR14 | I | System control address |
| 42 | CPUADR13 | I | System control address |
| 43 | CPUADR12 | I | System control address |
| 44 | VDD | - | Power supply 2.7V |
| 45 | CPUADR11 | I | System control address |
| 46 | CPUADR10 | I | System control address |
| 47 | CPUADR9 | I | System control address |
| 48 | CPUADR8 | I | System control address |
| 49 | CPUADR7 | I | System control address |
| 50 | CPUADR6 | I | System control address |

3. Pin function (2/3)

| Pin No. | Symbol | I/O | Description |
|---------|------------|-----|---|
| 51 | CPUADR5 | I | System control address |
| 52 | CPUADR4 | I | System control address |
| 53 | CPUADR3 | I | System control address |
| 54 | CPUADR2 | I | System control address |
| 55 | CPUADR1 | I | System control address |
| 56 | VSS | - | Connect to GND |
| 57 | CPUADR0 | I | System control address |
| 58 | NCS | I | System control chip select |
| 59 | NWR | I | Writing system control |
| 60 | NRD | I | Reading system control |
| 61 | VDD | - | Power supply 3V |
| 62 | CPUDT7 | I/O | System control data |
| 63 | CPUDT6 | I/O | System control data |
| 64 | PVPPDRAM | O | Connect to VSS |
| 65 | PTESTDRAM | I | Connect to VSS |
| 66 | PVDDDRAM | | Connect to VDD(2.7V) |
| 67 | PVSSDRAM | | Connect to VSS |
| 68 | CPUDT5 | I/O | System control data |
| 69 | CPUDT4 | I/O | System control data |
| 70 | CPUDT3 | I/O | System control data |
| 71 | VSS | - | Connect to GND |
| 72 | CPUDT2 | I/O | System control data |
| 73 | CPUDT1 | I/O | System control data |
| 74 | CPUDT0 | I/O | System control data |
| 75 | CLKOUT1 | O | Clock signal output (16.9/11.2/8.45MHz) |
| 76 | VDD | - | Power supply 3V |
| 77 | TEHLD | O | Mirror gate (Connect to TP141) |
| 78 | DTRD | O | Data frequency control switch (Connect to TP304) |
| 79 | IDGT | O | CAPA switch |
| 80 | BDO | I | RF Dropout/BCA data |
| 81 | CPDET2 | I | Outer capacity detection |
| 82 | CPDET1 | I | Inner capacity detection |
| 83 | VSS | - | Connect to GND |
| 84 | MMOD | I | Connect to VSS |
| 85 | NRST | I | System reset |
| 86 | VDD | - | Power supply 3V |
| 87 | CLKOUT2 | O | Clock 16.9MHz |
| 88 | SBCK/PLLOK | O | Flame mark detection |
| 89 | IDOHOLD | O | ID gate for tracking holding |
| 90 | JMPINH | O | Jump prohibition |
| 91 | LG | O | Land/group switch |
| 92 | NTRON | I | Tracking ON |
| 93 | DACDATA | O | Serial data output (Connect to TP148) |
| 94 | DACLCK | O | Identification signal of L and R (Connect to TP149) |
| 95 | DACCLK | I | Clock for serial data output |
| 96 | IPFLAG | I | Input of IP flag |
| 97 | BLKCK | I | Sub code/block/input clock |
| 98 | LRCK | I | Identification signal of L and R (Connect to VSS) |
| 99 | VSS | - | Connect to GND |
| 100 | OSCI1 | I | Oscillation input terminal 16.9MHz |

3. Pin function (3/3)

| Pin No. | Symbol | I/O | Description |
|---------|---------|-----|--|
| 101 | OSCO1 | O | Oscillation output terminal 16.9MHz |
| 102 | VDD | - | Power supply 3V |
| 103 | PVSS | - | Connect to GND |
| 104 | PVDD | - | Power supply 3V |
| 105 | P1 | I/O | Terminal master polarity switch input |
| 106 | P0 | I/O | CIRC-RAM,OVER/UNDER Interruption |
| 107 | VSS | - | Connect to GND |
| 108 | SBCK | O | Clock output for sub code,serial input |
| 109 | SUBC | I | Sub code,serial input |
| 110 | NCLDCK | I | Sub code,flame clock input |
| 111 | CHCK40 | I | Clock is read to DAT3~0 (Output of division frequency from ADSC) |
| 112 | DAT3 | I | Data is read from disc (Going side by side output from ADSC) |
| 113 | DAT2 | I | Data is read from disc (Going side by side output from ADSC) |
| 114 | DAT1 | I | Data is read from disc (Going side by side output from ADSC) |
| 115 | DAT0 | I | Data is read from disc (Going side by side output from ADSC) |
| 116 | VDD | - | Power supply 3V |
| 117 | SCLOCK | I/O | Debug serial clock (270 ohm pull up) |
| 118 | SDATA | I/O | Debug serial data (270 ohm pull up) |
| 119 | MONI3 | O | Internal good title monitor (Connect to TP150) |
| 120 | MONI2 | O | Internal good title monitor (Connect to TP151) |
| 121 | MONI1 | O | Internal good title monitor (Connect to TP152) |
| 122 | MONI0 | O | Internal good title monitor (Connect to TP153) |
| 123 | VSS | - | Connect to GND |
| 124 | NEJECT | I | Eject detection |
| 125 | VDD | - | Power supply 2.7V |
| 126 | NTRYCL | I | Non connect (Tray close detection) |
| 127 | NDASP | I/O | ATAPI drive active / slave connect I/O |
| 128 | NCS3FX | I | Non connect (ATAPI host chip select) |
| 129 | NCS1FX | I | Non connect (ATAPI host chip select) |
| 130 | VDD | - | Power supply 3V |
| 131 | DA2 | I/O | ATAPI host address |
| 132 | DA0 | I/O | Non connect (ATAPI host address) |
| 133 | NPDIAG | I/O | ATAPI Slave master diagnosis input |
| 134 | VSS | - | Connect to GND |
| 135 | DA1 | I/O | Non connect (ATAPI host address) |
| 136 | NIOCS16 | O | Output of selection of width of ATAPI host data bus |
| 137 | INTRQ | O | ATAPI Host interruption output |
| 138 | VDD | - | Power supply 3V |
| 139 | NDMACK | I | Non connect (ATAPI Host DMA characteristic) |
| 140 | IORDY | O | ATAPI Host ready output (Connect to TP157) |
| 141 | NIORD | I | Non connect (ATAPI host read) |
| 142 | VSS | - | Connect to GND |
| 143 | NIOWR | I/O | ATAPI Host write |
| 144 | DMARQ | O | ATAPI Host DMA request (Connect to TP159) |

■ MN101C49GEH 1 (IC500) : AV decoder

1. Pin layout

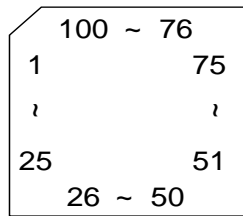

2. Pin function

| Pin No. | Symbol | I/O | Function |
|---------|----------|-----|---|
| 1 | VREF | I | Reference voltage |
| 2 | NC | - | No connect |
| 3 | NC | - | No connect |
| 4 | NC | - | No connect |
| 5 | NTSEL | I | NTSC/PAL selection |
| 6 | POWER SW | - | No connect |
| 7 | SHUT1 | - | No connect |
| 8 | KEY1-5 | - | No connect |
| 9 | KEY6-10 | - | No connect |
| 10 | VREF+ | I | Reference voltage |
| 11 | VDD | I | Power supply |
| 12 | OSC2 | O | External terminal for connected oscirator |
| 13 | OSC1 | I | External terminal for connected oscirator |
| 14 | VSS | - | Connect to GND |
| 15 | XI | I | External terminal for sub oscirator (Supply to voltage) |
| 16 | XO | O | No connect |
| 17 | MMOD | I | connects with gnd |
| 18 | DADATA | I/O | Data bus for DAC |
| 19 | DACS1 | I/O | Serial bus S1 for DAC |
| 20 | DCLK | I/O | Clock for DAC |
| 21 | S2UDT | O | Communication between unit microcomputers DATA output |
| 22 | U2SDT | I | Communication between unit microcomputers DATA output |
| 23 | SCLK | I/O | Serial clock bus |
| 24 | BUSY | I/O | Busy bus |
| 25 | CPURST | O | Unit microcomputer reset |
| 26 | REQ | I | Commnication between unit microcomputers REQ |
| 27 | REMO | I | Remote control interruption |
| 28 | TEST1 | - | Test terminal |
| 29 | TEST2 | - | Test terminal |
| 30 | TEST3 | - | Test terminal |
| 31 | DVDCS | I | Chip select for DVD |
| 32 | NC | - | No connect |
| 33 | DVDRST | I | DVD reset |
| 34 | NC | - | No connect |
| 35 | DACS2 | I/O | Serial bus S2 for DAC |
| 36 | DACS3 | I/O | Serial bus S3 for DAC |
| 37 | NC | - | No connect |
| 38 | NC | - | No connect |
| 39 | FS2 | I | Over sampling frequency |
| 40 | CHREQ | I | Changer commnication REQUEST |
| 41 | CHST | O | Changer commnication STROBE |
| 42 | CHDATA | O | Changer commnication DATA I/O |
| 43 | NC | - | No connect |

| Pin No. | Symbol | I/O | Function |
|---------|-----------|-----|--------------------------------|
| 44 | CHCK | I | Channel clock |
| 45 | DVDOUT | O | DVD data output |
| 46 | DVDIN | I | DVD data input |
| 47 | DVDCLK | I | DVD clock |
| 48 | DVDBSY | | Busy bus for DVD |
| 49 | NC | - | No connect |
| 50 | NC | - | No connect |
| 51 | NC | - | No connect |
| 52 | NC | - | No connect |
| 53 | NC | - | No connect |
| 54 | VS1 | O | Fanction SW control |
| 55 | VS3 | O | Fanction SW control |
| 56 | SL/SRMUTE | O | No connect |
| 57 | CMUTE | O | Center signal output mute |
| 58 | SWMUTE | O | No connect |
| 59 | POB2 | O | No connect |
| 60 | DEMP2 | O | No connect |
| 61 | DEMP1 | O | No connect |
| 62 | DENA | O | No connect |
| 63 | KARAOKE | O | No connect |
| 64 | POWER ON | O | Power on control output |
| 65 | VS2 | O | Fanction SW control |
| 66 | NC | - | No connect |
| 67 | NC | - | No connect |
| 68 | NC | - | No connect |
| 69 | NC | - | No connect |
| 70 | NC | - | No connect |
| 71 | NC | - | No connect |
| 72 | NC | - | No connect |
| 73 | NC | - | No connect |
| 74 | NC | - | No connect |
| 75 | NC | - | No connect |
| 76 | NC | - | No connect |
| 77 | AVCI | I | Power supply |
| 78 | AVCO | I/O | AV compu link signal I/O port |
| 79 | RGB | I | RGB signal in |
| 80 | STD | IND | O Standby LED output |
| 81 | MPX1 | I | MPX1 signal input |
| 82 | MPX2 | I | MPX2 signal input |
| 83 | SRELAY | O | S. Relay control |
| 84 | MRELAY | O | M. Relay control |
| 85 | BASS1 | O | BASS1 switching |
| 86 | BASS2 | O | BASS2 switching |
| 87 | FCD | O | CD power supply control signal |
| 88 | PBMUTE | O | PB mute |
| 89 | AUXMUTE | O | AUX mute |
| 90 | SMUTE | O | System mute output |
| 91 | NC | - | No connect |
| 92 | NC | - | No connect |
| 93 | NC | - | No connect |
| 94 | NC | - | No connect |
| 95 | DAVSS | - | Connect to GND |
| 96 | NC | - | No connect |
| 97 | NC | - | No connect |
| 98 | NC | - | No connect |
| 99 | HPMUTE | O | Head phone mute |
| 100 | VREF- | I | Connected GND |

■ ZIVA-4.1 PA2 (IC501) : AV decoder

1. Pin layout

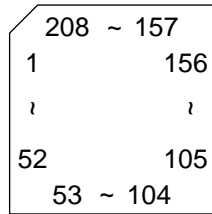

2. Pin function (1/5)

| Pin No. | Symbol | I/O | Description |
|---------|--------|-----|---|
| 1 | RD | I | Read strobe input |
| 2 | R/W | I | Read/write strobe input |
| 3 | VDD | - | Power supply terminal 3.3V |
| 4 | WAIT | O | Transfer not complete / data acknowledge. Active LOW to indicate host initiated transfer is complete. |
| 5 | RESET | I | Active LOW : reset signal input |
| 6 | VSS | - | Connect to ground |
| 7 | VDD | - | Power supply terminal 3.3V |
| 8 | INT | O | Host interrupt signal output |
| 9 | NC | - | Non connect |
| 10 | NC | - | Non connect |
| 11 | NC | - | Non connect |
| 12 | NC | - | Non connect |
| 13 | VDD | - | Power supply terminal 2.5V |
| 14 | VSS | - | Connect to ground |
| 15 | NC | - | Non connect |
| 16 | NC | - | Non connect |
| 17 | NC | - | Non connect |
| 18 | NC | - | Non connect |
| 19 | VSS | - | Connect to ground |
| 20 | VDD | - | Power supply 3.3V |
| 21 | VDATA0 | O | Video data bus output. Byte serial CbYCrY data synchronous with VCLK. |
| 22 | VDATA1 | O | Video data bus output. Byte serial CbYCrY data synchronous with VCLK. |
| 23 | VDATA2 | O | Video data bus output. Byte serial CbYCrY data synchronous with VCLK. |
| 24 | VDATA3 | O | Video data bus output. Byte serial CbYCrY data synchronous with VCLK. |
| 25 | VDATA4 | O | Video data bus output. Byte serial CbYCrY data synchronous with VCLK. |
| 26 | VDATA5 | O | Video data bus output. Byte serial CbYCrY data synchronous with VCLK. |
| 27 | VDATA6 | O | Video data bus output. Byte serial CbYCrY data synchronous with VCLK. |
| 28 | VDATA7 | O | Video data bus output. Byte serial CbYCrY data synchronous with VCLK. |
| 29 | VSYNC | I/O | Vertical sync. Bi-directional, the decoder output the top border of a new field on the first HSYNC after the falling edge of VSYNC. |
| 30 | HSYNC | I/O | Horizontal sync. The decoder begins outputting pixel data for a new horizontal line after the falling (active) edge of HSYNC. |
| 31 | VSS | - | Connect to ground |
| 32 | VDD | - | Power supply terminal 3.3V |
| 33 | NC | - | Non connect |
| 34 | NC | - | Non connect |
| 35 | NC | - | Non connect |
| 36 | VDD | - | Power supply terminal 2.5V |

2. Pin function (2/5)

| Pin No. | Symbol | I/O | Description |
|---------|---------|-----|---|
| 37 | VSS | - | Connect to ground |
| 38 | NC | - | Non connect |
| 39 | NC | - | Non connect |
| 40 | NC | - | Non connect |
| 41 | NC | - | Non connect |
| 42 | NC | - | Non connect |
| 43 | PIO0 | I/O | Programmable I/O terminal |
| 44 | VSS | - | Connect to ground |
| 45 | VDD | - | Power supply terminal 3.3V |
| 46 | PIO1 | I/O | Programmable I/O terminal |
| 47 | PIO2 | I/O | Programmable I/O terminal |
| 48 | PIO3 | I/O | Programmable I/O terminal |
| 49 | PIO4 | I/O | Programmable I/O terminal |
| 50 | PIO5 | I/O | Programmable I/O terminal |
| 51 | PIO6 | I/O | Programmable I/O terminal |
| 52 | PIO7 | I/O | Programmable I/O terminal |
| 53 | MDATA0 | I/O | SDRAM data |
| 54 | MDATA1 | I/O | SDRAM data |
| 55 | VDD | - | Power supply terminal 3.3V |
| 56 | VSS | - | Connect to ground |
| 57 | MDATA2 | I/O | SDRAM data |
| 58 | MDATA3 | I/O | SDRAM data |
| 59 | MDATA4 | I/O | SDRAM data |
| 60 | MDATA5 | I/O | SDRAM data |
| 61 | MDATA6 | I/O | SDRAM data |
| 62 | MDATA7 | I/O | SDRAM data |
| 63 | MDATA15 | I/O | SDRAM data |
| 64 | VDD | - | Power supply terminal 3.3V |
| 65 | VSS | - | Connect to ground |
| 66 | MDATA14 | I/O | SDRAM data |
| 67 | VDD | - | Power supply terminal 2.5 |
| 68 | VSS | - | Connect to ground |
| 69 | MDATA13 | I/O | SDRAM data |
| 70 | MDATA12 | I/O | SDRAM data |
| 71 | MDATA11 | I/O | SDRAM data |
| 72 | MDATA10 | I/O | SDRAM data |
| 73 | MDATA9 | I/O | SDRAM data |
| 74 | VDD | - | Power supply terminal 3.3V |
| 75 | VSS | - | Connect to ground |
| 76 | MDATA8 | I/O | SDRAM data |
| 77 | LDQM | O | SDRAM Lower or upper mask |
| 78 | SD-CLK | O | SDRAM Clock |
| 79 | CLKSEL | I | Selects SYSCCLK or VCLK as clock source. Normal operation is to tie HIGH. |
| 80 | MADDR9 | O | SDRAM address |
| 81 | MADDR8 | O | SDRAM address |
| 82 | VDD | - | Power supply terminal 3.3V |
| 83 | VSS | - | Connect to ground |
| 84 | MADDR7 | O | SDRAM address |

2. Pin function (3/5)

| Pin No. | Symbol | I/O | Description |
|---------|----------------|-----|--|
| 85 | MADDR6 | O | SDRAM address |
| 86 | MADDR5 | O | SDRAM address |
| 87 | VDD | - | Power supply terminal 2.5V |
| 88 | VSS | - | Connect to ground |
| 89 | MADDR4 | O | SDRAM address |
| 90 | MWE | O | SDRAM write enable |
| 91 | SD-CAS | O | Active LOW SDRAM column address |
| 92 | VDD | - | Power supply terminal 3.3V |
| 93 | VSS | - | Connect to ground |
| 94 | SD-RAS | O | Active LOW SDRAM row address |
| 95 | SD-CS0 | O | Active LOW SDRAM chip select 0 |
| 96 | SD-CS1/MADDR11 | O | Active LOW SDRAM chip select 1 or use as MADDR11 for larger SDRAM |
| 97 | SD-BS | O | SDRAM bank select |
| 98 | MADDR10 | O | SDRAM address |
| 99 | MADDR0 | O | SDRAM address |
| 100 | VDD | - | Power supply terminal 3.3V |
| 101 | VSS | - | Connect to ground |
| 102 | MADDR1 | O | SDRAM address |
| 103 | MADDR2 | O | SDRAM address |
| 104 | MADDR3 | O | SDRAM address |
| 105 | RESERVED | I | Tie to VSS or VDD_3.3 as specified in table1 |
| 106 | NC | - | Non connect |
| 107 | NC | - | Non connect |
| 108 | RESERVED | I | Tie to VSS or VDD_3.3 as specified in table1 |
| 109 | NC | - | Non connect |
| 110 | RESERVED | I | Tie to VSS or VDD_3.3 as specified in table1 |
| 111 | RESERVED | I | Tie to VSS or VDD_3.3 as specified in table1 |
| 112 | RESERVED | I | Tie to VSS or VDD_3.3 as specified in table1 |
| 113 | DAI-LRCK | I | PCM left/right clock |
| 114 | DAI-BCK | I | PCM input bit clock |
| 115 | VDD | - | Power supply 3.3V |
| 116 | VSS | - | Connect to ground |
| 117 | DAI-DATA | I | PCM data input |
| 118 | DA-DATA3 | O | PCM data output. Eight channels. Serial audio samples relative to DA_BCK and DA_LRCK |
| 119 | DA-DATA2 | O | PCM data output. Eight channels. Serial audio samples relative to DA_BCK and DA_LRCK |
| 120 | DA-DATA1 | O | PCM data output. Eight channels. Serial audio samples relative to DA_BCK and DA_LRCK |
| 121 | DA-DATA0 | O | PCM data output. Eight channels. Serial audio samples relative to DA_BCK and DA_LRCK |
| 122 | DA-LRCK | O | PCM left clock. Identifies the channel for each sample |
| 123 | VDD | - | Power supply terminal 3.3V |
| 124 | VSS | - | Connect to ground |
| 125 | DA-XCK | I/O | Audio external frequency clock input or output |
| 126 | DA-BCK | O | PCM bit clock output |
| 127 | DA-IEC | O | PCM data out in IEC-958 format or compressed data out in IEC-1937 format |
| 128 | VDD | - | Power supply terminal 2.5V |

2. Pin function (4/5)

| Pin No. | Symbol | I/O | Description |
|---------|--------------------|-----|--|
| 129 | VSS | - | Connect to ground |
| 130 | NC | - | Non connect |
| 131 | VSS_DAC | - | Connect to ground for analog video DAC |
| 132 | VSS_VIDEO | - | Connect to ground for analog video |
| 133 | CVBS | O | DAC video output format : CVBS. Macrovision encoded |
| 134 | VDD_DAC | - | Power supply terminal for analog video DAC |
| 135 | VDD_VIDEO | - | Power supply terminal for analog video |
| 136 | NC | - | Non connect |
| 137 | VSS_DAC | - | Connect to ground for analog video DAC |
| 138 | VSS_VIDEO | - | Connect to ground for analog video |
| 139 | CVBS/G/Y | O | DAC video output format. Macrovision encoded |
| 140 | VDD_DAC | - | Power supply terminal for analog video DAC |
| 141 | VDD_VIDEO | - | Power supply terminal for analog video |
| 142 | NC | - | Non connect |
| 143 | VSS_DAC | - | Connect to ground for analog video DAC |
| 144 | VSS_VIDEO | - | Connect to ground for analog video |
| 145 | Y/B/U | O | DAC video output format. Macrovision encoded |
| 146 | VDD_DAC | - | Power supply terminal for analog video DAC |
| 147 | VDD_VIDEO | - | Power supply terminal for analog video |
| 148 | NC | - | Non connect |
| 149 | VSS_DAC | - | Connect to ground for analog video DAC |
| 150 | VSS_VIDEO | - | Connect to ground for analog video |
| 151 | C/R/V | O | DAC video output format. Macrovision encoded |
| 152 | VDD_DAC | - | Power supply terminal for analog video DAC |
| 153 | VDD_VIDEO | - | Power supply terminal for analog video |
| 154 | VSS_RREF | - | Connect to ground for analog video |
| 155 | RREF | O | Reference resistor. Connecting to pin 154 |
| 156 | VDD_RREF | - | Power supply terminal for analog video 3.3V |
| 157 | A_VSS | - | Power supply terminal for analog PLL 3.3V |
| 158 | SYSCCLK | I | Optical system clock. Tie to A_VDD through a 1K ohm resistor |
| 159 | VCLK | I | System clock input |
| 160 | A_VDD | - | Power supply terminal for analog PLL 3.3V |
| 161 | DVD-DATA0/CD-DATA | I | Serial CD data. This pin is shared with DVD compressed data DVD-DATA0 |
| 162 | DVD-DATA1/CD-LRC | I | Programmable polarity 16-bit word synchronization to the decoder. This pin is shared with DVD compressed data DVD-DATA1 |
| 163 | DVD-DATA2/CD-BCK | I | CD bit clock. Decoder accept multiple BCK rates. This pin is shared with DVD compressed DVD-DATA2 |
| 164 | DVD-DATA3/CD-C2PO | I | Asserted HIGH indicates a corrupted byte. This pin is shared with DVD compressed data DVD-DATA3 |
| 165 | DVD-DATA4/CDGSDATA | I | DVD parallel compressed data from DVD DSP. or CD-G data indicating serial subcode data input |
| 166 | VSS | - | Connect to ground |
| 167 | VDD | - | Power supply terminal 3.3V |
| 168 | DVD-DATA5/CDG-VFSY | I | DVD parallel compressed data from DVD DSP. or CD-G frame sync indicating frame-start or composite synchronization input. |
| 169 | DVD-DATA6/CDG-SOS1 | I | DVD parallel compressed data from DVD DSP. or CD-G block sync indicating block-start synchronization input |

2. Pin function (5/5)

| Pin No. | Symbol | I/O | Description |
|---------|--------------------|-----|---|
| 170 | DVD-DATA7/CDG-SCLK | I | DVD parallel compressed data from DVD DSP. or CD-G clock indicating sub code data clock input or output |
| 171 | VDACK | I | In synchronous mode, bitstream data acknowledge. Asserted when DVD data is valid.Polarity is programmable |
| 172 | VREQUEST | O | Bitstream request |
| 173 | VSTROBE | I | Bitstream strobe |
| 174 | ERROR | I | Error in input data |
| 175 | VDD | - | Power supply terminal 3.3V |
| 176 | RESERVED | I | Tie to VSS or VDD_3.3 as specified in table 1 |
| 177 | VDD | - | Power supply terminal 3.3V |
| 178 | VSS | - | Connect to ground |
| 179 | NC | - | Non connect |
| 180 | RESERVED | I | Tie to VSS or VDD_3.3 as specified in table 1 |
| 181 | NC | - | Non connect |
| 182 | HADDR0 | I | Host addressbus. 3-bit address bus selects one of eight host interface registers |
| 183 | HADDR1 | I | Host addressbus. 3-bit address bus selects one of eight host interface registers |
| 184 | HADDR2 | I | Host addressbus. 3-bit address bus selects one of eight host interface registers |
| 185 | RESERVED | I | Tie to VSS or VDD_3.3 as specified in table 1 |
| 186 | RESERVED | I | Tie to VSS or VDD_3.3 as specified in table 1 |
| 187 | RESERVED | I | Tie to VSS or VDD_3.3 as specified in table 1 |
| 188 | VSS | - | Connect to ground |
| 189 | VDD | - | Power supply terminal 2.5V |
| 190 | RESERVED | I | Tie to VSS or VDD_3.3 as specified in table 1 |
| 191 | VSS | - | Connect to ground |
| 192 | VDD | - | Power supply terminal 3.3V |
| 193 | RESERVED | I | Tie to VSS or VDD_3.3 as specified in table 1 |
| 194 | RESERVED | I | Tie to VSS or VDD_3.3 as specified in table 1 |
| 195 | RESERVED | I | Tie to VSS or VDD_3.3 as specified in table 1 |
| 196 | RESERVED | I | Tie to VSS or VDD_3.3 as specified in table 1 |
| 197 | HDATA7 | I/O | The 8-bit bi-directional host data through which the host writes data to the decoder code. |
| 198 | VSS | - | Connect to ground |
| 199 | HDATA6 | I/O | The 8-bit bi-directional host data through which the host writes data to the decoder code. |
| 200 | HDATA5 | I/O | The 8-bit bi-directional host data through which the host writes data to the decoder code. |
| 201 | HDATA4 | I/O | The 8-bit bi-directional host data through which the host writes data to the decoder code. |
| 202 | HDATA3 | I/O | The 8-bit bi-directional host data through which the host writes data to the decoder code. |
| 203 | HDATA2 | I/O | The 8-bit bi-directional host data through which the host writes data to the decoder code. |
| 204 | VDD | - | Power supply terminal 3.3V |
| 205 | VSS | - | Connect to ground |
| 206 | HDATA1 | I/O | The 8-bit bi-directional host data through which the host writes data to the decoder code. |
| 207 | HDATA0 | I/O | The 8-bit bi-directional host data through which the host writes data to the decoder code. |
| 208 | CS | I | Host chip select input |

■ AN7345K (IC302) : REC/PRE Amp.

1. Pin layout / Block diagram

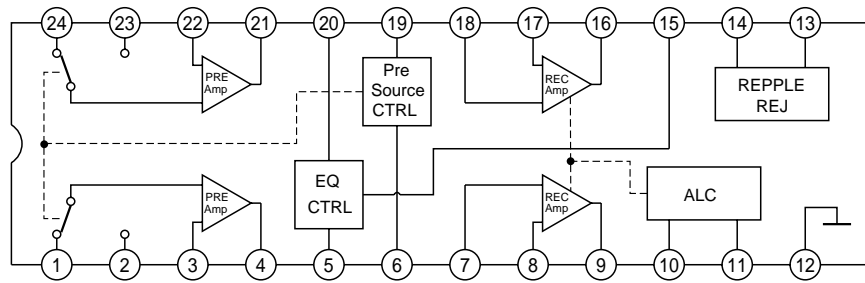

2. Pin function

| Pin No. | I/O | Function |
|---------|-----|---|
| 1 | I | CH1 Playback amplifier input(1) |
| 2 | I | CH1 Playback amplifier input(2) |
| 3 | I | CH1 Playback amplifier negative feedback |
| 4 | O | CH1 Playback amplifier output |
| 5 | I | CH1 Equalizer input |
| 6 | O | Pre amplifier input control time constant |
| 7 | I | CH1 Recoding amplifier input |
| 8 | I | CH1 Recoding amplifier negative output |
| 9 | O | CH1 Recoding amplifier output |
| 10 | O | ALC low cut |
| 11 | O | ALC L.P.F |
| 12 | - | Connect to GND |
| 13 | - | Power supply |
| 14 | O | Repple filter |
| 15 | I | Equalizer control |
| 16 | O | CH2 Recoding amplifier output |
| 17 | I | CH2 Recoding amplifier negative output |
| 18 | I | CH2 Recoding amplifier input |
| 19 | O | Pre amplifier input control |
| 20 | I | CH2 Equalizer input |
| 21 | O | CH2 Playback amplifier output |
| 22 | I | CH2 Playback amplifier negative feedback |
| 23 | I | CH2 Playback amplifier input(2) |
| 24 | I | CH2 Playback amplifier input(1) |

■ MN67706ZY (IC201) : Auto digital servo controller

1. Pin layout

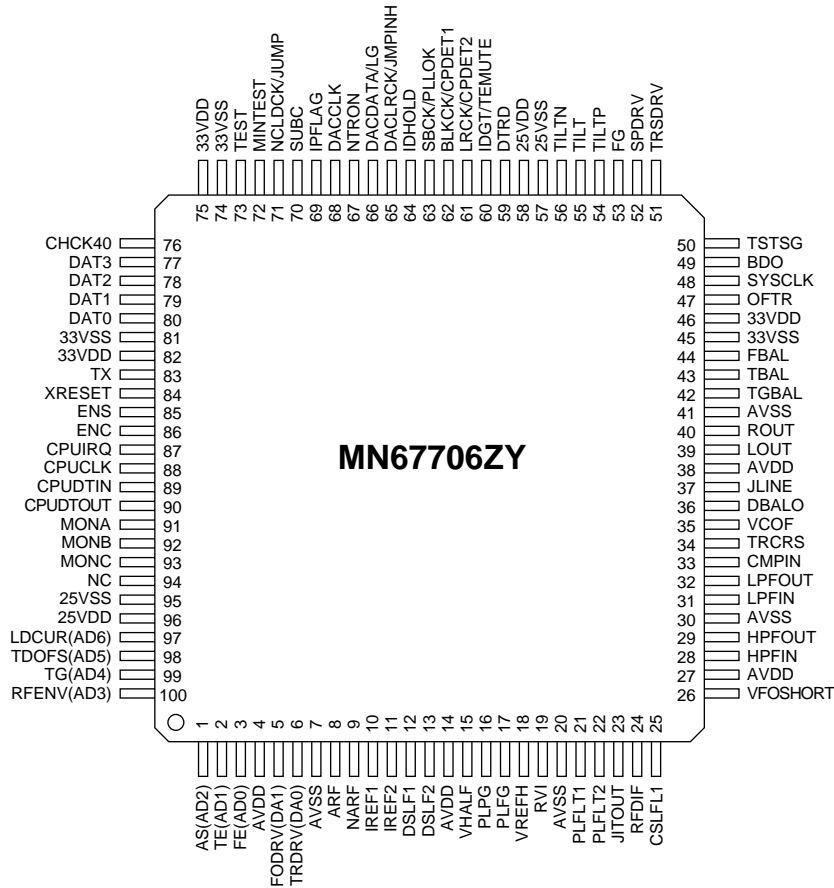

2. Pin functions (1/3)

| Pin No. | Symbol | I/O | Function |
|---------|------------|-----|---|
| 1 | AS(AD2) | I | AS : Full adder signal (FEP) |
| 2 | TE(AD1) | I | Phase difference / 3 beam tracking error(FEP) |
| 3 | FE(AD0) | I | Focus error (FEP) |
| 4 | AVDD | - | Apply 3.3V (For analog circuit) |
| 5 | FODRV(DA1) | O | Focus drive (DRVIC) |
| 6 | TRDRV(DA0) | O | Tracking drive (DRVIC) |
| 7 | AVSS | - | Ground (For analog circuit) |
| 8 | ARF | I | Equivalence RF+ (FEP) |
| 9 | NARF | I | Equivalence RF- (FEP) |
| 10 | IREF1 | I | Reference current1 (For DBAL) |
| 11 | IREF2 | I | Reference current2 (For DBAL) |
| 12 | DSLFL1 | I/O | Connect to capacitor1 for DSL |
| 13 | DSLFL2 | I/O | Connect to capacitor2 for DSL |
| 14 | AVDD | - | Apply 3.3V (For analog circuit) |
| 15 | VHALF | I | Reference voltage 1.65+0.1V (FEP) |
| 16 | PLPG | - | Not use(PLL phase gain setting resistor terminal) |
| 17 | PLFG | - | Not use(PLL frequency gain setting resistor terminal) |
| 18 | VREFH | I | Reference voltage 2.2V+0.1V (FEP) |
| 19 | RVI | I/O | Connect to resistor forVREFH reference current source |
| 20 | AVSS | - | Ground (For analog circuit) |
| 21 | PLFLT1 | O | Connect to capacitor1 for PLL |
| 22 | PLFLT2 | O | Connect to capacitor 2 for PLL |
| 23 | JITOUT | I/O | Output or jitter signal monitorf |
| 24 | RFDIF | I | Not use |
| 25 | CSLFL1 | I/O | Pull-up to VHALF |

2. Pin function (2/3)

| Pin No. | Symbol | I/O | Function |
|---------|---------------|-----|---|
| 26 | VFOSHORT | O | VFO short output |
| 27 | AVDD | - | Apply 3.3V(For analog circuit) |
| 28 | HPFIN | I | Pull-up to VHALF |
| 29 | HPFOUT | O | Connect to TP208 |
| 30 | AVSS | - | Ground(For analog circuit) |
| 31 | LPFIN | I | Pull-up to VHALF |
| 32 | LPFOUT | O | Not use |
| 33 | CMPIN | I | Connect to TP210 |
| 34 | TRCRS | I | Input signal for track cross formation |
| 35 | VCOF | I/O | JFVCO control voltage |
| 36 | DBALO | O | DSL balance adjust output |
| 37 | JLINE | O | J-line setting output(FEP) |
| 38 | AVDD | - | Apply 3.3V(For analog circuit) |
| 39 | LOUT | O | Connect to TP203 (Analog audio left output) |
| 40 | ROUT | O | Connect to TP204 (Analog audio right output) |
| 41 | AVSS | - | Ground(For analog circuit) |
| 42 | TGBAL | O | Tangential balance adjust(FEP) |
| 43 | TBAL | O | Tracking balance adjust(FEP) |
| 44 | FBAL | O | Focus balance adjust(FEP) |
| 45 | 33VSS | - | Ground(For I/O) |
| 46 | 33VDD | - | Apply 3.3V(For I/O) |
| 47 | OFTR | I | Off track signal |
| 48 | SYSCLK | I | 16.9344MHz system clock input(ODC) |
| 49 | BDO | I | Drop out(FEP) |
| 50 | TSTSG | O | Calibration signal(FEP) |
| 51 | TRSDRV | O | Traverse drive(DRVIC) |
| 52 | SPDRV | O | Spindle drive output(DRVIC) |
| 53 | FG | I | FG signal input (Spindle motor driver) |
| 54 | TILTP | O | Connect to TP205 |
| 55 | TILT | O | Connect to TP206 |
| 56 | TILTIN | O | Connect to TP207 |
| 57 | 25VSS | - | Ground(For internal core) |
| 58 | 25VDD | - | Apply 2.5V(For internal core) |
| 59 | DTRD | I | Data read control signal(ODC) |
| 60 | IDGT/TEMUTE | I | Pull-down to Ground |
| 61 | LRCK/CPDET2 | O | LR channel data strobe(ODC)/ |
| 62 | BLKCK/CPDET1 | O | CD sub code synchronous signal(ODC)/ |
| 63 | SBCK/PLLOK | I | CD sub code data shift clock(ODC)/PLL pull-in OK signal input |
| 64 | IDHOLD | I | Pull-down to Ground |
| 65 | DACLCK/JMPINH | I | 1bit DAC-LR channel data strobe(ODC)/ |
| 66 | DACDATA/LG | I | CD 1bit DAC channel data(ODC) |
| 67 | NTRON | O | L : Tracking ON(ODC) |
| 68 | DACCLK | O | 1bit DAC channel data shift clock(ODC) |
| 69 | IPFLAG | O | CIRC error flag(ODC) |
| 70 | SUBC | O | CD sub code(ODC) |
| 71 | NCLDCK/JUMP | O | CD sub code data frame clock(ODC)/DVD JUMP signal(ODC) |
| 72 | MINTEST | I | Pull-down to Ground(For MINTEST) |
| 73 | TEST | I | Pull-down to Ground(For TEST) |
| 74 | 33VSS | - | Ground(For I/O) |
| 75 | 33VDD | - | Apply 3.3V(For I/O) |
| 76 | CHCK40 | O | Clock for SRDATA(ODC) |
| 77 | DAT3 | O | SRDATA3(ODC) |
| 78 | DAT2 | O | SRDATA2(ODC) |
| 79 | DAT1 | O | SRDATA1(ODC) |
| 80 | DAT0 | O | SRDATA0(ODC) |

2. Pin function (3/3)

| Pin No. | Symbol | I/O | Function |
|---------|------------|-----|---|
| 81 | 33VSS | - | Ground (For I/O) |
| 82 | 33VDD | - | Apply 3.3V (For I/O) |
| 83 | TX | O | Digital audio interface |
| 84 | XRESET | I | Reset input (System control) |
| 85 | ENS | I | Servo DSC serial I/F chip select (System control) |
| 86 | ENC | I | CIRC serial I/F chip select (System control) |
| 87 | CPUIRQ | O | Interrupt request (System control) |
| 88 | CPUCLK | I | Syscon serial I/F clock (System control) |
| 89 | CPUDTIN | I | Syscon serial I/F data input (System control) |
| 90 | CPUDTOUT | O | Syscon serial I/F data output (System control) |
| 91 | MONA | O | Connect to TP226 (Monitor terminal A) |
| 92 | MONB | O | Connect to TP225 (Monitor terminal A) |
| 93 | MONC | O | Connect to TP224 (Monitor terminal A) |
| 94 | NC | O | Connect to TP211 |
| 95 | 25VSS | - | Ground (For internal core) |
| 96 | 25VDD | - | Apply 2.5V (For internal core) |
| 97 | LDCUR(AD6) | I | |
| 98 | TDOFS(AD5) | I | |
| 99 | TG(AD4) | I | Tangential phase difference (FEP) |
| 100 | RFENV(AD3) | I | RF envelope input (FEP) |

■ AN8702FH (IC101) : Frontend processor

1. Pin layout

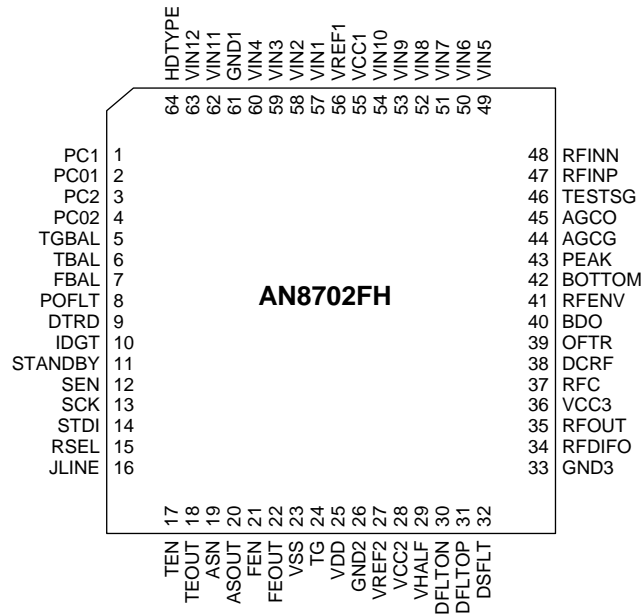

2. Pin function

| Pin No. | Symbol | I/O | Description | Pin No. | Symbol | I/O | Description |
|---------|---------|-----|---|---------|--------|-----|---|
| 1 | PC1 | I | Input for Laser current monitor | 34 | RFDIFO | O | RF operation output terminal |
| 2 | PC01 | O | Laser power control output for DVD | 35 | RFOUT | O | RF output terminal |
| 3 | PC2 | I | Photo detector fo CD | 36 | VCC3 | - | Power supply terminal 5V |
| 4 | PC02 | O | Laser power control output for CD | 37 | RFC | I | Filter for RF amplifier |
| 5 | TGBAL | I | Tangential phase balance control terminal | 38 | DCRF | O | All addition amplifier capacitor terminal |
| 6 | TBAL | I | Tracking balance control terminal | 39 | OFTR | O | OFTR output terminal |
| 7 | FBAL | I | Focus balance control terminal | 40 | BDO | O | BDO output terminal |
| 8 | POFLT | O | Track detection threshold level terminal | 41 | RFENV | O | RF envelope output terminal |
| 9 | DTRD | I | Data slice part data read signal input terminal (For RAM) | 42 | BOTTOM | O | Bottom envelope detection filter terminal |
| 10 | IDGT | I | Data slice part address part gate signal input terminal (For RAM) | 43 | PEAK | O | Peak envelope detection filter terminal |
| | | | | 44 | AGCG | O | AGC amplifier gain control terminal |
| | | | | 45 | AGCO | O | AGC amplifier level control terminal |
| 11 | STANDBY | I | Standby mode control terminal | 46 | TESTSG | I | TEST signal input terminal |
| 12 | SEN | I | SEN(Serial data input terminal) | 47 | RFINP | I | RF signal positive input terminal |
| 13 | SCK | I | SCK(Serial data input terminal) | 48 | RFINN | I | RF signal negative input terminal |
| 14 | STDI | I | STDI(Serial data input terminal) | 49 | VIN5 | I | RF input of external division into 4 terminal for CD |
| 15 | RSEL | I | DVD and CD selection | 50 | VIN6 | I | RF input of external division into 4 terminal for CD |
| 16 | JLINE | I | J-line setting output (FEP) | 51 | VIN7 | I | RF input of external division into 4 terminal for CD |
| 17 | TEN | I | Tracking error output amplifier reversing input terminal | 52 | VIN8 | I | RF input of external division into 4 terminal for CD |
| 18 | TEOUT | O | Tracking error signal output terminal | 53 | VIN9 | I | RF input of external division into 2 terminal for DVD |
| 19 | ASN | I | Off set adjustment terminal for DRC | 54 | VIN10 | I | RF input of external division into 2 terminal for DVD |
| 20 | ASOUT | O | All added signal output terminal | 55 | VCC1 | - | Power supply terminal 5V |
| 21 | FEN | I | Focus error output amplifier reversing input terminal | 56 | VREF1 | O | VREF1 voltage output terminal |
| 22 | FEOUT | O | Focus error signal output terminal | 57 | VIN1 | I | External division into four (DVD/CD) RF input terminal1 |
| 23 | VSS | - | Connect to GND | | | | |
| 24 | TG | O | Tangential phase error signal output terminal | | | | |
| 25 | VDD | - | Power supply terminal 3V | | | | |
| 26 | GND2 | - | Connect to GND | 59 | VIN3 | I | External division into four (DVD/CD) RF input terminal3 |
| 27 | VREF2 | O | VREF2 voltage output terminal | | | | |
| 28 | VCC2 | - | Power supply terminal 5V | | | | |
| 29 | VHALF | O | VHALF voltage output terminal | 60 | VIN4 | I | External division into four (DVD/CD) RF input terminal4 |
| 30 | DFLTON | O | Filter amplifier reversing output terminal | | | | |
| 31 | DFLTOP | O | Filter amplifier output terminal | | | | |
| 32 | DSFLT | O | Connected capacitor terminal for filter output | | | | |
| 33 | GND3 | - | Connect to GND | 61 | GND1 | - | Connect to GND |
| | | | | 62 | VIN11 | I | 3 beam sub input terminal for CD |
| | | | | 63 | VIN12 | I | 3 beam sub input terminal for CD |
| | | | | 64 | HDTYPE | I | HD type switching |

■ **BA3838F-X (IC560) : Stero A/D converter**

1. Pin layout



2. Block diagram

| Pin No. | Symbol | I/O | Function |
|---------|--------|-----|--|
| 1 | VCC | - | Power supply |
| 2 | MICIN | I | Microphone mixing input |
| 3 | LOUT | O | Channel L output |
| 4 | FK | I | Accepts signal from the key controller |
| 5 | TK | I | Output signal to the key controller |
| 6 | LIN | I | Channel L input |
| 7 | BIAS | I | Signal bias |
| 8 | GND | - | Connect to GND |
| 9 | RIN | I | Channel R input |
| 10 | LPF1 | I | Connects to LPF time constant element |
| 11 | LPF2 | I | Connects to LPF time constant element |
| 12 | LPF3 | O | LPF output |
| 13 | ROUT | O | Channel R output |
| 14 | CTRLA | I | Mode select input A |
| 15 | CTRLB | I | Mode select input B |
| 16 | CTRLC | I | Mode select input C |

■ **BU4094BCF (IC303) : Serial to parallel port extension**

1. Pin layout

| | | | |
|--------|---|----|---------------|
| STROBE | 1 | 16 | Vdd |
| DATA | 2 | 15 | OUTPUT ENABLE |
| CLOCK | 3 | 14 | Q5 |
| Q1 | 4 | 13 | Q6 |
| Q2 | 5 | 12 | Q7 |
| Q3 | 6 | 11 | Q8 |
| Q4 | 7 | 10 | Q's |
| Vss | 8 | 9 | Qs |

2. Block diagram

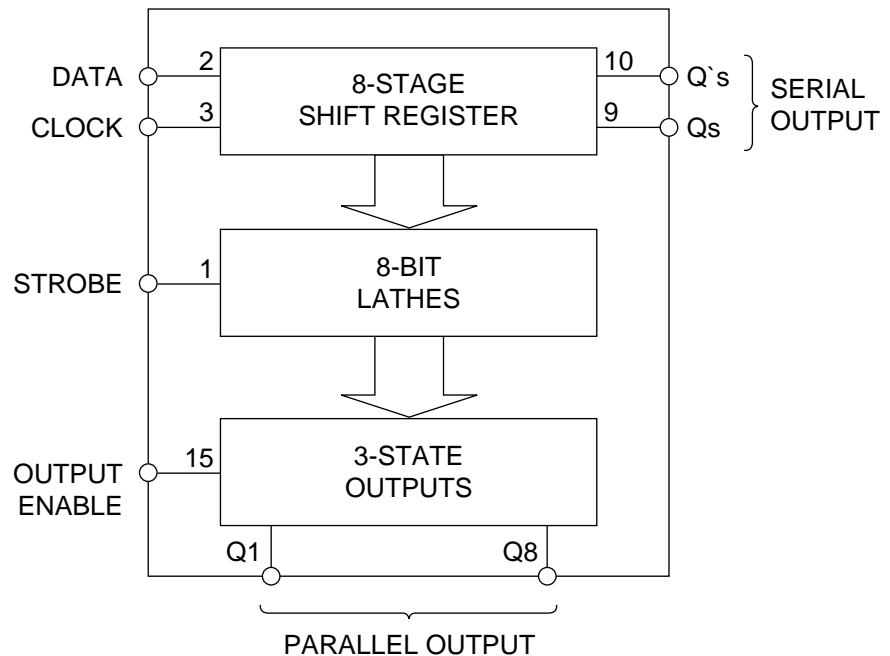

■ BA15218 (IC511~IC516, IC531~IC536) : Operation amplifier

1. Pin layout

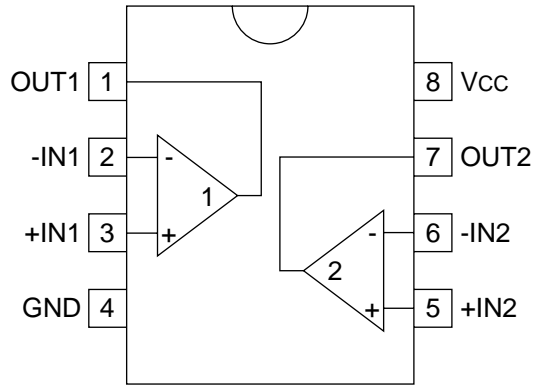

2. Block diagram

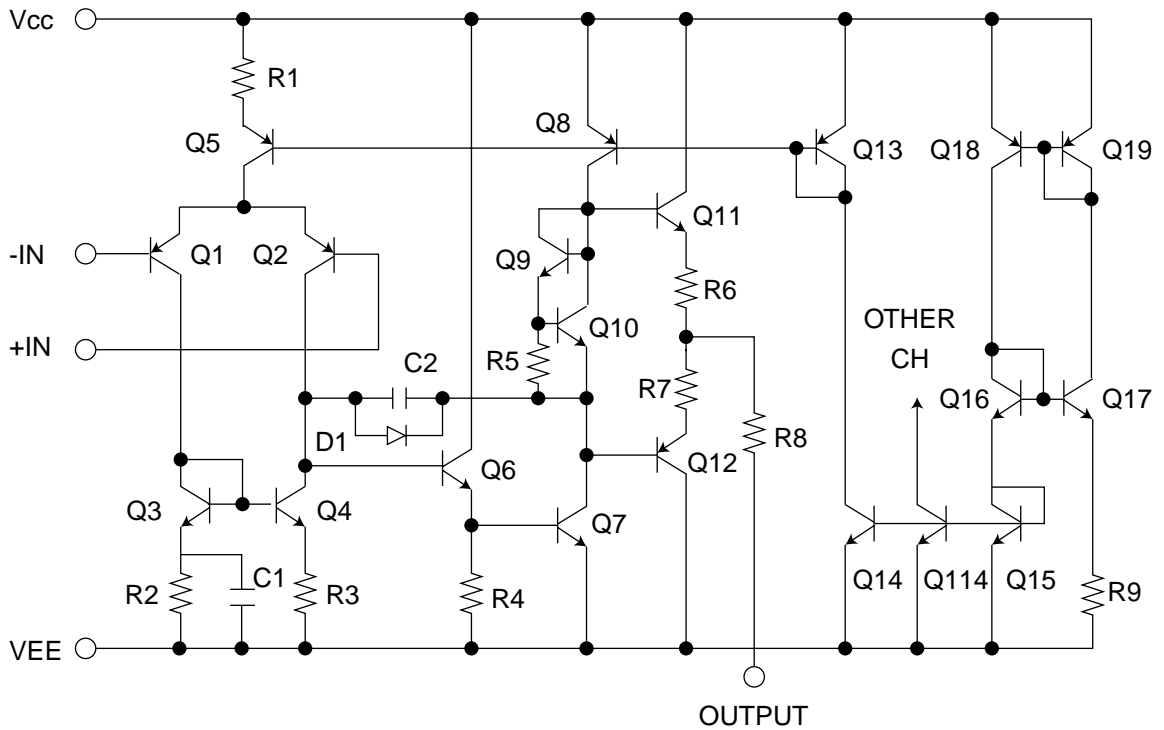

■ BA3126N (IC301) : R/P Switch

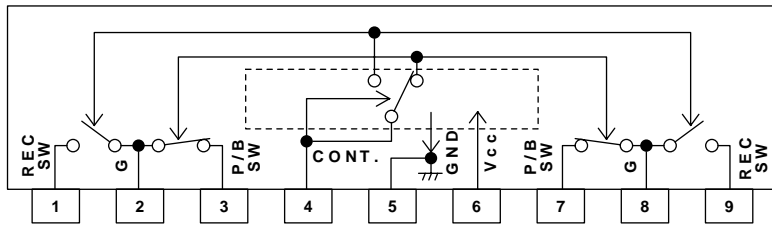

■ NAX0393-001 (IC502) : 27MHz Oscillator

1. Pin layout

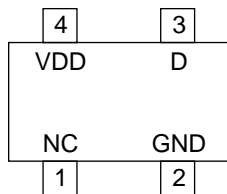

■ BU9253AS (IC902) : LPF / Echo Mix.

1. Pin layout / Block diagram

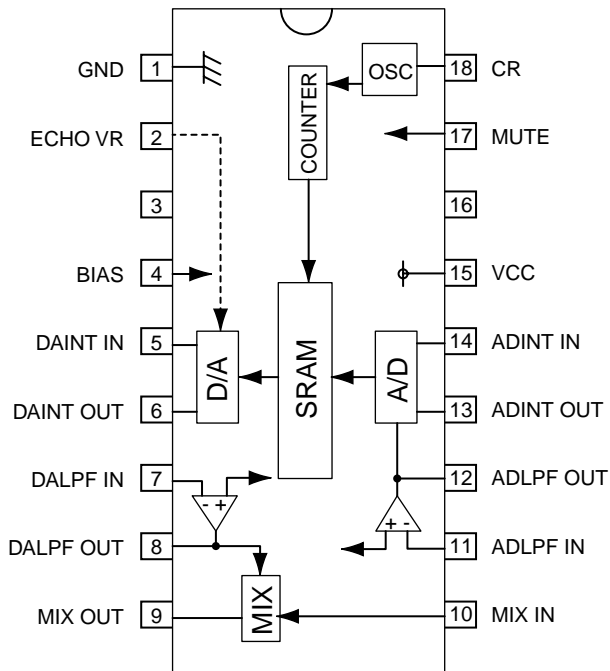

2. Pin function

| Pin No. | Symbol | I/O | Descriptions |
|---------|-----------|-----|---|
| 1 | GND | - | Connect GND |
| 2 | ECHO VR | I | Echo level control |
| 3 | | - | Non connect |
| 4 | BIAS | - | Analog part DC bias |
| 5 | DAINT IN | I | DA side integrator input |
| 6 | DAINT OUT | O | DA side integrator output |
| 7 | DALPF IN | I | DA side LPF input |
| 8 | DALPF OUT | O | DAside LPF output |
| 9 | MIX OUT | O | Mix AMP output for original tone& echo tone |
| 10 | MIX IN | I | Mix AMP input pin for original tone |
| 11 | ADLPF IN | I | AD side LPF input |
| 12 | ADLPF OUT | O | AD side LPF output |
| 13 | ADINT OUT | O | AD side integrator output |
| 14 | ADINT IN | I | AD side integrator input |
| 15 | VCC | - | Power supply |
| 16 | NC2 | - | Non connect |
| 17 | MUTE | I | Mute control signal input |
| 18 | CR | - | CR pin for oscillator |

■ KM416S1120DT-G8 (IC504, IC505) : 16M SDRAM

1. Pin layout

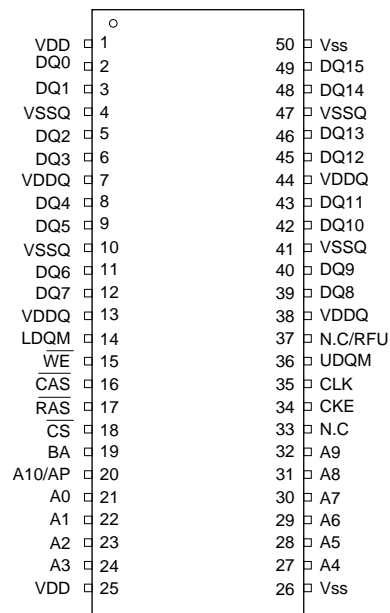

2. Pin function

| Pin No. | Symbol | I/O | Function | Pin No. | Symbol | I/O | Function |
|---------|--------|-----|------------------------|---------|--------|-----|------------------------|
| 1 | VCC | - | Power supply | 26 | VSS | - | Connect to GND |
| 2 | DQ0 | I/O | Data input/output | 27 | A4 | I | Address input |
| 3 | DQ1 | I/O | Data input/output | 28 | A5 | I | Address input |
| 4 | VSSQ | - | Connect to GND | 29 | A6 | I | Address input |
| 5 | DQ2 | I/O | Data input/output | 30 | A7 | I | Address input |
| 6 | DQ3 | I/O | Data input/output | 31 | A8 | I | Address input |
| 7 | VSSQ | - | Power supply | 32 | A9 | I | Address input |
| 8 | DQ4 | I/O | Data input/output | 33 | NC | - | No connect |
| 9 | DQ5 | I/O | Data input/output | 34 | CKE | I | Clock enable |
| 10 | VSSQ | - | Connect to GND | 35 | CLK | I | System clock input |
| 11 | DQ6 | I/O | Data input/output | 36 | UDQM | O | Data input/output mask |
| 12 | DQ7 | I/O | Data input/output | 37 | NC | - | No connect |
| 13 | VCCQ | - | Power supply | 38 | VCCQ | - | Power supply |
| 14 | LDQM | O | Data input/output mask | 39 | DQ8 | I/O | Data input/output |
| 15 | -WE | I | Write enable | 40 | DQ9 | I/O | Data input/output |
| 16 | -CAS | I | Column address strobe | 41 | VSSQ | - | Connect to GND |
| 17 | -RAS | I | Row address strobe | 42 | DQ10 | I/O | Data input/output |
| 18 | CS | I | Chip select | 43 | DQ11 | I/O | Data input/output |
| 19 | A11 | | Bank select address | 44 | VCCQ | - | Power supply |
| 20 | A10 | I | Address input | 45 | DQ12 | I/O | Data input/output |
| 21 | A0 | I | Address input | 46 | DQ13 | I/O | Data input/output |
| 22 | A1 | I | Address input | 47 | VSSQ | - | Connect to GND |
| 23 | A2 | I | Address input | 48 | DQ14 | I/O | Data input/output |
| 24 | A3 | I | Address input | 49 | DQ15 | I/O | Data input/output |
| 25 | VCC | - | Power supply | 50 | VSS | - | Connect to GND |

■ LA1838 (IC1) : FM AM IF Amp. & Detector, FM MPX Decoder

1. Block diagram

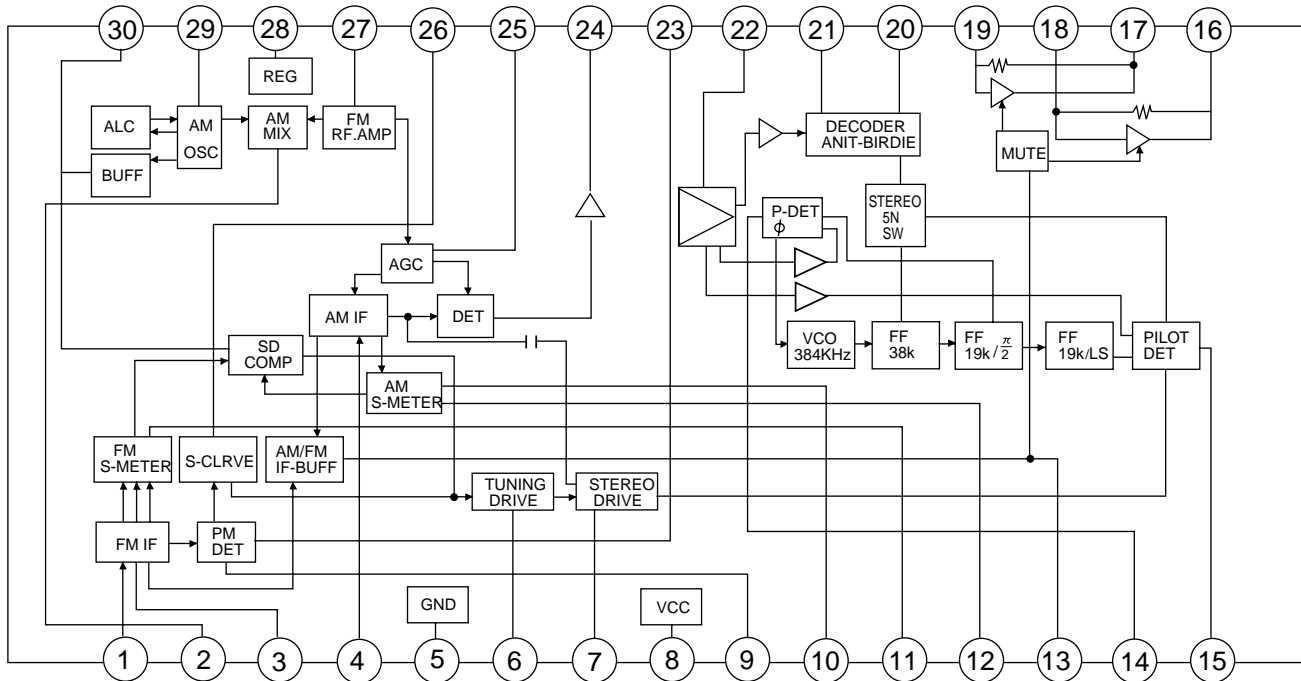

2. Pin function

| Pin No. | Symbol | I/O | Function | Pin No. | Symbol | I/O | Function |
|---------|---------|-----|---|---------|------------|-----|--|
| 1 | FM IN | I | This is an input terminal of FM IF signal. | 16 | L OUT | O | Left channel signal output. |
| 2 | AM MIX | O | This is an out put terminal for AM mixer. | 17 | R OUT | O | Right channel signal output. |
| 3 | FM IF | I | Bypass of FM IF | 18 | L IN | I | Input terminal of the Left channel post AMP. |
| 4 | AM IF | I | Input of AM IF Signal. | 19 | R IN | I | Input terminal of the Right channel post AMP. |
| 5 | GND | — | This is the device ground terminal. | 20 | RO | O | Mpx Right channel signal output. |
| 6 | TUNED | O | When the set is tuning, this terminal becomes "L". | 21 | LO | O | Mpx Left channel signal output. |
| 7 | STEREO | O | Stereo indicator output. Stereo "L", Mono: "H" | 22 | MPX IN | I | Mpx input terminal |
| 8 | VCC | — | This is the power supply terminal. | 23 | FM OUT | O | FM detection output. |
| 9 | FM DET | — | FM detect transformer. | 24 | AM DET | O | AM detection output. |
| 10 | AM SD | — | This is a terminal of AM ceramic filter. | 25 | AM AGC | I | This is an AGC voltage input terminal for AM |
| 11 | FM VSM | O | Adjust FM SD sensitivity. | 26 | AFC | — | This is an output terminal of voltage for FM-AFC. |
| 12 | AM VSM | O | Adjust AM SD sensitivity. | 27 | AM RF | I | AM RF signal input. |
| 13 | MUTE | I/O | When the signal of IF REQ of IC121(LC72131) appear, the signal of FM/AM IF output. //Muting control input. | 28 | REG | O | Register value between pin 26 and pin28 besides the frequency width of the input signal. |
| 14 | FM/AM | I | Change over the FM/AM input. "H" :FM, "L" : AM | 29 | AM OSC | — | This is a terminal of AM Local oscillation circuit. |
| 15 | MONO/ST | O | Stereo : "H", Mono: "L" | 30 | OSC BUFFER | O | AM Local oscillation Signal output. |

■ LC72136N (IC2) : PLL Frequency synthesizer

1. Pin layout

| | | | |
|-----------|----|----|--------|
| XT | 1 | 22 | XT |
| FM/AM | 2 | 21 | GND |
| CE | 3 | 20 | LPFOUT |
| DI | 4 | 19 | LPFIN |
| CLOCK | 5 | 18 | PD |
| DO | 6 | 17 | VCC |
| FM/ST/VCO | 7 | 16 | FMIN |
| AM/FM | 8 | 15 | AMIN |
| | 9 | 14 | |
| | 10 | 13 | IFCONT |
| SDIN | 11 | 12 | IFIN |

2. Block diagram

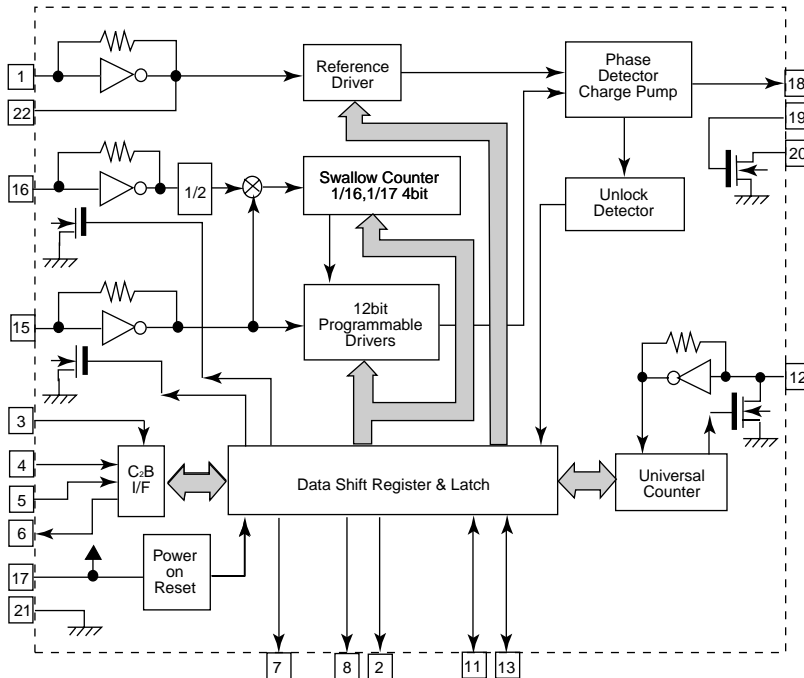

3. Pin function

| Pin No. | Symbol | I/O | Function | Pin No. | Symbol | I/O | Function |
|---------|-----------|-----|---|---------|--------|-----|---|
| 1 | XT | I | X'tal oscillator connect (75kHz) | 12 | IFIN | I | IF counter signal input |
| 2 | FM/AM | O | LOW:FM mode | 13 | IFCONT | O | IF signal output |
| 3 | CE | I | When data output / input for 4pin (input) and 6pin (output) : H | 14 | | - | Not use |
| 4 | DI | I | Input for receive the serial data from controller | 15 | AMIN | I | AM Local OSC signal output |
| 5 | CLOCK | I | Sync signal input use | 16 | FMIN | I | FM Local OSC signal input |
| 6 | DO | O | Data output for Controller Output port | 17 | VCC | - | Power sully (VDD=4.5-5.5V) When power ON: Reset circuit move |
| 7 | FM/ST/VCO | O | "Low": MW mode | 18 | PD | O | PLL charge pump output (H: Local OSC frequency Height than Reference frequency. L: Low Agreement: Height impedance) |
| 8 | AM/FM | O | Open state after the power on reset | 19 | LPFIN | I | Input for active low pass filter of PLL |
| 9 | LW | I/O | Input/output port | 20 | LPFOUT | O | Output for active low pass filter of PLL |
| 10 | MW | I/O | Input/output port | 21 | GND | - | Connected to GND |
| 11 | SDIN | I/O | Data input/output | 22 | XT | I | X'tal oscillator (75KHz) |

■ LC75342M-X (IC522, IC523) : E. volume

1. Pin layout

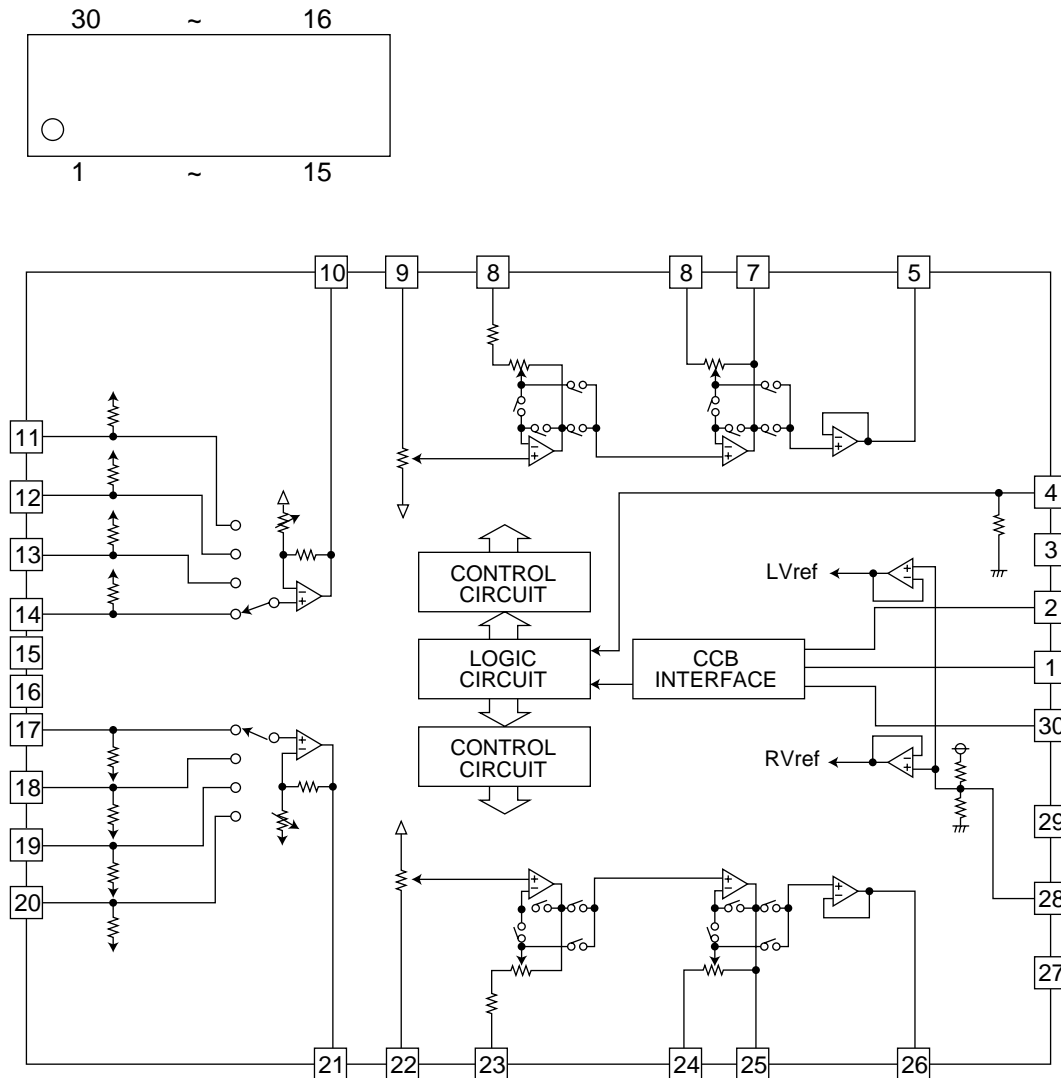

3. Pin function

| Pin No. | Symbol | Function | Pin No. | Symbol | Function |
|---------|--------|--|---------|--------|---|
| 1 | DI | Serial data and clock input for IC control | 17 | R1 | Input signal connections |
| 2 | CE | Chip enable | 18 | R2 | Input signal connections |
| 3 | VSS | Connect to GND | 19 | R3 | Input signal connections, not used |
| 4 | TEST | Electric volume connection for test | 20 | R4 | Not used |
| 5 | LOUT | Volume control and equalizer input | 21 | RSEL0 | Input selector output |
| 6 | LBASS2 | Connection for resistor and capacitor that from the bass band filter | 22 | RIN | Volume control and equalizer input |
| 7 | LBASS1 | | 23 | RTRE | Connection for capacitor that from the treble band filter |
| 8 | LTRE | Connection for capacitor that from the treble band filter | 24 | RBASS1 | Connection for resistor and capacitor that from the bass band filter |
| 9 | LIN | Volume control and equalizer input | 25 | RBASS2 | |
| 10 | LSEL0 | Input selector output | 26 | ROUT | Volume control and equalizer input |
| 11 | L4 | Not used | 27 | NC | Not used |
| 12 | L3 | Input signal connections, not used | 28 | VREF | Connection to the 0.5X VDD voltage generator circuit used as the analog signal ground |
| 13 | L2 | Input signal connections | 29 | VDD | Power supply |
| 14 | L1 | Input signal connections | 30 | CL | Serial data and clock input for IC control |
| 15 | NC | Connect to GND | | | |
| 16 | NC | Connect to GND | | | |

■ LC75345M-X (IC521) : Input selector

1. Pin layout

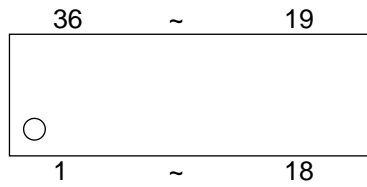

2. Block diagram

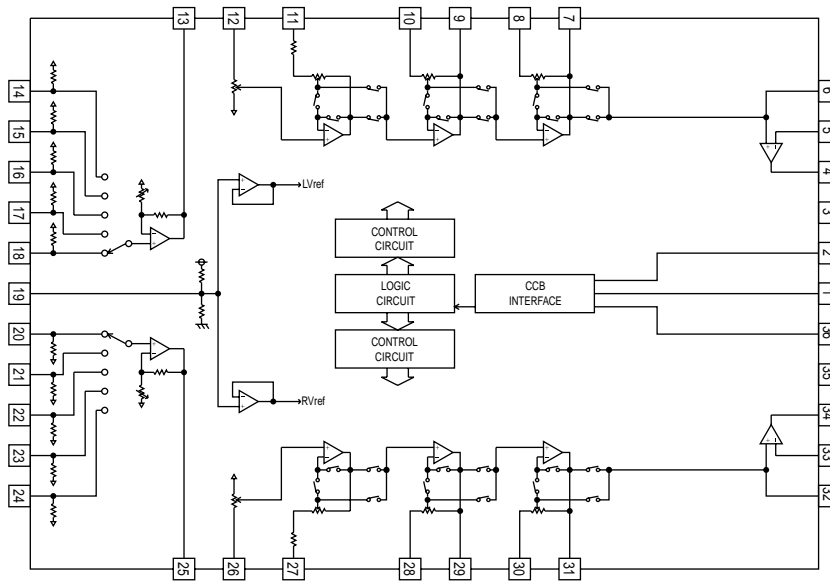

3. Pin function

| Pin No. | Symbol | Function | Pin No. | Symbol | Function |
|---------|--------|---|---------|--------|--|
| 1 | DI | Serial data input | 19 | VREF | 0.5 X VDD voltage generation block for analog ground |
| 2 | CE | Chip enable | 20 | DVDR | DVD Rch signal input pin |
| 3 | VSS | Connect to GND | 21 | PBR | Playback Rch signal input pin |
| 4 | LOPOUT | Output pin of genral purpose operation amplifier | 22 | TUR | Tuner Rch signal input pin |
| 5 | LINM | Non-invertd pin of general purpose operation amplifier | 23 | AUXR | Aux Rch signal input pin |
| 6 | NC | No connect | 24 | NC | No connect |
| 7 | LOUT | Att + equalizer output | 25 | RSELO | Input selector output pin |
| 8 | LSB | Capacitor and resistor connection pins comprising filters | 26 | RIN | Volume input |
| 9 | LBASS2 | for bass and super-bass band | 27 | RTRE | Capacitor connection pin comprising terble band filter |
| 10 | LBASS1 | Capacitor connection pin comprising treble band filter | 28 | RBASS1 | Capacitor and resistor connection pins comprising |
| 11 | LTRE | Capacitor connection pin comprising treble band filter | 29 | RBASS2 | filters for bass and superbass band |
| 12 | LIN | Volume input | 30 | RSB | Att + equalizer output |
| 13 | LSELO | Input selector output pin | 31 | ROUT | No connect |
| 14 | NC | No connect | 32 | NC | No connect |
| 15 | AUXL | Aux Lch signal input pin | 33 | RINM | Non-invertd pin of general purpose operation amplifier |
| 16 | TUL | Tuner Lch signal input pin | 34 | ROPOUT | Output pin of genral purpose operation amplifier |
| 17 | PBL | Playback Lch signal input pin | 35 | VDD | Power supply |
| 18 | DVDL | DVD Lch signal input pin | 36 | CL | Clock input |
| 19 | | 0.5 X VDD voltag generation block for analog ground | | | |

■ LV1100 (IC550) : Karaoke mic echo surround amp.

1. Pin layout

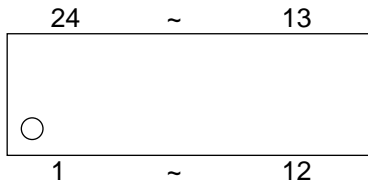

2. Block diagram

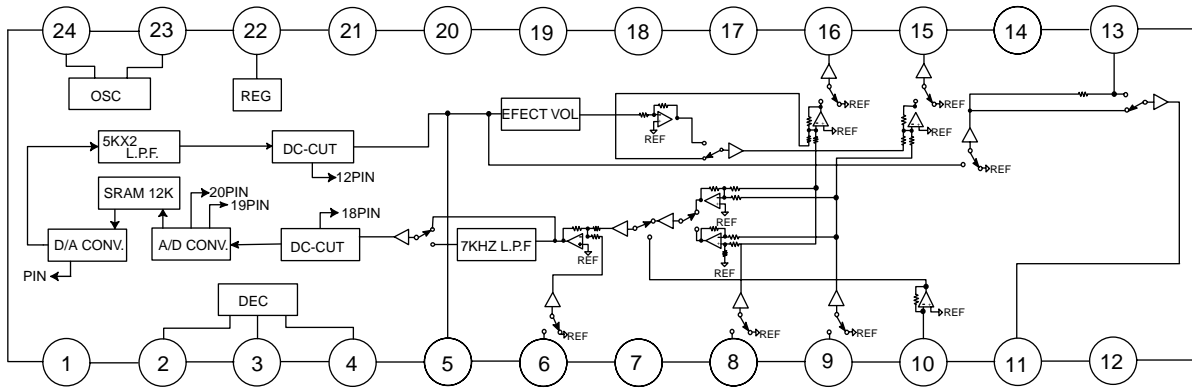

3. Pin function

| Pin No. | Symbol | I/O | Function |
|---------|---------|-----|---------------------------------------|
| 1 | VSS | - | Connect to GND |
| 2 | CLOCK | I | Clock for communicated data |
| 3 | DATA | I | Amp. control data |
| 4 | ENABLE | I | Control signal enable |
| 5 | REV-OUT | O | Reverse signal output |
| 6 | REV-IN | I | Reverse signal input |
| 7 | VCC | - | Power supply |
| 8 | IN-L | I | Analog signal input L |
| 9 | IN-R | I | Analog signal input R |
| 10 | IN-A | I | N.C. |
| 11 | OUT-A | O | N.C. |
| 12 | DC-OUT | O | DC-output |
| 13 | LPF | I | External terminal for low pass filter |
| 14 | VREF | I | Reference voltage |
| 15 | OUT-R | O | Analog signal output R |
| 16 | OUT-L | O | Analog signal output L |
| 17 | AGND | - | Connect to GND |
| 18 | DC-OUT | O | DC-output |
| 19 | A/D | I | External terminal for A/D |
| 20 | A/D | I | External terminal for A/D |
| 21 | D/A | I | External terminal for D/A |
| 22 | VDD | - | Power supply |
| 23 | X2 | O | External terminal for oscillator |
| 24 | X1 | I | External terminal for oscillator |

M56788FP-M (IC271) : Traverse mechanism driver

1. Pin layout

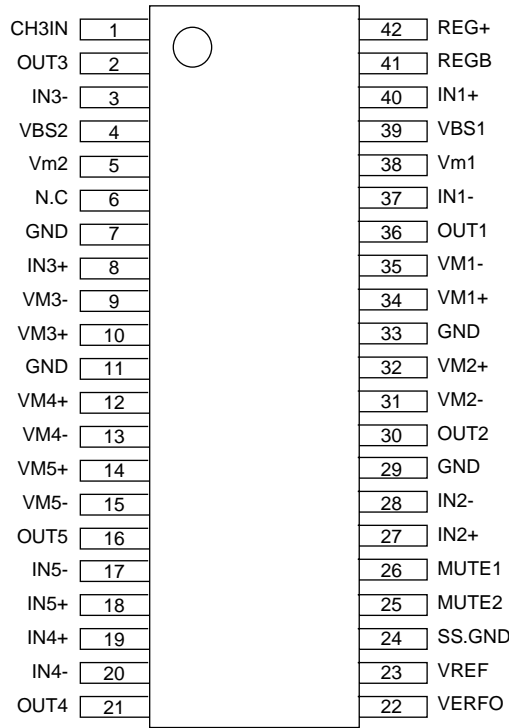

2. Block diagram

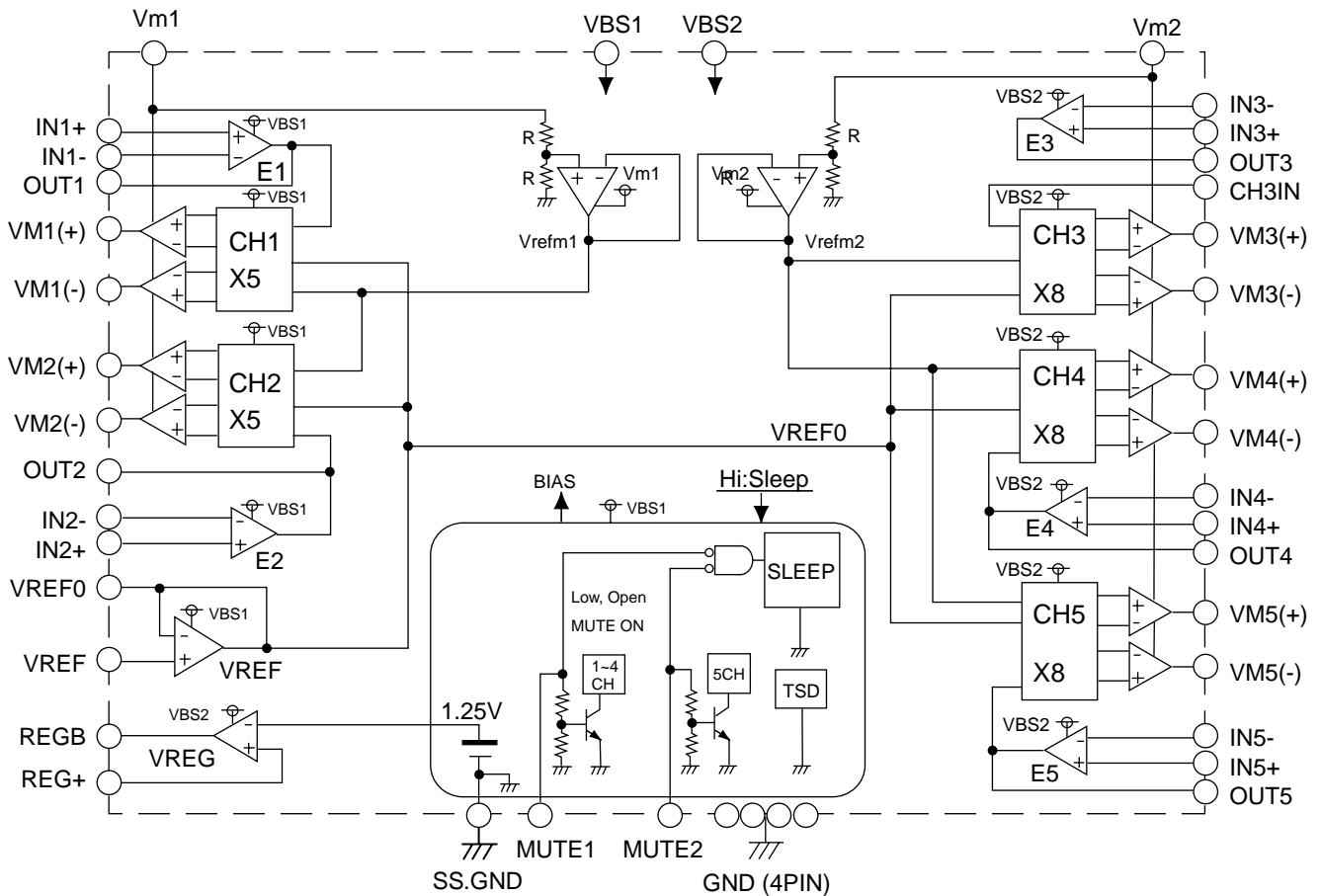

■ MN102L62GEJ (IC401) : Unit CPU

1. Pin layout

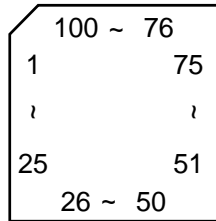

2. Pin function

| Pin No. | Symbol | I/O | Function | Pin No. | Symbol | I/O | Function |
|---------|---------|-----|-------------------------------------|---------|---------|-----|--------------------------------|
| 1 | WAIT | I | Micon wait signal input | 51 | FGIN | | |
| 2 | RE | O | Read enable | 52 | TRS | | |
| 3 | SPMUTE | O | Spindle muting outout to IC251 | 53 | ADSCEN | O | Serial enable signal for ADSC |
| 4 | WEN | O | Write enable | 54 | VDD | - | Power er supplyo |
| 5 | CS0 | - | Non connect | 55 | FEPEN | O | Serial enabial signal for FEP |
| 6 | CS1 | O | Chip select for ODC | 56 | SLEEP | O | Standby signal for FEP |
| 7 | CS2 | O | Chip select for ZIVA | 57 | BUSY | I | Communication busy |
| 8 | CS3 | O | Chip select for outer ROM | 58 | REQ | O | Communication Request |
| 9 | DRVMUTE | O | Driver mute | 59 | CIRCEN | O | CIRC command select |
| 10 | SPKICK | O | Spin kick (Non connect) | 60 | HSSEEK | - | Non connect |
| 11 | LSIRST | O | LSI reset | 61 | VSS | - | Ground |
| 12 | WORD | O | Bus selection input | 62 | EPCS | O | EEPROM chip select |
| 13 | A0 | O | Address bus 0 for CPU | 63 | EPSK | O | EEPROM clock |
| 14 | A1 | O | Address bus 1 for CPU | 64 | DPDI | I | EEPROM data input |
| 15 | A2 | O | Address bus 2 for CPU | 65 | EPDO | O | EEPROM data output |
| 16 | A3 | O | Address bus 3 for CPU | 66 | VDD | - | Power supply |
| 17 | VDD | - | Power supply | 67 | SCLKO | I | Communication clock |
| 18 | SYSCLK | O | System clock signal output | 68 | S2UDT | I | Communication input data |
| 19 | VSS | - | Ground | 69 | U2SDT | O | Communication output data |
| 20 | XI | - | Not use (Connect to vss) | 70 | CPSCK | O | Clock for ADSC serial |
| 21 | XO | - | Non connect | 71 | SDIN | I | ADSC serial data input |
| 22 | VDD | - | Power supply | 72 | SDOUT | O | ADSC serial data output |
| 23 | OSCI | I | Clock signal input(13.5MHz) | 73 | - | - | Not use |
| 24 | OSCO | O | Clock signal output(13.5MHz) | 74 | - | - | Not use |
| 25 | MODE | I | CPU Mode selection input | 75 | NMI | - | Not use |
| 26 | A4 | O | Address bus 4 for CPU | 76 | ADSCIRQ | I | Interrupt input of ADSC |
| 27 | A5 | O | Address bus 5 for CPU | 77 | ODCIRQ | I | Interrupt input of ODC |
| 28 | A6 | O | Address bus 6 for CPU | 78 | DECIRQ | I | Interrupt input of ZIVA |
| 29 | A7 | O | Address bus 7 for CPU | 79 | WAKEUP | O | Not use |
| 30 | A8 | O | Address bus 8 for CPU | 80 | ODCIRQ2 | I | Interruption of system control |
| 31 | A9 | O | Address bus 9 for CPU | 81 | ADSEP | I | Address data selection input |
| 32 | A10 | O | Address bus 10 for CPU | 82 | RST | I | Reset input |
| 33 | A11 | O | Address bus 11 for CPU | 83 | VDD | - | Power supply |
| 34 | VDD | - | Power supply | 84 | TEST1 | I | Test signal 1 input |
| 35 | A12 | O | Address bus 12 for CPU | 85 | TEST2 | I | Test signal 2 input |
| 36 | A13 | O | Address bus 13 for CPU | 86 | TEST3 | I | Test signal 3 input |
| 37 | A14 | O | Address bus 14 for CPU | 87 | TEST4 | I | Test signal 4 input |
| 38 | A15 | O | Address bus 15 for CPU | 88 | TEST5 | I | Test signal 5 input |
| 39 | A16 | O | Address bus 16 for CPU | 89 | TEST6 | I | Test signal 6 input |
| 40 | A17 | O | Address bus 17 for CPU | 90 | TEST7 | I | Test signal 7 input |
| 41 | A18 | O | Address bus 18 for CPU | 91 | TEST8 | I | Test signal 8 input |
| 42 | A19 | O | Address bus 19 for CPU | 92 | VSS | - | Ground |
| 43 | VSS | - | Ground | 93 | D0 | I/O | Data bus 0 of CPU |
| 44 | A20 | O | Address bus 20 for CPU | 94 | D1 | I/O | Data bus 1 of CPU |
| 45 | TXSEL | O | TX Select | 95 | D2 | I/O | Data bus 2 of CPU |
| 46 | HAGUP | O | | 96 | D3 | I/O | Data bus 3 of CPU |
| 47 | CD/DVD | O | Foucs balance & leaser power select | 97 | D4 | I/O | Data bus 4 of CPU |
| 48 | ADPD | O | Power up out put | 98 | D5 | I/O | Data bus 5 of CPU |
| 49 | HMFON | O | | 99 | D6 | I/O | Data bus 6 of CPU |
| 50 | TRVSW | I | Detection switch of traverse inside | 100 | D7 | I/O | Data bus 7 of CPU |

MM3023DN-X (IC1, IC102) : Switching regulator

1. Pin layout

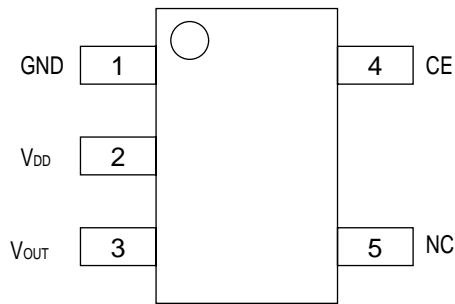

1. Block diagram

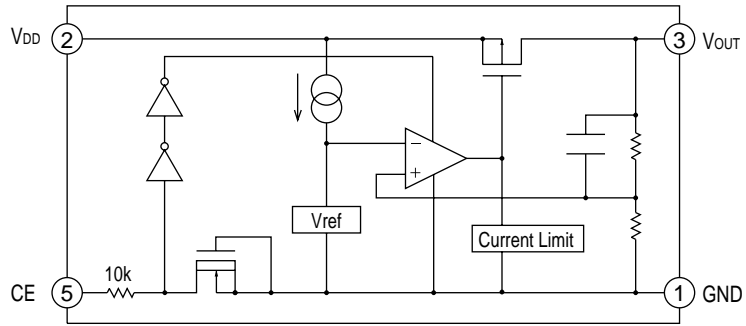

3. Pin function

| Pin No. | Symbol | I/O | Function |
|---------|--------|-----|-------------------------------|
| 1 | GND | - | Connect to GND |
| 2 | VDD | - | Power supply |
| 3 | VOUT | O | Regulator output |
| 4 | NC | - | No connect |
| 5 | CE | I | Output voltage on/off control |

BR93LC66F-X (IC403) : EEPROM

1. Pin layout

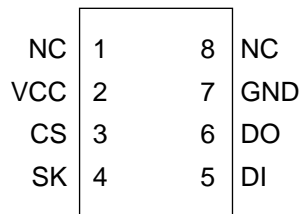

2.Pin Functions

| Symbol | I/O | Function |
|--------|-----|--|
| VCC | - | Power supply |
| GND | - | Connect to GND |
| CS | I | Chip select input |
| SK | I | Serial clock input |
| DI | I | Start bit, OP-code, address, serial data input |
| DO | O | Serial data output, Internal state display output of READY/BUSY |

2. Block diagram

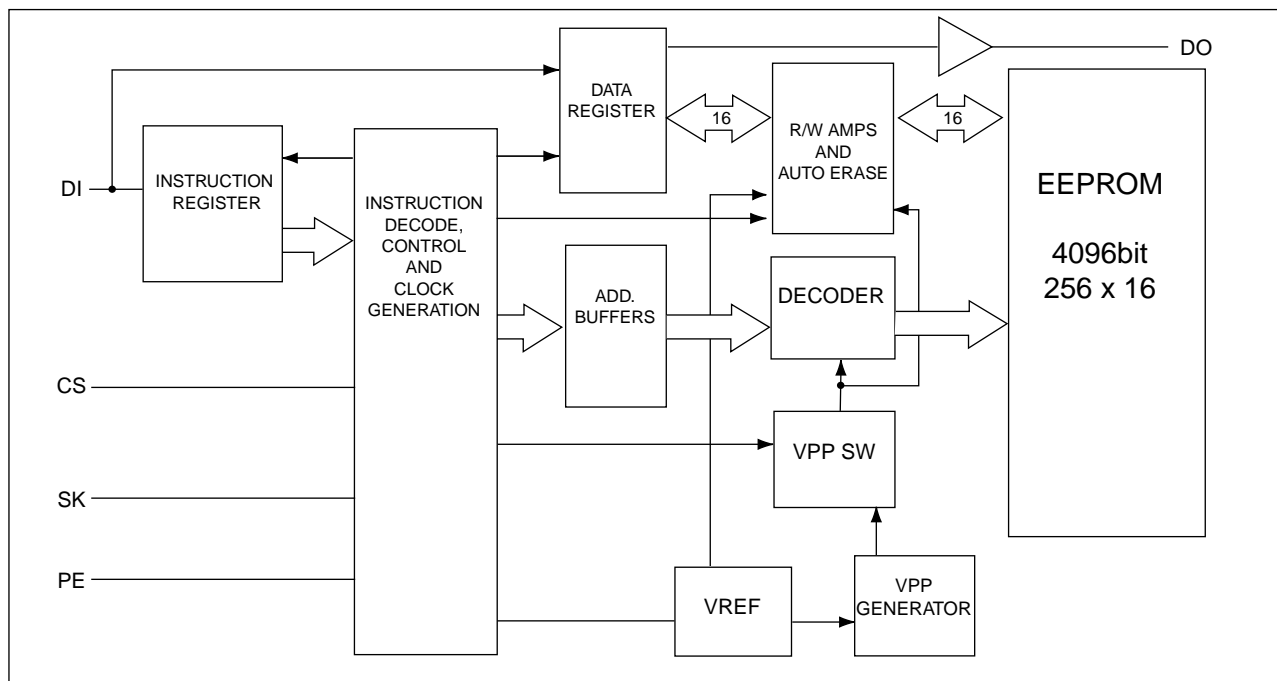

■ MN35505 (IC501, IC502, IC503) : DAC

1. Pin layout



2. Pin function

| Pin No. | Symbol | I/O | Function |
|---------|--------|-----|--------------------------|
| 1 | M5 | I | Control signal for DAC |
| 2 | DIN | I | Digital data input |
| 3 | LRCK | I | L and R clock for DAC |
| 4 | BCK | I | Bit clock for DAC |
| 5 | M3 | I | Control signal for DAC |
| 6 | DVDD2 | - | Power supply |
| 7 | CKO | - | No connect |
| 8 | DVSS2 | - | Connect to GND |
| 9 | M2 | I | Control signal for DAC |
| 10 | M1 | I | Control signal for DAC |
| 11 | OUT1C | O | Analog output 1 |
| 12 | AVDD1 | - | Power supply |
| 13 | OUT1D | O | Analog output 1 |
| 14 | AVSS1 | - | Connect to GND |
| 15 | AVSS2 | - | Connect to GND |
| 16 | OUT2D | O | Analog output 2 |
| 17 | AVDD2 | - | Power supply |
| 18 | OUT2C | O | Analog output 2 |
| 19 | M9 | I | Control signal for DAC |
| 20 | DVSS2 | - | Connect to GND |
| 21 | XOUT | - | No connect |
| 22 | XIN | - | No connect |
| 23 | VCOF | I | VCO frequency |
| 24 | DVDD1 | - | Power supply D+5V |
| 25 | M7 | - | Connect to GND |
| 26 | M8 | - | Connect to GND |
| 27 | M4 | I | Control signal for DAC |
| 28 | M6 | I | Clock for control signal |

■ MR27V1602EM (IC402) : 16M ROM

1. Pin layout

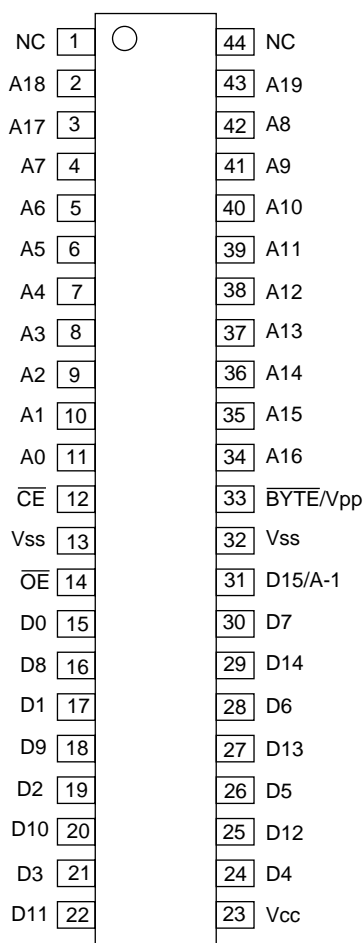

2. Pin function

| Pin No. | Symbol | I/O | Function | Pin No. | Symbol | I/O | Function |
|---------|--------|-----|----------------|---------|----------|-----|---------------------------|
| 1 | NC | | | 23 | Vcc | - | Power supply |
| 2 | A18 | I | Address input | 24 | D4 | O | Data output |
| 3 | A17 | I | Address input | 25 | D12 | O | Data output |
| 4 | A7 | I | Address input | 26 | D5 | O | Data output |
| 5 | A6 | I | Address input | 27 | D13 | O | Data output |
| 6 | A5 | I | Address input | 28 | D6 | O | Data output |
| 7 | A4 | I | Address input | 29 | D14 | O | Data output |
| 8 | A3 | I | Address input | 30 | D7 | O | Data output |
| 9 | A2 | I | Address input | 31 | D15/A-1 | I/O | Data output/address input |
| 10 | A1 | I | Address input | 32 | Vss | - | Connect to GND |
| 11 | A0 | I | Address input | 33 | BYTE/Vpp | I | Mode switch |
| 12 | CE | I | Chip enable | 34 | A16 | I | Address input |
| 13 | Vss | - | Connect to GND | 35 | A15 | I | Address input |
| 14 | OE | O | Output enable | 36 | A14 | I | Address input |
| 15 | D0 | O | Data output | 37 | A13 | I | Address input |
| 16 | D8 | O | Data output | 38 | A12 | I | Address input |
| 17 | D1 | O | Data output | 39 | A11 | I | Address input |
| 18 | D9 | O | Data output | 40 | A10 | I | Address input |
| 19 | D2 | O | Data output | 41 | A9 | I | Address input |
| 20 | D10 | O | Data output | 42 | A8 | I | Address input |
| 21 | D3 | O | Data output | 43 | A19 | I | Address input |
| 22 | D11 | O | Data output | 44 | NC | | |

■ STK412-090 (IC701) : Operation amplifier

1. Pin layout

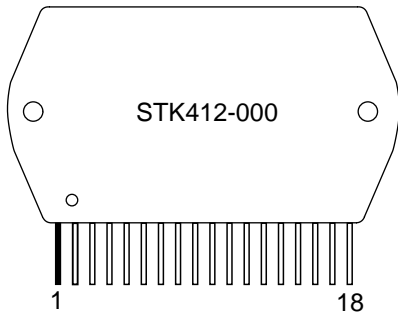

2. Block diagram

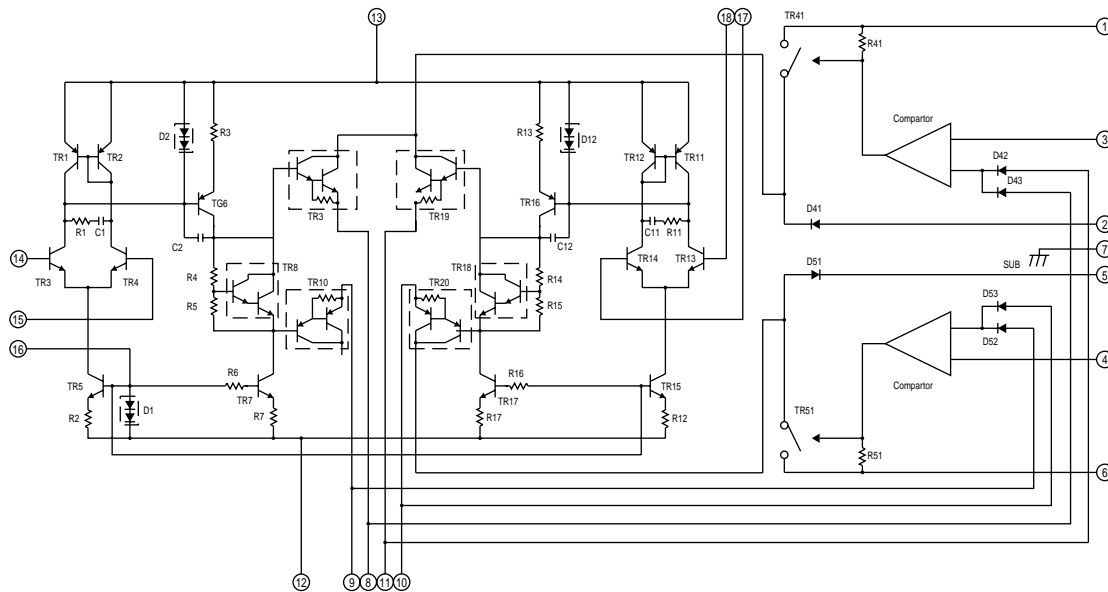

■ STK402-040 (IC752) : Operation amplifier

1. Pin layout

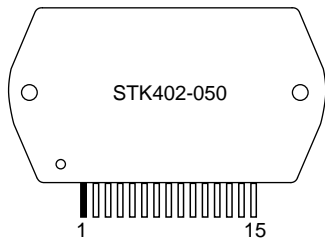

2. Block diagram

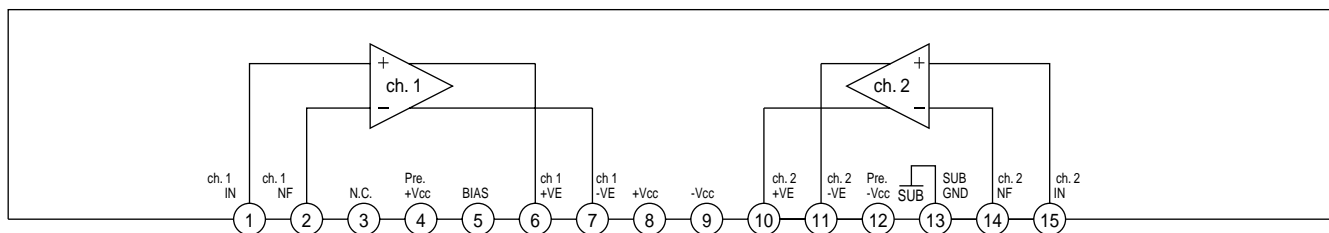

■ **TC7SH08FU-X (IC311, 312) : Timing control**

1.Pin layout

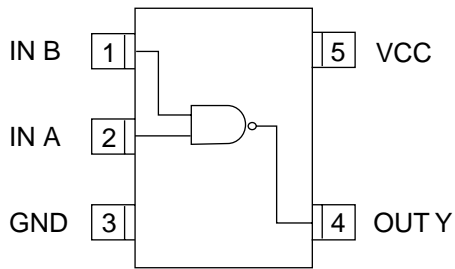

■ **TA8409S (IC802, 803) : Motor driver**

1. Pin layout

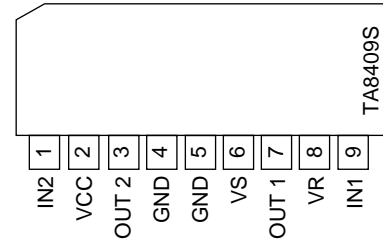

2. Pin function

| INPUT | | OUTPUT | | MODE |
|-------|-----|--------|------|--------|
| IN1 | IN2 | OUT1 | OUT2 | MOTOR |
| 0 | 0 | ∞ | ∞ | STOP |
| 1 | 0 | H | L | CW/CCW |
| 0 | 1 | L | H | CCW/CW |
| 1 | 1 | L | L | BRAKE |

■ **TC74VHC00FT-X (IC322,IC503) : Write timing control**

1. Pin layout / Block diagram

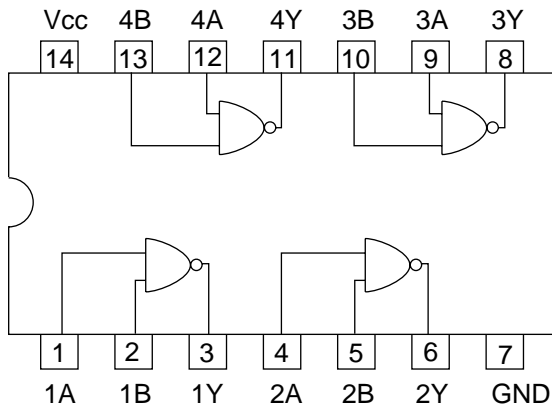

■ **TC74VHC125FT (IC411) : Buffer**

1. Pin layout / Block diagram

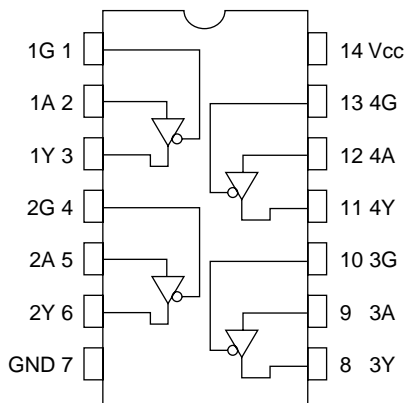

2. Truth table

| INPUTS | | OUTPUTS |
|-----------|---|---------|
| \bar{G} | A | Y |
| H | X | Z |
| L | L | L |
| L | H | H |

X: Don't care
Z: High impedance

■ **TC7WH74FU-X (IC321) : Clock buffer**

1. Pin layout

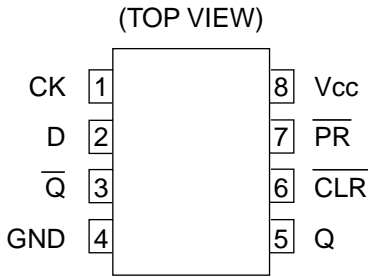

2. Block diagram

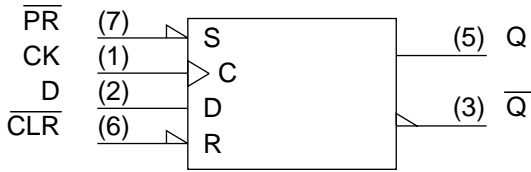

■ **TC7W125FU-X (IC412) : Buffer**

1. Pin layout

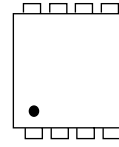

2. Block diagram

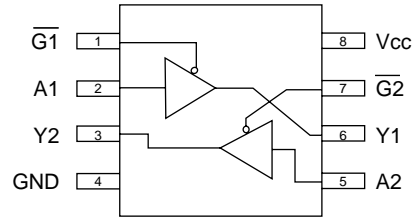

■ **STK402-230 (IC321) : Power amp**

1. Pin layout

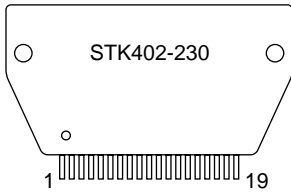

2. Block diagram

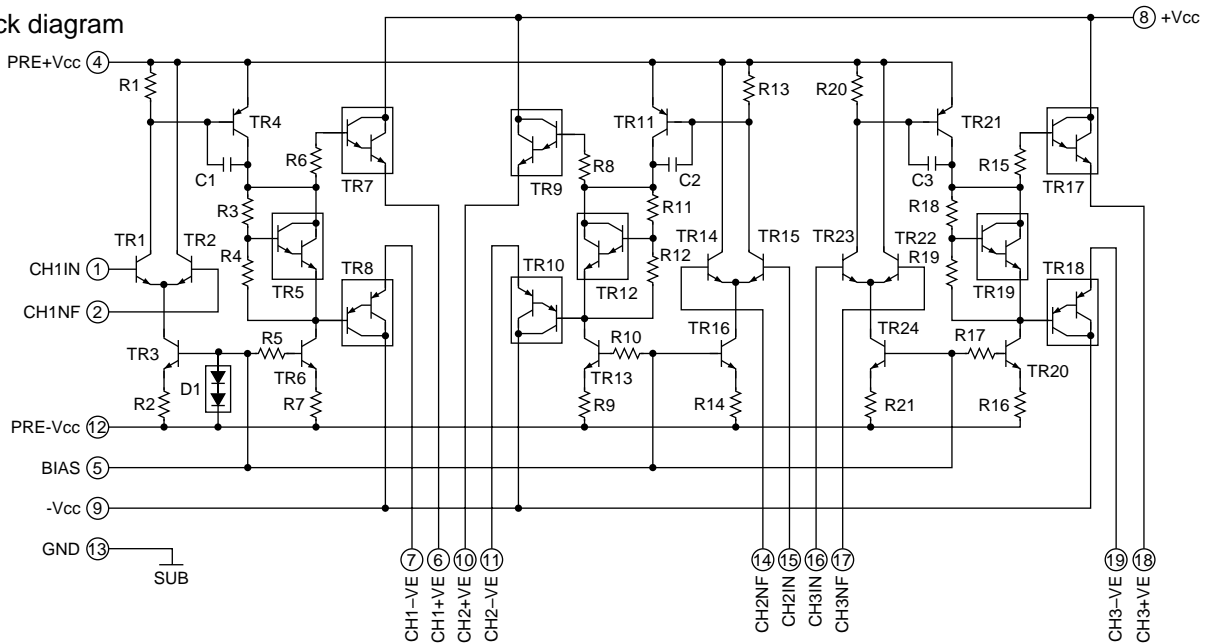

< MEMO >

MX-DVB10

JVC

VICTOR COMPANY OF JAPAN, LIMITED

AUDIO & COMMUNICATION BUSINESS DIVISION

PERSONAL & MOBILE NETWORK BUSINESS UNIT. 10-1,1chome,Ohwatari-machi,Maebashi-city,371-8543,Japan

(No.21120)

 Printed in Japan
200209

PARTS LIST

[MX-DVB10]

* All printed circuit boards and its assemblies are not available as service parts.

| Area suffix | |
|-------------|--------------|
| US ----- | Singapore |
| UX ----- | Saudi Arabia |
| UN ----- | Asean |

- Contents -

Exploded view of general assembly and parts list (Block No.M1) ----- 3- 3

Speaker assembly and parts list SP-XDVB10 (Block No.M7) ----- 3- 6

Speaker assembly and parts list SP-WDVB10 (Block No.M8)----- 3- 7

DVD mechanism assembly and parts list (Block No.MJ) ----- 3- 8

DVD changer mechanism assembly and parts list (Block No.MK) ----- 3-10

Cassette mechanism assembly and parts list (Block No.MP) ----- 3-12

Electrical parts list (Block No.01~10) ----- 3-16

Packing materials and accessories parts list (Block No.M3,M5) ----- 3-37

< M E M O >

Exploded view of general assembly and parts list

Block No. **M 1 M M**

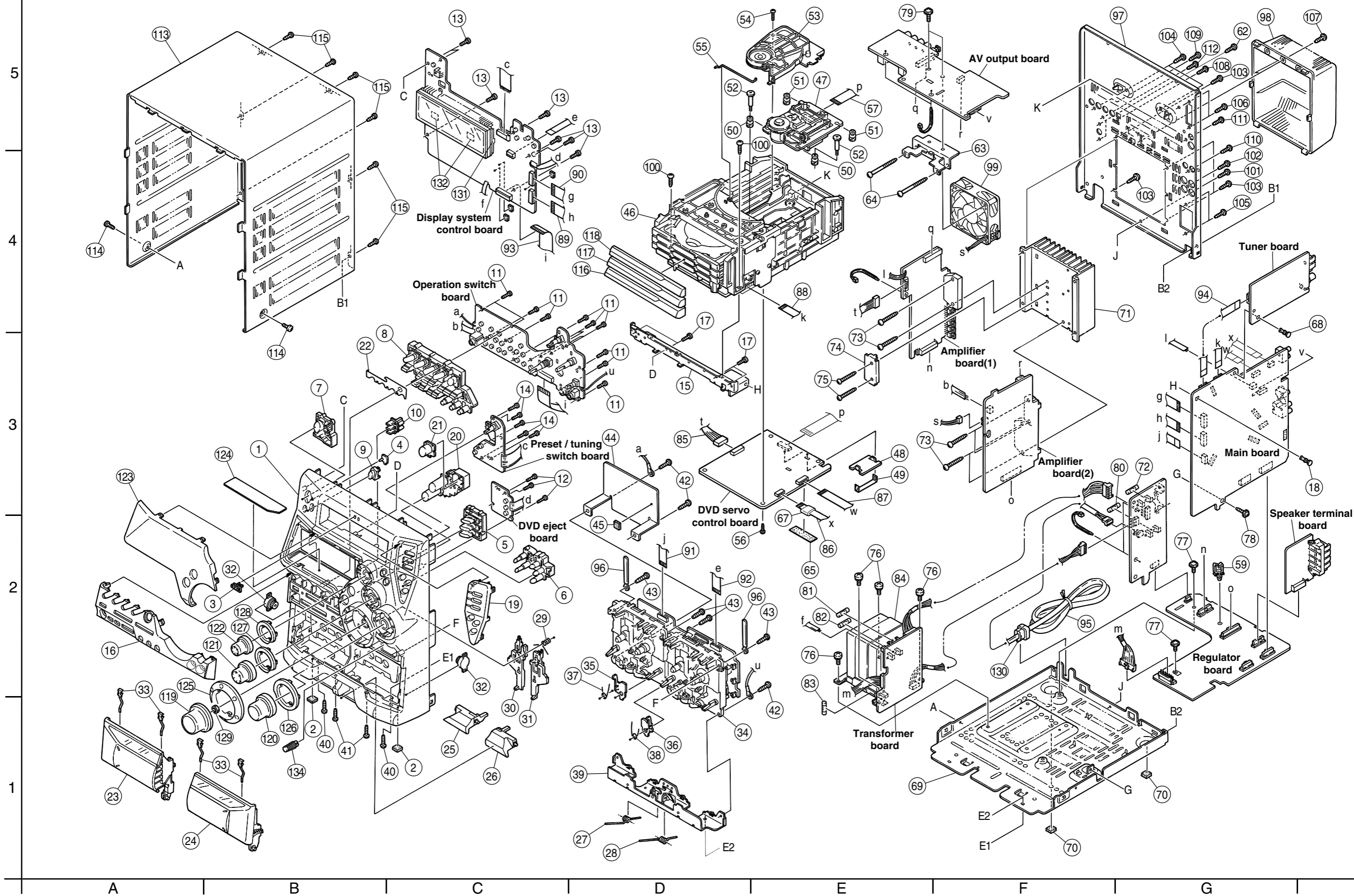

■ Parts list (General assembly)

Block No. M1MM

| △ | Item | Parts number | Parts name | Q'ty | Description | Area |
|---|------|--------------|-----------------|------|-----------------|------|
| | 1 | GV10057-007A | FRONT PANEL | 1 | | |
| | 2 | GV40246-001A | FOOT SPACER | 2 | | |
| | 3 | GV40077-002A | JVC BADGE | 1 | | |
| | 4 | GV40136-001A | STANDBY INDICAT | 1 | | |
| | 5 | GV30154-004A | CD BUTTON | 1 | | |
| | 6 | GV20104-002A | CD EJECT BUTTON | 1 | | |
| | 7 | GV30137-001A | POWER BUTTON | 1 | | |
| | 8 | GV30177-008A | CONTROL BUTTON | 1 | | |
| | 9 | GV30139-001A | REMOTE LENS | 1 | | |
| | 10 | GV30140-002A | DVD INDICATOR | 1 | | |
| | 11 | QYSDSF2608Z | SCREW | 12 | ON VOLUME BRD. | |
| | 12 | QYSDSF2608Z | SCREW | 3 | ON CD BRD. | |
| | 13 | QYSDSF2608Z | SCREW | 7 | ON MICOM BRD. | |
| | 14 | QYSDSF2608Z | SCREW | 5 | ON SOURCE BRD. | |
| | 15 | GV30129-001A | STAY BRACKET | 1 | | |
| | 16 | GV10060-011A | ORNAMENT | 1 | | |
| | 17 | QYSDSF2608Z | SCREW | 4 | STY.BRKT.+F.PNL | |
| | 18 | E310243-002 | PLASTIC RIVET | 1 | M.BRD.+ STY BRK | |
| | 19 | GV20103-003A | SUB PANEL | 1 | | |
| | 20 | GV30138-001A | FRONT BUTTON | 1 | | |
| | 21 | GV40144-001A | DVD LENS | 1 | | |
| | 22 | GV40185-002A | COVER SHEET | 1 | | |
| | 23 | GV30211-005A | C.HOLD.ASSY(L) | 1 | | |
| | 24 | GV30212-005A | C.HOLD.ASSY(R) | 1 | | |
| | 25 | GV20099-002A | EJECT BUTTON A | 1 | | |
| | 26 | GV20100-002A | EJECT BUTTON B | 1 | | |
| | 27 | FMKW4009-002 | HOLDER SPRING A | 1 | | |
| | 28 | FMKW4010-002 | HOLDER SPRING B | 1 | | |
| | 29 | FMKW4011-001 | SPRING | 1 | FOR EJECT LEVER | |
| | 30 | FMKS3002-003 | EJECT LEVER(A) | 1 | | |
| | 31 | FMKS3003-003 | EJECT LEVER(B) | 1 | | |
| | 32 | GV40034-001A | DAMPER ASSY | 2 | | |
| | 33 | VKY4180-401 | CASSETTE SPRING | 4 | | |
| | 34 | ----- | CASSETTE MECHA | 1 | | |
| | 35 | FMKL4012-004 | EJECT SAFETY(A) | 1 | | |
| | 36 | FMKL4013-001 | EJECT SAFETY(B) | 1 | | |
| | 37 | FMKW4007-001 | SPRING (A) | 1 | EJECT SAFETY A | |
| | 38 | FMKW4008-001 | SPRING (B) | 1 | EJECT SAFETY B | |
| | 39 | GV20094-001A | HOLDER BRACKET | 1 | | |
| | 40 | QYSBSG3010Z | T.SCREW | 2 | F.P.TO H.BRKT. | |
| | 41 | QYSBSG3010Z | T.SCREW | 2 | F.P.TO CHS.BASE | |
| | 42 | QYSBSG3010Z | T.SCREW | 3 | MECHA & H.BRKT. | |
| | 43 | QYSBSF3012Z | SCREW | 4 | MECHA & F.PANEL | |
| | 44 | GV30124-001A | TRANS SHIELD | 1 | | |
| | 45 | E3400-431 | SPACER | 1 | STICK AT SLC MO | |
| | 46 | ----- | DVD CHANGER MEC | 1 | | |
| | 47 | ----- | DVD MECHA | 1 | | |
| | 48 | LV41362-001A | HEAT SINK | 1 | | |

■ Parts list (General assembly)

Block No. M1MM

| △ | Item | Parts number | Parts name | Q'ty | Description | Area |
|---|------|----------------|-----------------|------|-----------------|-------|
| | 49 | LV41363-002A | HOLDER | 1 | | |
| | 50 | LV41120-003A | INSULATOR | 2 | FRONT ONLY | |
| | 51 | LV41120-004A | INSULATOR | 2 | REAR ONLY | |
| | 52 | LV41119-001A | SPECIAL SCREW | 2 | FRONT ONLY | |
| | 53 | VKS3703-00K | CLAMPER ASSY | 1 | | |
| | 54 | QYSPST2606Z | SCREW | 1 | CLAMP ASSY | |
| | 55 | VKW5187-001 | ROD | 1 | | |
| | 56 | QYSBSF3008Z | SCREW | 1 | MODULE CB | |
| | 57 | QUQ105-4010AJ | FFC WIRE | 1 | FW101 | |
| | 59 | GV40236-001A | PLASTIC HOLDER | 1 | STICK AT FMH BO | |
| | 62 | QYSBSF3012E | SPECIAL SCREW | 2 | VOLT SEL/R.PNL | |
| | 63 | GV40189-001A | FAN BRACKET | 1 | | |
| | 64 | QYSBSG3035Z | T.SCREW | 2 | FAN TO FAN BRAC | |
| | 65 | VYSA1R3-003 | SPACER | 1 | AT FERRITE CORE | |
| | 67 | QQR1259-002 | FERRITE CORE | 1 | | |
| | 68 | E310243-002 | PLASTIC RIVET | 1 | TUNER BRD.+ FMC | |
| | 69 | GV10061-001A | CHASSIS BASE | 1 | | |
| | 70 | GV40246-002A | FOOT SPACER | 2 | CHASS BASE FOOT | |
| | 71 | GV30191-001A | HEAT SINK | 1 | | |
| △ | 72 | QMF51W2-2R0-J8 | FUSE | 1 | F003 | |
| | 73 | QYSBSG3014E | T.SCREW | 6 | FOR POWER IC | |
| | 74 | GV40143-001A | LEAP SPRING | 1 | | |
| | 75 | QYSBSG3014E | T.SCREW | 2 | FOR LEAF SPRING | |
| | 76 | QYSDSTL4008Z | SPECIAL SCREW | 4 | FOR TRANS/CH.BS | |
| | 77 | QYSBSGG3008E | T.SCREW | 2 | FMH BRD./CH.BS | |
| | 78 | QYSBSGG3008E | T.SCREW | 1 | FMC BRD./CH.BS | |
| | 79 | QYSBSGG3008E | T.SCREW | 2 | FMP BRD./FAN BK | |
| △ | 80 | QMF51W2-4R0-J8 | FUSE | 1 | F001 | |
| △ | 81 | QMF51W2-5R0-J8 | FUSE | 1 | F101 | |
| △ | 82 | QMF51W2-5R0-J8 | FUSE | 1 | F102 | |
| △ | 83 | QMF51W2-4R0-J8 | FUSE | 1 | F103 | |
| △ | 84 | QQT0341-003 | POWER TRANSF | 1 | T001 | |
| | 85 | QJJ015-091804 | SIN CR C-C WIRE | 1 | FMH TO DVD MECH | |
| | 86 | QUQH10-0916BJ | CARD WIRE | 1 | FMC TO DVD MECH | |
| | 87 | QUQH10-1708BJ | CARD WIRE | 1 | FMC TO DVD MECH | |
| | 88 | QUQ412-1013DJ | FFC WIRE | 1 | FMC TO DVD MECH | |
| | 89 | QUQ412-1710CJ | FFC WIRE | 1 | FMC TO FMB | |
| | 90 | QUQ412-1410CJ | FFC WIRE | 1 | FMC TO FMB | |
| | 91 | QUQ412-1020CJ | FFC WIRE | 1 | FMC TO SLC | |
| | 92 | QUQ412-0915CJ | FFC WIRE | 1 | FMB TO SLC | |
| | 93 | QUQ412-2410CJ | FFC WIRE | 1 | FMB TO SW | |
| | 94 | QUQ412-0911DJ | FFC WIRE | 1 | FMC TO TUNER | |
| △ | 95 | QMPK200-200-JD | POWER CORD | 1 | | US,UN |
| △ | | QMPR290-200-JN | POWER CORD | 1 | | UX |
| | 96 | VKZ4001-110S | WIRE HOLDER | 2 | | |
| | 97 | GV10062-055A | REAR PANEL | 1 | | US,UN |
| | | GV10062-056A | REAR PANEL | 1 | | UX |
| | 98 | GV10063-002A | REAR COVER | 1 | | |

■ Parts list (General assembly)

Block No. M1MM

| △ | Item | Parts number | Parts name | Q'ty | Description | Area |
|---|------|-----------------|-----------------|------|-----------------|------|
| | 99 | QAR0177-001 | FAN | 1 | SUPPLIER NIDEC | |
| | 100 | QYSBSG3010Z | T.SCREW | 2 | C3 & STAY BRKT | |
| | 101 | QYSBSGY3008E | SPECIAL SCREW | 1 | REAR PNL/CHAS.B | |
| | 102 | QYSBSGY3008E | SPECIAL SCREW | 1 | REAR PNL/AUX | |
| | 103 | QYSBSGY3008E | SPECIAL SCREW | 4 | REAR PNL/H.SINK | |
| | 104 | QYSBSGY3008E | SPECIAL SCREW | 2 | C3/ REAR PANEL | |
| | 105 | QYSBSGY3008E | SPECIAL SCREW | 2 | SPK/ REAR PANEL | |
| | 106 | QYSBSGY3008E | SPECIAL SCREW | 2 | TUNER/REAR PANE | |
| | 107 | QYSBSGY3008E | SPECIAL SCREW | 1 | REAR CVR/R.PNL | |
| | 108 | QYSBSGY3008E | SPECIAL SCREW | 1 | OPTICAL/R.PANEL | |
| | 109 | QYSBSGY3008E | SPECIAL SCREW | 1 | SURR.SPK/R.PANE | |
| | 110 | QYSBSGY3008E | SPECIAL SCREW | 1 | AV COMPULINK/R. | |
| | 111 | QYSBSGY3008E | SPECIAL SCREW | 1 | VIDEO OUT/R.PNL | |
| | 112 | QYSBSGY3008E | SPECIAL SCREW | 1 | REAR PNL/ERT PL | |
| | 113 | GV10055-001A/S/ | METAL COVER | 1 | | |
| | 114 | QYSDSG3006M | T.SCREW | 2 | M.COVER/CHAS.BS | |
| | 115 | QYSBSGY3008E | SPECIAL SCREW | 6 | M.COVER/R.PANEL | |
| | 116 | GV20106-003A | CD FITTING 1 | 1 | DISC 1 | |
| | 117 | GV20107-003A | CD FITTING 2 | 1 | DISC 2 | |
| | 118 | GV20108-003A | CD FITTING 3 | 1 | DISC 3 | |
| | 119 | GV30179-001A | VOLUME KNOB ASS | 1 | | |
| | 120 | GV30180-002A | SUB.WFR.KB.ASSY | 1 | | |
| | 121 | GV30181-002A | SND.MODE KB.ASS | 1 | | |
| | 122 | GV30182-002A | CD FWD.KB.ASSY | 1 | | |
| | 123 | GV20098-019A | WINDOW SCREEN | 1 | | |
| | 124 | GV40181-001A | MIRROR SHEET | 1 | | |
| | 125 | GV30155-001A | VOLUME RING | 1 | | |
| | 126 | GV30151-001A | S/WOOFER RING | 1 | | |
| | 127 | GV30152-001A | SOUND MODE RING | 1 | | |
| | 128 | GV30153-001A | CD FORWARD RING | 1 | | |
| | 129 | GV40186-001A | NUT | 1 | FOR VOLUME ENCO | |
| △ | 130 | QZW0033-001 | STRAIN RELIEF | 1 | | |
| | 131 | GV30141-001A | FL HOLDER | 1 | | |
| | 132 | E3400-439 | FELT SPACER | 2 | | |
| | 134 | GV40083-002A | MIC VOLUME KNOB | 1 | | |

Speaker assembly and parts list

Block No. M 7 M M

SP-XDVB10

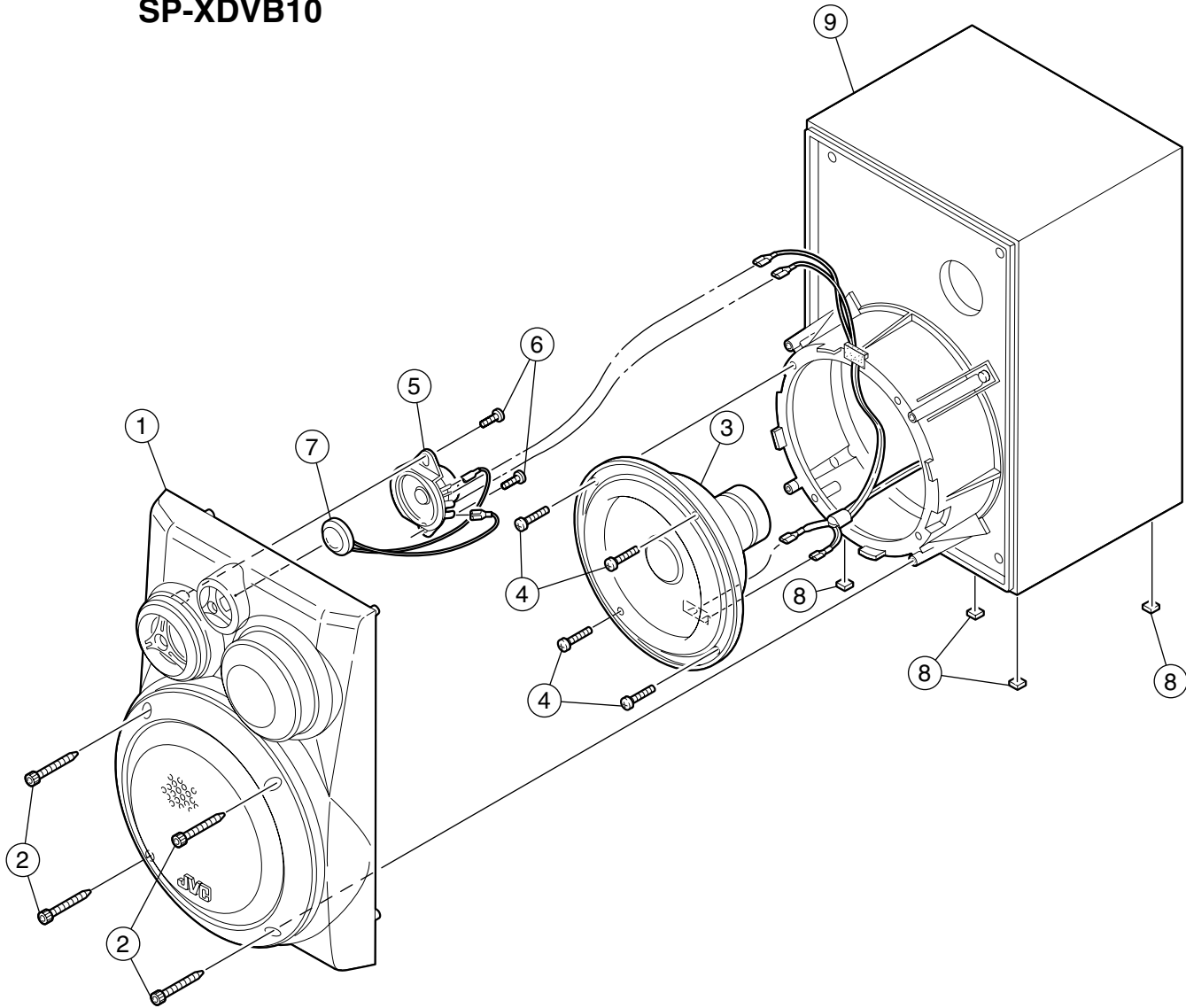

■ Parts list (Speaker assembly) SP-XDVB10

Block No. M7MM

| ⚠ | Item | Parts number | Parts name | Q'ty | Description | Area |
|---|------|-----------------|----------------|------|-------------|------|
| | A | MXDVB10K-SPBOXL | SP BOX ASSY(L) | 1 | | |
| | | MXDVB10K-SPBOXR | SP BOX ASSY(R) | 1 | | |
| | 1 | 199733350151 | FRONT PANEL(R) | 1 | | |
| | | 199733350152 | FRONT PANEL(L) | 1 | | |
| | 2 | 135604161053 | HEXAGON SCREW | 8 | | |
| | 3 | 991061650050 | 16CM WOOFER | 2 | | |
| | 4 | 135604161047 | SCREW M4X16 | 8 | | |
| | 5 | 993060500031 | 5CM TWEETER | 2 | | |
| | 6 | 135604081045 | SCREW M4X8 | 4 | | |
| | 7 | 134720201090 | PIEZO ASSY | 2 | | |
| | 8 | 147780071049 | LEG CUSHION | 8 | | |
| | 9 | ----- | CABINET ASSY | 2 | | |

Speaker assembly and parts list

Block No. M 8 M M

SP-WDVB10

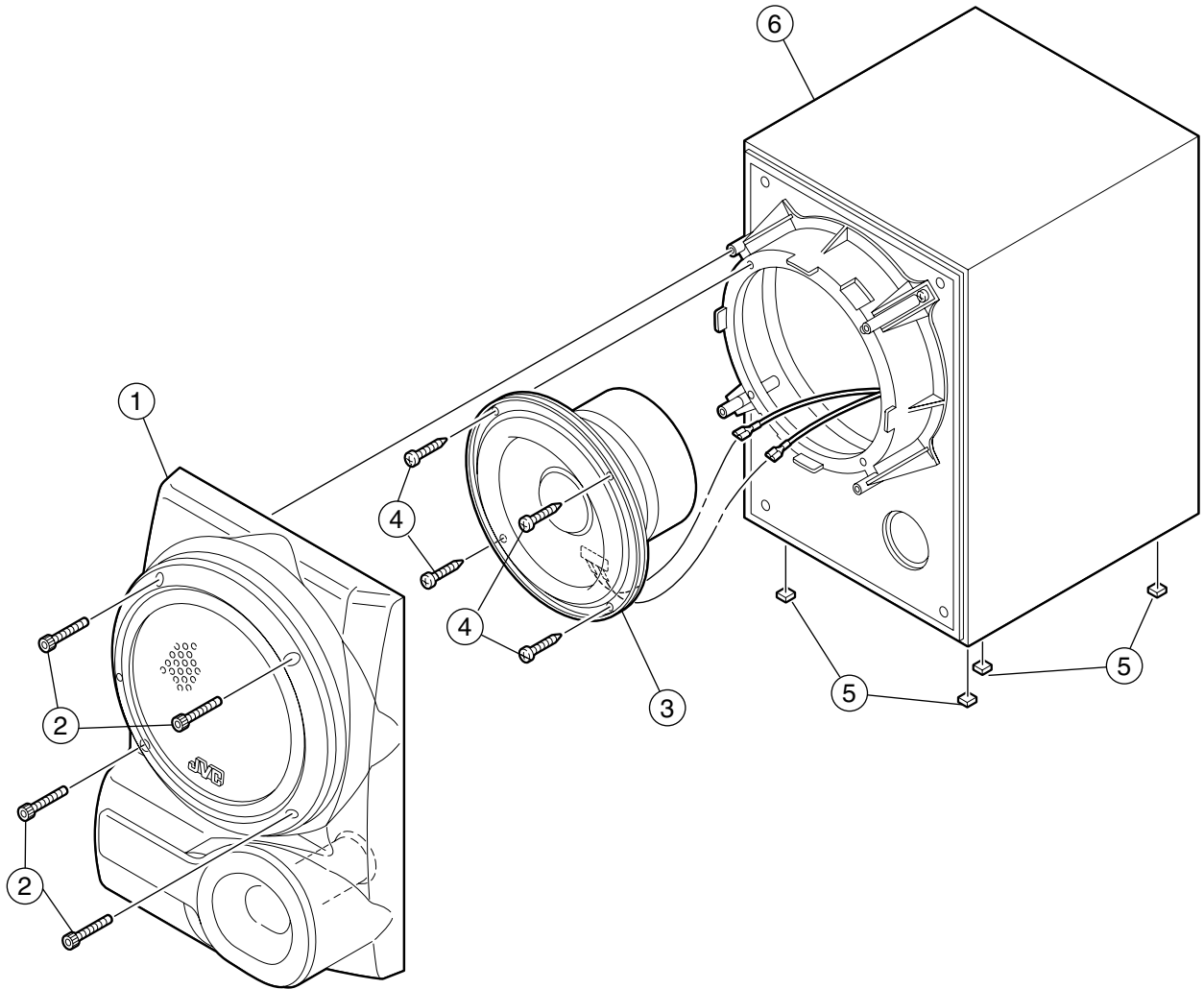

■ Parts list (Speaker assembly) SP-WDVB10

Block No. M8MM

| ⚠ | Item | Parts number | Parts name | Q'ty | Description | Area |
|---|------|-----------------|-----------------|------|-------------|------|
| | A | MXDVB10K-SPKSBL | SP BOX ASSY(L) | 1 | | |
| | | MXDVB10K-SPKSBR | SP BOX ASSY(R) | 1 | | |
| | 1 | 199733350153 | FRONT PANEL(R) | 1 | | |
| | | 199733350154 | FRONT PANEL(L) | 1 | | |
| | 2 | 135604161053 | HEXAGON SCREW | 8 | | |
| | 3 | 991061650051 | 16CM SUB WOOFER | 2 | | |
| | 4 | 135604161047 | SCREW M4X16 | 8 | | |
| | 5 | 147780071049 | LEG CUSHION | 8 | | |
| | 6 | ----- | CABINET ASSY | 2 | | |

DVD mechanism assembly and parts list

Block No. M J M M

FXL-V62-1M

Grease & Three bond

- ★ =EBS0006-013B
- ▲ =CFD-4007ZY2
- =946P
- ◎ =1401B

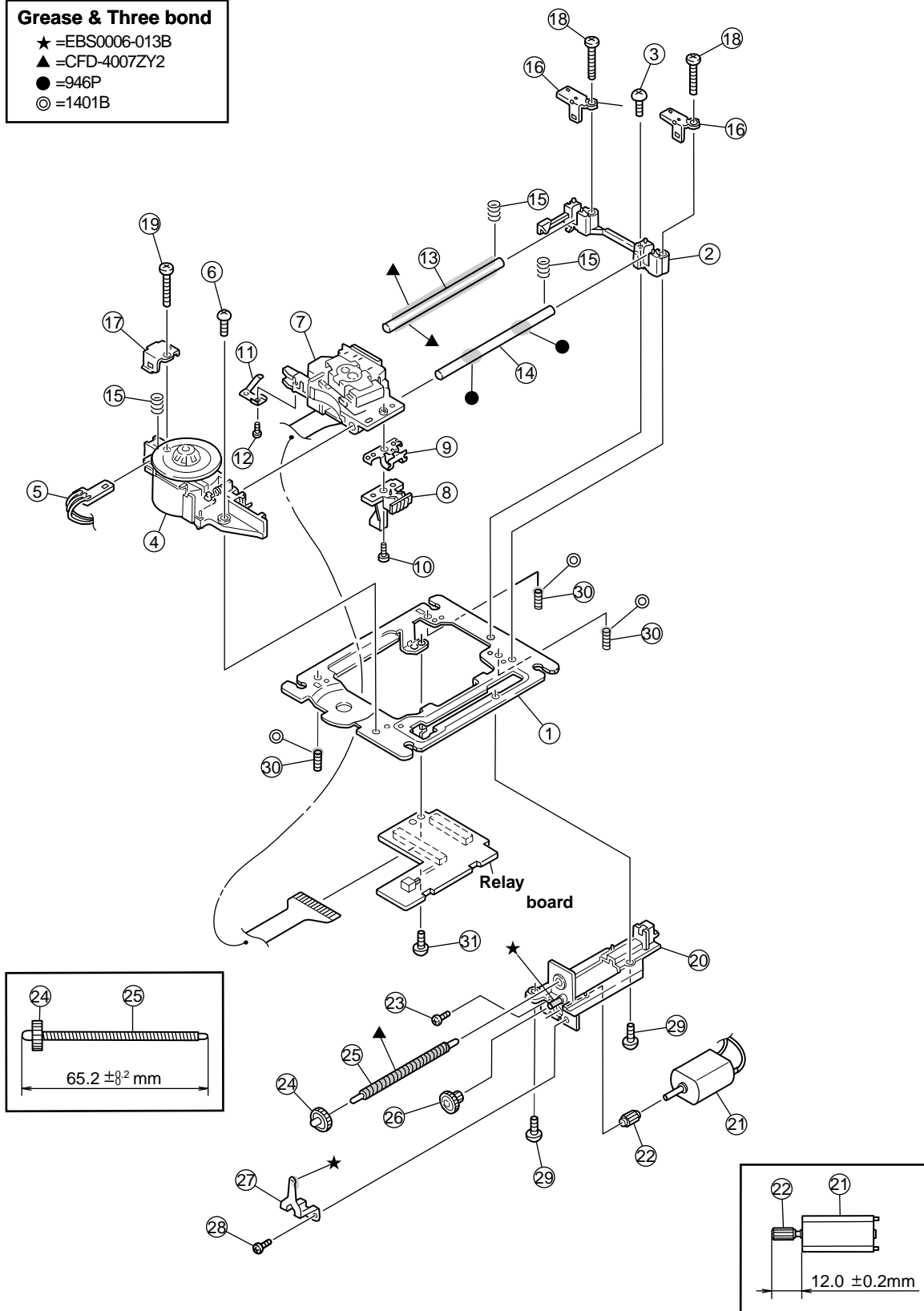

■ Parts list (DVD mechanism)

Block No. MJMM

| △ | Item | Parts number | Parts name | Q'ty | Description | Area |
|---|------|---------------|-----------------|------|-----------------|------|
| | 1 | LV20638-201A | MECHA BASE | 1 | | |
| | 2 | LV20635-001A | SHAFT HOLDER | 1 | | |
| | 3 | QYSBST2606M | T.SCREW | 1 | | |
| | 4 | FXL-V6SPSV-2C | SP.MOTOR ASSY | 1 | | |
| | 5 | QUM193-08B2B2 | PARA RIBON WIRE | 1 | | |
| | 6 | QYSBST2606M | T.SCREW | 1 | FOR S.BASE&M.BA | |
| | 7 | OPTIMA-2010B1 | DVD PICK UP | 1 | | |
| | 8 | LV31670-001A | SWITCH ACTUATOR | 1 | | |
| | 9 | LV31666-002A | LEAD SPRING | 1 | | |
| | 10 | QYSPSGT2040M | SCREW | 1 | | |
| | 11 | LV31743-002A | P.U. SPRING | 1 | | |
| | 12 | QYSPSGT1416M | MINI SCREW | 1 | FOR PU.SPRING | |
| | 13 | LV41121-002A | SHAFT | 1 | MAIN SHAFT | |
| | 14 | LV41121-002A | SHAFT | 1 | SUB SHAFT | |
| | 15 | LV41732-001A | SKEW SPRING | 3 | | |
| | 16 | LV31669-001A | SHAFT STOPPER R | 2 | | |
| | 17 | LV31668-001A | SHAFT STOPPER F | 1 | | |
| | 18 | QYSPST2614M | SCREW | 2 | FOR SSTOPER R | |
| | 19 | QYSPST2614M | SCREW | 1 | FOR SSTOPER F | |
| | 20 | LV31746-004A | FEED HOLDER ASY | 1 | | |
| | 21 | QAR0127-001 | FEED MOTOR | 1 | | |
| | 22 | LV41510-201A | FEED GEAR T | 1 | | |
| | 23 | QYSPSPU2040M | SCREW | 1 | FOR F.M | |
| | 24 | LV41512-201A | FEED GEAR E | 1 | | |
| | 25 | LV41517-001A | LEAD SCREW | 1 | | |
| | 26 | LV41511-202A | FEED GEAR M | 1 | | |
| | 27 | LV31667-001A | THRUST SPRING | 1 | | |
| | 28 | QYSPSPU2040M | SCREW | 1 | FOR F.M | |
| | 29 | QYSBST2606M | T.SCREW | 2 | FOR F.HOLDER | |
| | 30 | QYYASPF2608N | HEX SCREW | 3 | FOR TILT ADJUST | |
| | 31 | QYSBST2606M | T.SCREW | 1 | FOR PW BOARD | |

DVD changer mechanism assembly and parts list

Block No. M K M M

FLM-C5-3M

Grease ★ = EM-30L
 ● = EBS0006-009B
 ▲ = FL-7750

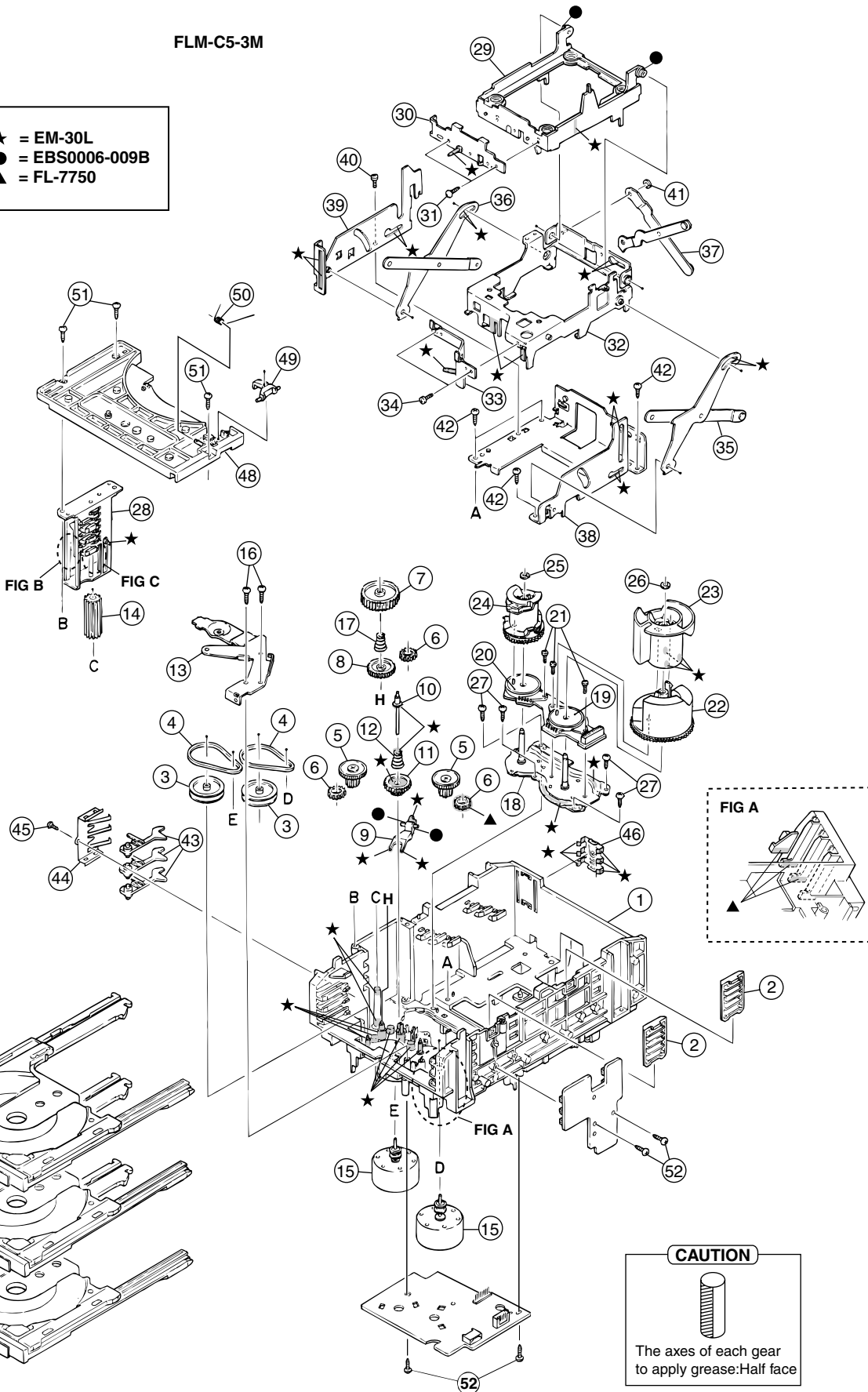
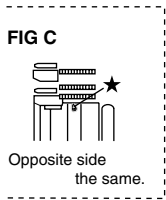
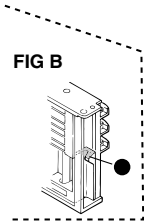

CAUTION

The axes of each gear to apply grease: Half face

■ Parts list (DVD changer mechanism)

Block No. MKMM

| △ | Item | Parts number | Parts name | Q'ty | Description | Area |
|---|------|---------------|------------------|------|-----------------|------|
| | 1 | VKS1144-004 | CHASSIS | 1 | | |
| | 2 | VKS3698-003 | TRAY GUIDE | 2 | | |
| | 3 | VKS5532-003 | PULLEY GEAR | 2 | | |
| | 4 | VKB3000-164 | BELT | 2 | | |
| | 5 | VKS5505-003 | GEAR B | 2 | | |
| | 6 | VKS5506-002 | GEAR C | 3 | | |
| | 7 | VKS5507-002 | CROSS GEAR U | 1 | | |
| | 8 | VKS5508-002 | CROSS GEAR L | 1 | | |
| | 9 | VKS5510-003 | SELECT LEVER | 1 | | |
| | 10 | VKH5769-001 | S.G.SHAFT | 1 | | |
| | 11 | VKS5511-002 | SELECT GEAR | 1 | | |
| | 12 | VKW5155-003 | COMP.SPRING | 1 | FOR SELECT GEAR | |
| | 13 | VKM3846-003 | GEAR BRACKET | 1 | | |
| | 14 | VKS5509-002MM | CYLINDER GEAR | 1 | | |
| | 15 | MSN5D257A-SA2 | D.C.MOTOR ASS'Y | 2 | | |
| | 16 | QYSPSPD2616Z | SCREW | 2 | FOR MOTOR | |
| | 17 | LV40612-001A | COMP.SPRING | 1 | | |
| | 18 | VKM3825-00B | C.G.BASE ASS'Y | 1 | | |
| | 19 | VKZ3172-00ASS | CAM SW. R ASS'Y | 1 | | |
| | 20 | VKZ3173-00ASS | CAM SW. L ASS'Y | 1 | | |
| | 21 | QYSPST2606Z | SCREW | 3 | FOR CAM SW. | |
| | 22 | VKS2263-002MM | CAM R1 | 1 | | |
| | 23 | VKS2264-002MM | CAM R2 | 1 | | |
| | 24 | VKS2265-002MM | CAM GEAR L | 1 | | |
| | 25 | WDL316050MM | SLIT WASHER | 1 | FOR CAM GEAR L | |
| | 26 | WDL316050MM | SLIT WASHER | 1 | | |
| | 27 | QYSBSF2608Z | T.SCREW | 4 | FOR C.GEAR BASE | |
| | 28 | VKS3702-00FMM | DRIVE UNIT | 1 | | |
| | 29 | LV20466-002A | MECHA HOLDER A | 1 | | |
| | 30 | LV41747-002A | BRACKET ASSY | 1 | | |
| | 31 | QYSBSF2606Z | SCREW | 2 | FOR BRACKET | |
| | 32 | VKM3860-00D | MCHA HOLDER ASS | 1 | | |
| | 33 | VKL7802-00D | M.HOLDER C ASS'Y | 1 | | |
| | 34 | QYSDST2604Z | SCREW | 2 | FOR M.HOLDER C | |
| | 35 | VKL7810-00B | LIFTER ASS'Y R | 1 | | |
| | 36 | VKL7811-00B | LIFTER ASS'Y L | 1 | | |
| | 37 | VKL7812-00B | LIFTER ASS'Y H | 1 | | |
| | 38 | VKL2732-003 | LIFTER BASE | 1 | | |
| | 39 | VKM3857-002 | LIFTER BRACKET | 1 | | |
| | 40 | QYSDST2604Z | SCREW | 1 | | |
| | 41 | WDL266035-2 | SLIT WASHER | 1 | | |
| | 42 | QYSBSF2608Z | T.SCREW | 4 | | |
| | 43 | VKS5514-002MM | LOCK LEVER | 3 | | |
| | 44 | VKY3133-002MM | RETURN SPRING | 1 | | |
| | 45 | QYSBSF2608Z | T.SCREW | 1 | FOR RETURN SP. | |
| | 46 | VKY3134-003MM | CLICK SPRING | 1 | | |
| | 47 | VKS2252-00M | TRAY ASS'Y | 3 | | |
| | 48 | VKS2250-004 | TOP BRACKET | 1 | | |
| | 49 | VKS5515-002 | S.TRAY STOPPER | 1 | | |
| | 50 | VKW5156-004 | TORSION SPRING | 1 | | |
| | 51 | QYSBSF2608Z | T.SCREW | 3 | | |
| | 52 | QYSBSF2608Z | T.SCREW | 4 | | |

Cassette mechanism assembly and parts list

Block No. M P M M

SLC-W101M

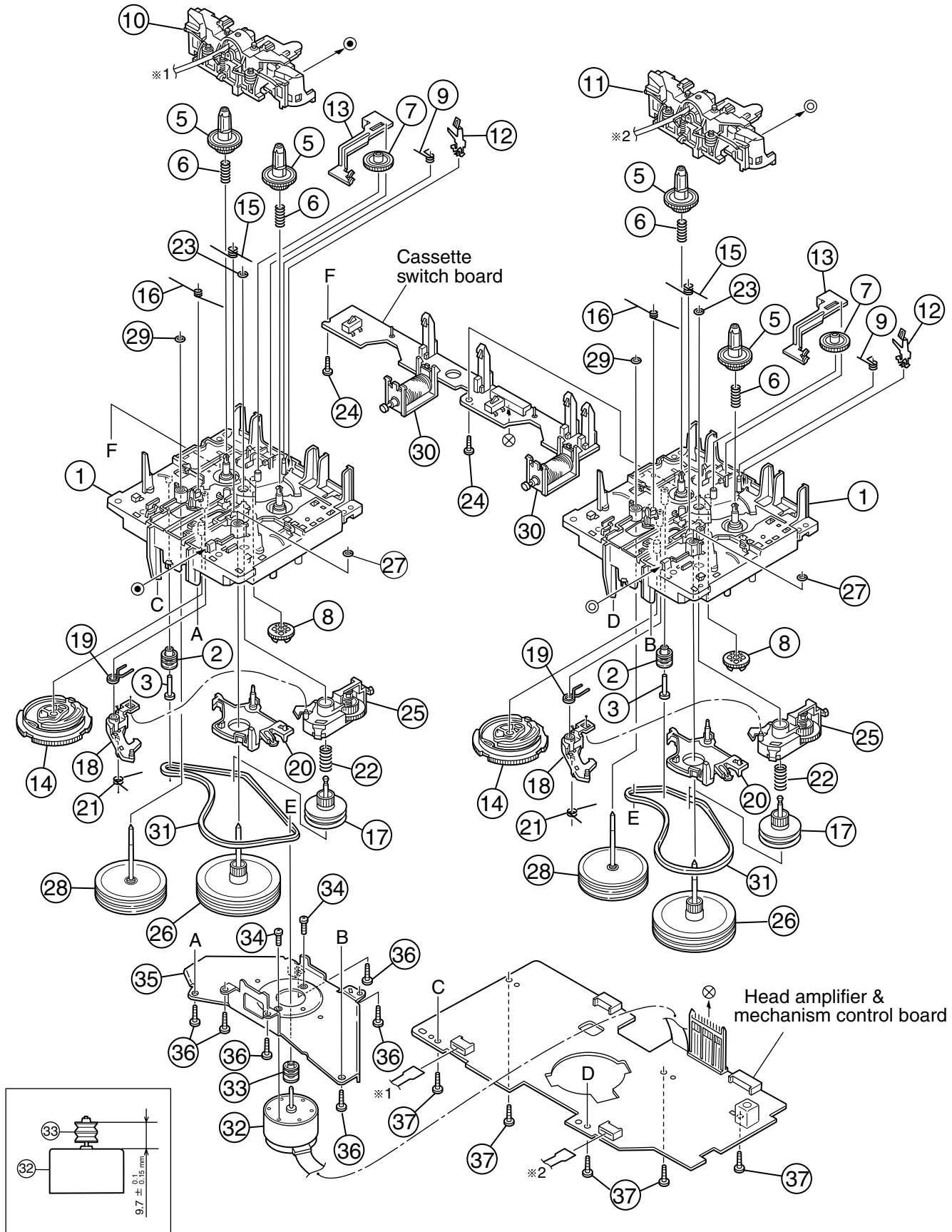

■ Parts list (Cassette mechanism)

Block No. MPMM

| △ | Item | Parts number | Parts name | Q'ty | Description | Area |
|---|------|---------------|-----------------|------|-------------|------|
| | 1 | VKS1165-00K | CHASSIS B.ASS'Y | 2 | | |
| | 2 | VKR4749-004 | IDLE PULLEY | 2 | | |
| | 3 | LV42026-001A | SHAFT | 2 | | |
| | 5 | VKS2274-002 | REEL GEAR | 4 | | |
| | 6 | VKW5286-002 | B.T. SPRING | 4 | | |
| | 7 | VKS5559-001 | PLAY IDLE GEAR | 2 | | |
| | 8 | VKS5597-00B | BLIND | 2 | | |
| | 9 | LV42013-001A | EARTH SPRING | 2 | | |
| | 10 | SLC-P1SVM | HEAD MOUNT ASSY | 1 | | |
| | 11 | SLC-RP1SVM | HEAD MOUNT ASSY | 1 | | |
| | 12 | VKY3149-002 | CASSETTE SP. | 2 | | |
| | 13 | VKM3906-004 | PLAY SW.LEVER | 2 | | |
| | 14 | VKS1166-004 | CONTROL CAM | 2 | | |
| | 15 | VKW5279-002 | HEAD BASE SP(R) | 2 | | |
| | 16 | VKW5280-001 | HEAD BASE SP(L) | 2 | | |
| | 17 | VKS5603-00G | MAIN PULLEY ASY | 2 | | |
| | 18 | VKS3785-001MM | FR ARM | 2 | | |
| | 19 | VKW5284-002 | SWING SPRING | 2 | | |
| | 20 | VKS2278-003 | TRIGGER ARM | 2 | | |
| | 21 | VKW5301-001 | FR SPRING | 2 | | |
| | 22 | VKW5266-001 | ELEVATOR SPRING | 2 | | |
| | 23 | WDL214025 | WASHER | 2 | | |
| | 24 | QYSBSF2005Z | T.SCREW | 2 | | |
| | 25 | VKS3786-00G | CLUTCH ASS'Y | 2 | | |
| | 26 | VKF3205-00B | F.WHEEL ASSY(R) | 2 | | |
| | 27 | WDL183425 | SLIT WASHER | 2 | | |
| | 28 | VKF3207-00B | F.WHEEL ASSY(L) | 2 | | |
| | 29 | WDL173525-6 | SLIT WASHER | 2 | | |
| | 30 | VKZ3174-00A | DC SOLENOID | 2 | | |
| | 31 | LV42764-001A | CAPSTAN BELT(B) | 2 | | |
| | 32 | MSI-5U2LWA | D.C.MOTOR ASS'Y | 1 | | |
| | 33 | VKR4761-001 | MOTOR PULLEY | 1 | | |
| | 34 | QYSPSP2604Z | SCREW | 2 | | |
| | 35 | VKM3907-001 | JOINT BRACKET | 1 | | |
| | 36 | QYSBSF2608Z | T.SCREW | 6 | | |
| | 37 | QYSBSF2608Z | T.SCREW | 5 | FOR P.W.B. | |

Grease point

Grease ★ =JC-525
 ▲ =UD-24
 △ =LEN-320M
 ◎ =MOBIL-1

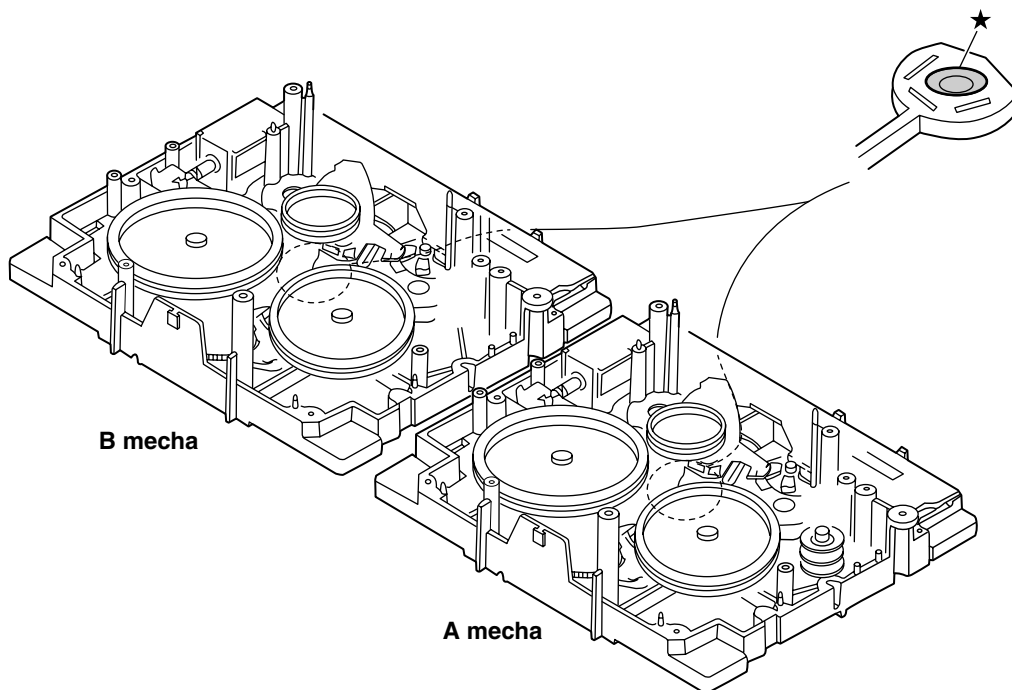
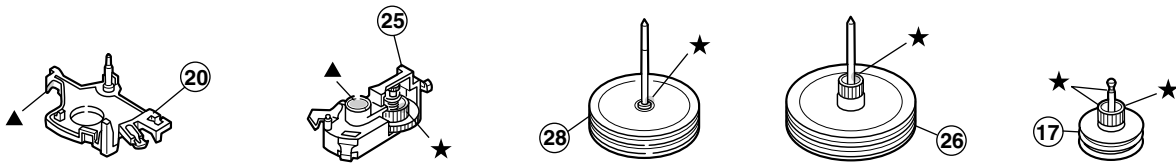
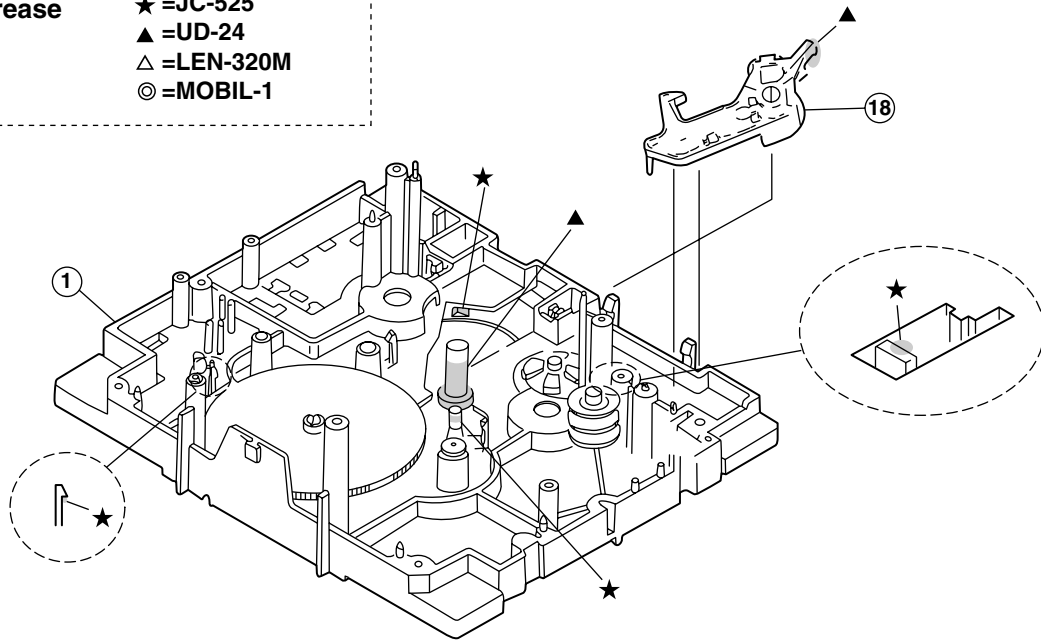

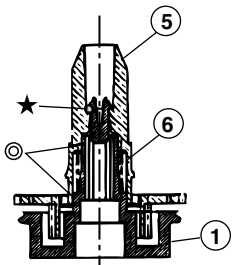
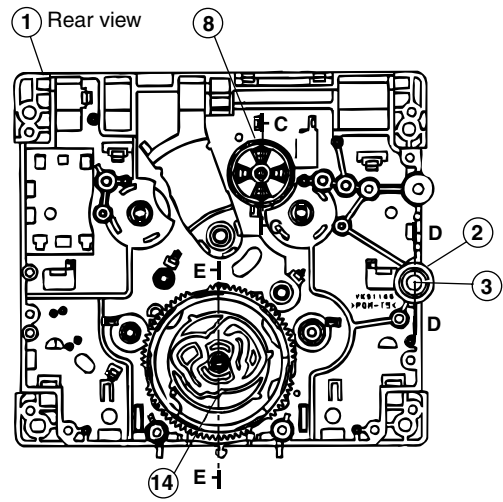
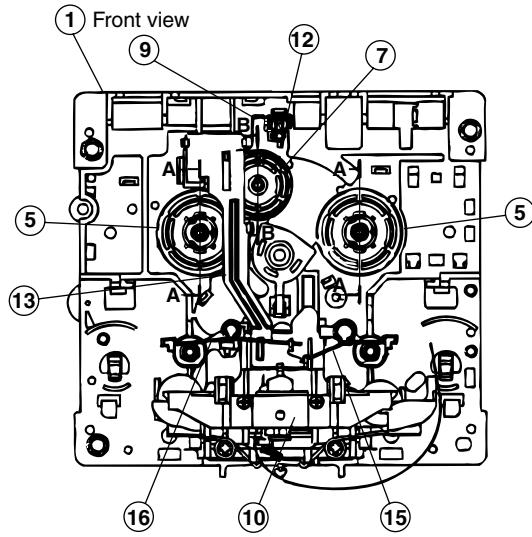

A - A (2/1, 2 places)



B - B (2/1)



C - C (2/1)

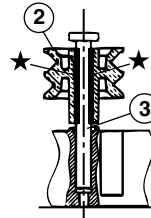

D - D (2/1)

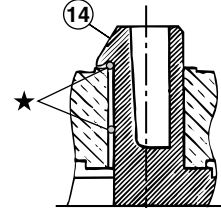

E - E (5/1)

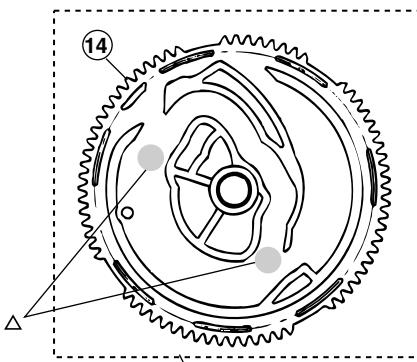
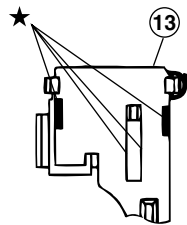
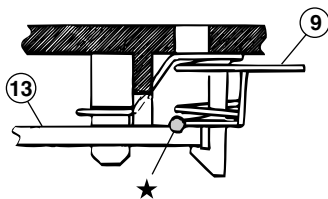

(Dipping)

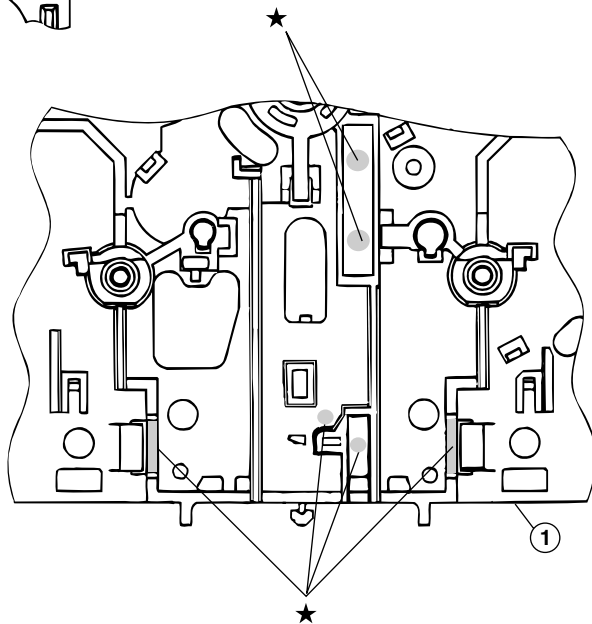

■ Electrical parts list (Power board)

Block No. 01

| △ | Item | Parts number | Parts name | Remarks | Area | △ | Item | Parts number | Parts name | Remarks | Area |
|---|-------|----------------|----------------|---------------|------|---|-------|----------------|--------------|---------------|------|
| | C 201 | QFZ0212-104Z | MM CAPACITOR | .10MF | | | C 344 | QETN1HM-106Z | E CAPACITOR | 10MF 20% 50V | |
| | C 202 | QFZ0212-104Z | MM CAPACITOR | .10MF | | | C 345 | EETC1HM-476ZJC | E CAPACITOR | | |
| | C 203 | QFZ0212-104Z | MM CAPACITOR | .10MF | | | C 346 | QCBB1HK-221Y | C CAPACITOR | 220PF 10% 50V | |
| | C 204 | EETB1HM-478JC | E CAPACITOR | | | | C 347 | QCBB1HK-221Y | C CAPACITOR | 220PF 10% 50V | |
| | C 205 | EETB1HM-478JC | E CAPACITOR | | | | C 348 | QCBB1HK-221Y | C CAPACITOR | 220PF 10% 50V | |
| | C 211 | QFZ0212-104Z | MM CAPACITOR | .10MF | | | C 349 | EETC1HM-105ZJC | E CAPACITOR | | |
| | C 212 | QFZ0212-104Z | MM CAPACITOR | .10MF | | | C 703 | QCBB1HK-471Y | C CAPACITOR | 470PF 10% 50V | |
| | C 213 | QFZ0212-104Z | MM CAPACITOR | .10MF | | | C 704 | QCBB1HK-471Y | C CAPACITOR | 470PF 10% 50V | |
| | C 214 | EETB1HM-228JC | AL E.CAPACITOR | | | | C 705 | QCBB1HK-221Y | C CAPACITOR | 220PF 10% 50V | |
| | C 215 | EETB1HM-228JC | AL E.CAPACITOR | | | | C 706 | QCBB1HK-221Y | C CAPACITOR | 220PF 10% 50V | |
| | C 216 | QETN1JM-107Z | E CAPACITOR | 100MF 20% 35V | | | C 707 | QETN1JM-476Z | E CAPACITOR | 47MF 20% 63V | |
| | C 217 | EETC2AM-476ZJC | E CAPACITOR | | | | C 708 | QETN1JM-476Z | E CAPACITOR | 47MF 20% 63V | |
| | C 218 | EETC1HM-226ZJC | E CAPACITOR | | | | C 709 | QCSB1HK-4R7Y | C CAPACITOR | 4.7PF 10% 50V | |
| | C 219 | QDYB1CM-103Y | C CAPACITOR | | | | C 710 | QCSB1HK-4R7Y | C CAPACITOR | 4.7PF 10% 50V | |
| | C 220 | EETC1HM-226ZJC | E CAPACITOR | | | | C 711 | QFV72AJ-104Z | MF CAPACITOR | .10MF 5% 100V | |
| | C 221 | EETC1HM-475ZJC | E CAPACITOR | | | | C 712 | QFV72AJ-104Z | MF CAPACITOR | .10MF 5% 100V | |
| | C 222 | EETC1HM-475ZJC | E CAPACITOR | | | | C 713 | QFLC1HJ-473Z | M CAPACITOR | .047MF 5% 50V | |
| | C 224 | QETN1JM-476Z | E CAPACITOR | 47MF 20% 63V | | | C 714 | QFLC1HJ-473Z | M CAPACITOR | .047MF 5% 50V | |
| | C 232 | EETB1EM-688JC | AL E.CAPACITOR | | | | C 715 | QFLC1HJ-473Z | M CAPACITOR | .047MF 5% 50V | |
| | C 260 | QEK1HM-226Z | E CAPACITOR | 22MF 20% 50V | | | C 716 | QFLC1HJ-473Z | M CAPACITOR | .047MF 5% 50V | |
| | C 261 | EETC1HM-226ZJC | E CAPACITOR | | | | C 721 | QETC1EM-106Z | E CAPACITOR | 10MF 20% 25V | |
| | C 262 | QDYB1CM-103Y | C CAPACITOR | | | | C 722 | QETC1EM-106Z | E CAPACITOR | 10MF 20% 25V | |
| | C 270 | QEK1AM-107Z | E CAPACITOR | 100MF 20% 10V | | | C 723 | EETC1AM-107ZJC | E CAPACITOR | | |
| | C 271 | EETC1CM-227ZJC | E CAPACITOR | | | | C 726 | QETC1EM-106Z | E CAPACITOR | 10MF 20% 25V | |
| | C 280 | QDXB1CM-222Y | C CAPACITOR | | | | C 729 | EETC1CM-476ZJC | E CAPACITOR | | |
| | C 281 | FQCF31HP-473Z | C CAPACITOR | | | | C 730 | FQCF31HZ-223Z | D CAPACITOR | | |
| | C 282 | QDXB1CM-222Y | C CAPACITOR | | | | C 731 | FQCF31HZ-223Z | D CAPACITOR | | |
| | C 283 | FQCF31HP-473Z | C CAPACITOR | | | | C 739 | EETC1HM-105ZJC | E CAPACITOR | | |
| | C 285 | QDXB1CM-222Y | C CAPACITOR | | | | C 751 | FQCF31HZ-223Z | D CAPACITOR | | |
| | C 286 | FQCF31HP-473Z | C CAPACITOR | | | | C 752 | FQCF31HZ-223Z | D CAPACITOR | | |
| | C 287 | QDXB1CM-222Y | C CAPACITOR | | | | C 753 | QCBB1HK-221Y | C CAPACITOR | 220PF 10% 50V | |
| | C 288 | FQCF31HP-473Z | C CAPACITOR | | | | C 754 | QCBB1HK-221Y | C CAPACITOR | 220PF 10% 50V | |
| | C 299 | EETC0JM-107ZJC | AL E.CAPACITOR | | | | C 755 | QCBB1HK-221Y | C CAPACITOR | 220PF 10% 50V | |
| | C 301 | EETC1CM-107ZJC | E CAPACITOR | | | | C 756 | QCBB1HK-221Y | C CAPACITOR | 220PF 10% 50V | |
| | C 302 | EETC1AM-227ZJC | E CAPACITOR | | | | C 757 | QETN1JM-476Z | E CAPACITOR | 47MF 20% 63V | |
| | C 303 | QDYB1CM-103Y | C CAPACITOR | | | | C 758 | QETN1JM-476Z | E CAPACITOR | 47MF 20% 63V | |
| | C 304 | EETC1HM-106ZJC | E CAPACITOR | | | | C 759 | QCSB1HJ-100Y | C CAPACITOR | 10PF 5% 50V | |
| | C 306 | EETC0JM-107ZJC | E CAPACITOR | | | | C 760 | QCSB1HJ-100Y | C CAPACITOR | 10PF 5% 50V | |
| | C 307 | EETC1HM-106ZJC | E CAPACITOR | | | | C 761 | EETC1HM-476ZJC | E CAPACITOR | | |
| | C 308 | EETC0JM-107ZJC | E CAPACITOR | | | | C 762 | EETC1HM-476ZJC | E CAPACITOR | | |
| | C 309 | EETC1HM-106ZJC | E CAPACITOR | | | | C 763 | QFLC1HJ-473Z | M CAPACITOR | .047MF 5% 50V | |
| | C 310 | EETC1HM-226ZJC | E CAPACITOR | | | | C 764 | QFLC1HJ-473Z | M CAPACITOR | .047MF 5% 50V | |
| | C 311 | EETC0JM-107ZJC | E CAPACITOR | | | | C 765 | QFLC1HJ-473Z | M CAPACITOR | .047MF 5% 50V | |
| | C 321 | QCBB1HK-221Y | C CAPACITOR | 220PF 10% 50V | | | C 766 | QFLC1HJ-473Z | M CAPACITOR | .047MF 5% 50V | |
| | C 322 | QETC1EM-106Z | E CAPACITOR | 10MF 20% 25V | | | C 771 | QETC1EM-106Z | E CAPACITOR | 10MF 20% 25V | |
| | C 323 | QCBB1HK-221Y | C CAPACITOR | 220PF 10% 50V | | | C 772 | QETC1EM-106Z | E CAPACITOR | 10MF 20% 25V | |
| | C 324 | QETC1EM-106Z | E CAPACITOR | 10MF 20% 25V | | | C 773 | QETN1HM-106Z | E CAPACITOR | 10MF 20% 50V | |
| | C 325 | QCBB1HK-221Y | C CAPACITOR | 220PF 10% 50V | | | C 774 | QETN1HM-106Z | E CAPACITOR | 10MF 20% 50V | |
| | C 326 | QETC1EM-106Z | E CAPACITOR | 10MF 20% 25V | | | C 789 | EETC1HM-105ZJC | E CAPACITOR | | |
| | C 328 | QFLC1HJ-473Z | M CAPACITOR | .047MF 5% 50V | | | C 790 | EETC1EM-476ZJC | E CAPACITOR | | |
| | C 329 | QFLC1HJ-473Z | M CAPACITOR | .047MF 5% 50V | | | CN201 | QGB2510J1-08 | CONNECTOR | | |
| | C 330 | QCSB1HJ-100Y | C CAPACITOR | 10PF 5% 50V | | | CN202 | QGB2510J1-09 | CONNECTOR | | |
| | C 331 | QETN1JM-476Z | E CAPACITOR | 47MF 20% 63V | | | CN203 | QGB2510J1-04 | CONNECTOR | | |
| | C 333 | QFLC1HJ-473Z | M CAPACITOR | .047MF 5% 50V | | | CN204 | QGA3901C1-07 | CONNECTOR | | |
| | C 334 | QFLC1HJ-473Z | M CAPACITOR | .047MF 5% 50V | | | CN205 | QGB2510J1-15 | CONNECTOR | | |
| | C 335 | QCSB1HJ-100Y | C CAPACITOR | 10PF 5% 50V | | | CN206 | QGB2510J1-14 | CONNECTOR | | |
| | C 336 | QETN1JM-476Z | E CAPACITOR | 47MF 20% 63V | | | CN207 | QGB2510J1-08 | CONNECTOR | | |
| | C 338 | QFLC1HJ-473Z | M CAPACITOR | .047MF 5% 50V | | | CN287 | QGB2510K2-08 | CONNECTOR | | |
| | C 339 | QFLC1HJ-473Z | M CAPACITOR | .047MF 5% 50V | | | CN310 | QGB2510K2-14 | CONNECTOR | | |
| | C 340 | QCSB1HJ-100Y | C CAPACITOR | 10PF 5% 50V | | | CN311 | QGB2510K2-15 | CONNECTOR | | |
| | C 341 | QETN1JM-476Z | E CAPACITOR | 47MF 20% 63V | | | CN312 | QGA2001F1-09 | CONNECTOR | | |
| | C 342 | EETC1HM-476ZJC | E CAPACITOR | | | | CN701 | QGB2510K2-15 | CONNECTOR | | |
| | C 343 | QETN1HM-106Z | E CAPACITOR | 10MF 20% 50V | | | CN703 | QGD2504C1-03Z | SOCKET | | |

■ Electrical parts list (Power board)

Block No. 01

| △ | Item | Parts number | Parts name | Remarks | Area | △ | Item | Parts number | Parts name | Remarks | Area |
|---|-------|---------------|-----------------|---------|------|---|-------|----------------|--------------|--------------|------|
| | CN705 | QGA2501F1-02 | CONNECTOR | | | △ | IC752 | STK402-040 | IC | | |
| | CN772 | QGB2510K2-06 | CONNECTOR | | | | J 280 | QNB0107-001 | SPK TERMINAL | | |
| △ | D 201 | 1N5402M-20 | DIODE | | | | L 301 | QQR1277-001Z | F.BEADS | | |
| △ | D 202 | 1N5402M-20 | DIODE | | | | L 321 | QQLZ035-R39 | INDUCTOR | | |
| △ | D 203 | 1N5402M-20 | DIODE | | | | L 322 | QQLZ035-R39 | INDUCTOR | | |
| △ | D 204 | 1N5402M-20 | DIODE | | | | L 323 | QQLZ035-R39 | INDUCTOR | | |
| △ | D 211 | 1N5402M-20 | DIODE | | | | L 701 | QQLZ035-R39 | INDUCTOR | | |
| △ | D 212 | 1N5402M-20 | DIODE | | | | L 702 | QQLZ035-R39 | INDUCTOR | | |
| △ | D 213 | 1N5402M-20 | DIODE | | | | L 751 | QQLZ035-R39 | INDUCTOR | | |
| △ | D 214 | 1N5402M-20 | DIODE | | | | L 752 | QQLZ035-R39 | INDUCTOR | | |
| △ | D 216 | 1N4003S-T5 | SI DIODE | | | | Q 211 | 2SB740/BC/-T | TRANSISTOR | | |
| △ | D 217 | 1N4003S-T5 | SI DIODE | | | | Q 212 | KTC3199/GL/-T | TRANSISTOR | | |
| △ | D 218 | 1N4003S-T5 | SI DIODE | | | | Q 213 | KTC3199/GL/-T | TRANSISTOR | | |
| | D 219 | DZ33BSC-T2 | ZENER DIODE | | | | Q 261 | 2SB1274/RS/ | TRANSISTOR | | |
| | D 220 | DZ9.1BSC-T2 | ZENER DIODE | | | | Q 325 | KTA1267/YG/-T | TRANSISTOR | | |
| | D 224 | 1SS119-041-T2 | SI DIODE | | | | Q 326 | KTA1267/YG/-T | TRANSISTOR | | |
| | D 225 | 1SS119-041-T2 | SI DIODE | | | | Q 327 | KTA1267/YG/-T | TRANSISTOR | | |
| △ | D 231 | 2A02-M | DIODE | | | | Q 331 | KTC3199/GL/-T | TRANSISTOR | | |
| △ | D 232 | 2A02-M | DIODE | | | | Q 332 | 2SD1913/RS/ | TRANSISTOR | | |
| △ | D 233 | 2A02-M | DIODE | | | | Q 333 | KRA104M-T | D.TRANSISTOR | | |
| △ | D 234 | 2A02-M | DIODE | | | | Q 334 | KRC102M-T | D.TRANSISTOR | | |
| | D 260 | DZ11BSC-T2 | ZENER DIODE | | | | Q 335 | KTC3199/GL/-T | TRANSISTOR | | |
| | D 262 | DZ10BSC-T2 | ZENER DIODE | | | | Q 336 | 2SB1274/RS/ | TRANSISTOR | | |
| | D 270 | DZ10BSC-T2 | Z.DIODE | | | | Q 337 | 2SD2061/EF/ | TRANSISTOR | | |
| | D 271 | DZ13BSC-T2 | ZENER DIODE | | | | Q 338 | KTC3199/GL/-T | TRANSISTOR | | |
| | D 301 | DZ10BSA-T2 | ZENER DIODE | | | | Q 339 | KTC3199/GL/-T | TRANSISTOR | | |
| | D 302 | DZ11BSC-T2 | ZENER DIODE | | | | Q 340 | 2SD2061/EF/ | TRANSISTOR | | |
| | D 303 | DZ3.9BSB-T2 | ZENER DIODE | | | | Q 341 | KRA104M-T | D.TRANSISTOR | | |
| | D 305 | DZ8.2BSC-T2 | ZENER DIODE | | | | Q 342 | KRC104M-T | D.TRANSISTOR | | |
| | D 306 | 1SS119-041-T2 | SI DIODE | | | | Q 701 | KTA1268/GL/-T | TRANSISTOR | | |
| | D 307 | DZ6.8BSC-T2 | ZENER DIODE | | | | Q 702 | KTA1268/GL/-T | TRANSISTOR | | |
| | D 308 | DZ4.3BSB-T2 | ZENER DIODE | | | | Q 710 | 2SA965/OY/-T | TRANSISTOR | | |
| | D 309 | DZ6.8BSC-T2 | ZENER DIODE | | | | Q 711 | KTC3200/GL/-T | TRANSISTOR | | |
| | D 311 | 1SS119-041-T2 | SI DIODE | | | | Q 712 | KTA1268/GL/-T | TRANSISTOR | | |
| | D 321 | DZ9.1BSC-T2 | ZENER DIODE | | | | Q 713 | 2SC2235/OY/-T | TRANSISTOR | | |
| | D 322 | 1SS119-041-T2 | SI DIODE | | | | Q 726 | 2SC2389S/SE/-T | TRANSISTOR | | |
| | D 323 | 1SS119-041-T2 | SI DIODE | | | | Q 727 | KTA1268/GL/-T | TRANSISTOR | | |
| | D 324 | 1SS119-041-T2 | SI DIODE | | | | Q 728 | KTC3199/GL/-T | TRANSISTOR | | |
| | D 325 | DZ9.1BSC-T2 | ZENER DIODE | | | | Q 733 | 2SC3576-JVC-T | TRANSISTOR | | |
| | D 703 | DZ15BSC-T2 | ZENER DIODE | | | | Q 734 | 2SC3576-JVC-T | TRANSISTOR | | |
| | D 704 | DZ15BSC-T2 | ZENER DIODE | | | | Q 735 | 2SC3576-JVC-T | TRANSISTOR | | |
| | D 719 | 1SS119-041-T2 | SI DIODE | | | | Q 736 | 2SC3576-JVC-T | TRANSISTOR | | |
| | D 720 | 1SS119-041-T2 | SI DIODE | | | | Q 737 | KRA102M-T | D.TRANSISTOR | | |
| | D 723 | DZ36BSA-T2 | ZENER DIODE | | | | Q 751 | KTA1268/GL/-T | TRANSISTOR | | |
| | D 724 | DZ36BSA-T2 | ZENER DIODE | | | | Q 752 | KTA1268/GL/-T | TRANSISTOR | | |
| | D 726 | 1SS119-041-T2 | SI DIODE | | | | Q 762 | KTA1267/YG/-T | TRANSISTOR | | |
| | D 728 | 1SS119-041-T2 | SI DIODE | | | | Q 763 | KRC102M-T | D.TRANSISTOR | | |
| | D 769 | 1SS119-041-T2 | SI DIODE | | | | Q 792 | KTC3203/OY/-T | TRANSISTOR | | |
| | D 770 | 1SS119-041-T2 | SI DIODE | | | △ | R 202 | QRZ9042-2R2X | F RESISTOR | 2.2 1/4W | |
| | D 772 | DZ9.1BSC-T2 | ZENER DIODE | | | | R 203 | QRE141J-752Y | C RESISTOR | 7.5K 5% 1/4W | |
| | D 787 | 1SS119-041-T2 | SI DIODE | | | | R 204 | QRE141J-223Y | C RESISTOR | 22K 5% 1/4W | |
| | D 788 | 1SS119-041-T2 | SI DIODE | | | | R 205 | QRE141J-104Y | C RESISTOR | 100K 5% 1/4W | |
| | D 790 | 1SS119-041-T2 | SI DIODE | | | | R 211 | QRE141J-103Y | C RESISTOR | 10K 5% 1/4W | |
| | D 791 | 1SS119-041-T2 | SI DIODE | | | | R 212 | QRE141J-103Y | C RESISTOR | 10K 5% 1/4W | |
| | D 792 | DZ5.1BSB-T2 | ZENER DIODE | | | | R 213 | QRE141J-103Y | C RESISTOR | 10K 5% 1/4W | |
| | EP201 | QNZ0136-001Z | EARTH PLATE | | | | R 214 | QRE141J-103Y | C RESISTOR | 10K 5% 1/4W | |
| | FW313 | QUM154-18DGZ4 | PARA RIBON WIRE | | | | R 215 | QRE141J-473Y | C RESISTOR | 47K 5% 1/4W | |
| | HS270 | LE40505-001A | HEAT SINK | | | | R 216 | QRE141J-473Y | C RESISTOR | 47K 5% 1/4W | |
| | IC270 | KIA7809API | IC | | | | R 217 | QRE141J-273Y | C RESISTOR | 27K 5% 1/4W | |
| | IC271 | KIA7812API | +12V REG.IC | | | | R 218 | QRE141J-273Y | C RESISTOR | 27K 5% 1/4W | |
| | IC321 | STK402-230 | IC | | | | R 220 | QRK126J-121X | C RESISTOR | 120 5% 1/2W | |
| | IC330 | KIA7805API | IC | | | | R 221 | QRE141J-682Y | C RESISTOR | 6.8K 5% 1/4W | |
| △ | IC701 | STK412-090 | IC | | | | R 250 | QRE141J-103Y | C RESISTOR | 10K 5% 1/4W | |

■ Electrical parts list (Power board)

Block No. 01

| △ | Item | Parts number | Parts name | Remarks | Area | △ | Item | Parts number | Parts name | Remarks | Area | |
|---|-------|--------------|----------------|--------------|------|---|-------|--------------|----------------|----------------|------------|--|
| | R 260 | QRE141J-272Y | C RESISTOR | 2.7K 5% 1/4W | | | R 706 | QRJ146J-821X | UNF C RESISTOR | 820 5% 1/4W | | |
| | R 261 | QRE141J-562Y | C RESISTOR | 5.6K 5% 1/4W | | | R 707 | QRE141J-563Y | C RESISTOR | 56K 5% 1/4W | | |
| | R 262 | QRJ146J-100X | UNF C RESISTOR | 10 5% 1/4W | | | R 708 | QRE141J-563Y | C RESISTOR | 56K 5% 1/4W | | |
| | R 280 | QRJ146J-4R7X | UNF C RESISTOR | 4.7 5% 1/4W | | | R 709 | QRJ146J-100X | UNF C RESISTOR | 10 5% 1/4W | | |
| | R 281 | QRJ146J-4R7X | UNF C RESISTOR | 4.7 5% 1/4W | | | R 710 | QRJ146J-100X | UNF C RESISTOR | 10 5% 1/4W | | |
| | R 285 | QRJ146J-4R7X | UNF C RESISTOR | 4.7 5% 1/4W | | | R 711 | QRJ146J-100X | UNF C RESISTOR | 10 5% 1/4W | | |
| | R 286 | QRJ146J-4R7X | UNF C RESISTOR | 4.7 5% 1/4W | | | R 712 | QRJ146J-100X | UNF C RESISTOR | 10 5% 1/4W | | |
| | R 301 | QRE141J-561Y | C RESISTOR | 560 5% 1/4W | | | R 713 | QRE141J-102Y | C RESISTOR | 1.0K 5% 1/4W | | |
| | R 302 | QRE141J-562Y | C RESISTOR | 5.6K 5% 1/4W | | | R 714 | QRE141J-102Y | C RESISTOR | 1.0K 5% 1/4W | | |
| | R 303 | QRE141J-103Y | C RESISTOR | 10K 5% 1/4W | | | R 715 | QRE141J-562Y | C RESISTOR | 5.6K 5% 1/4W | | |
| | R 304 | QRE141J-512Y | C RESISTOR | 5.1K 5% 1/4W | | | R 716 | QRE141J-562Y | C RESISTOR | 5.6K 5% 1/4W | | |
| | R 305 | QRE141J-152Y | C RESISTOR | 1.5K 5% 1/4W | | | R 717 | QRE141J-103Y | C RESISTOR | 10K 5% 1/4W | | |
| | R 306 | QRE141J-331Y | C RESISTOR | 330 5% 1/4W | | | R 718 | QRE141J-103Y | C RESISTOR | 10K 5% 1/4W | | |
| | R 307 | QRE141J-331Y | C RESISTOR | 330 5% 1/4W | | | R 719 | QRE141J-682Y | C RESISTOR | 6.8K 5% 1/4W | | |
| | R 308 | QRE141J-331Y | C RESISTOR | 330 5% 1/4W | | | R 720 | QRE141J-682Y | C RESISTOR | 6.8K 5% 1/4W | | |
| | R 309 | QRE141J-681Y | C RESISTOR | 680 5% 1/4W | | | R 721 | QRE141J-104Y | C RESISTOR | 100K 5% 1/4W | | |
| | R 310 | QRE141J-122Y | C RESISTOR | 1.2K 5% 1/4W | | | R 722 | QRE141J-104Y | C RESISTOR | 100K 5% 1/4W | | |
| | R 311 | QRE141J-201Y | C RESISTOR | 200 5% 1/4W | | | R 723 | QRE141J-104Y | C RESISTOR | 100K 5% 1/4W | | |
| | R 312 | QRE141J-201Y | C RESISTOR | 200 5% 1/4W | | | R 724 | QRE141J-103Y | C RESISTOR | 10K 5% 1/4W | | |
| | R 316 | QRE141J-103Y | C RESISTOR | 10K 5% 1/4W | | | R 725 | QRE141J-104Y | C RESISTOR | 100K 5% 1/4W | | |
| | R 321 | QRE141J-102Y | C RESISTOR | 1.0K 5% 1/4W | | | R 726 | QRE141J-103Y | C RESISTOR | 10K 5% 1/4W | | |
| | R 322 | QRE141J-563Y | C RESISTOR | 56K 5% 1/4W | | | R 727 | QRE141J-472Y | C RESISTOR | 4.7K 5% 1/4W | | |
| | R 323 | QRE141J-102Y | C RESISTOR | 1.0K 5% 1/4W | | | R 728 | QRE141J-472Y | C RESISTOR | 4.7K 5% 1/4W | | |
| | R 324 | QRE141J-563Y | C RESISTOR | 56K 5% 1/4W | | | R 729 | QRE141J-472Y | C RESISTOR | 4.7K 5% 1/4W | | |
| | R 325 | QRE141J-102Y | C RESISTOR | 1.0K 5% 1/4W | | | R 730 | QRE141J-472Y | C RESISTOR | 4.7K 5% 1/4W | | |
| | R 326 | QRE141J-563Y | C RESISTOR | 56K 5% 1/4W | | | R 731 | QRL01DJ-821X | OMF RESISTOR | 820 5% 1/1W | | |
| | R 327 | QRJ146J-100X | UNF C RESISTOR | 10 5% 1/4W | | | R 732 | QRL01DJ-821X | OMF RESISTOR | 820 5% 1/1W | | |
| | R 328 | QRJ146J-100X | UNF C RESISTOR | 10 5% 1/4W | | | R 733 | QRE141J-682Y | C RESISTOR | 6.8K 5% 1/4W | | |
| | R 329 | QRE141J-753Y | C RESISTOR | 75K 5% 1/4W | | | R 734 | QRE141J-682Y | C RESISTOR | 6.8K 5% 1/4W | | |
| | R 330 | QRJ146J-122X | UNF C RESISTOR | 1.2K 5% 1/4W | | | R 735 | QRZ0218-R22 | C RESISTOR | 1/2W | | |
| | R 331 | QRJ146J-100X | UNF C RESISTOR | 10 5% 1/4W | | | R 736 | QRZ0218-R22 | C RESISTOR | 1/2W | | |
| | R 332 | QRJ146J-100X | UNF C RESISTOR | 10 5% 1/4W | | | R 737 | QRE141J-102Y | C RESISTOR | 1.0K 5% 1/4W | | |
| | R 333 | QRE141J-753Y | C RESISTOR | 75K 5% 1/4W | | | R 738 | QRE141J-102Y | C RESISTOR | 1.0K 5% 1/4W | | |
| | R 334 | QRJ146J-122X | UNF C RESISTOR | 1.2K 5% 1/4W | | | R 739 | QRE141J-333Y | C RESISTOR | 33K 5% 1/4W | | |
| | R 335 | QRJ146J-100X | UNF C RESISTOR | 10 5% 1/4W | | | R 740 | QRE141J-104Y | C RESISTOR | 100K 5% 1/4W | | |
| | R 336 | QRJ146J-100X | UNF C RESISTOR | 10 5% 1/4W | | | R 741 | QRE141J-222Y | C RESISTOR | 2.2K 5% 1/4W | | |
| | R 337 | QRE141J-753Y | C RESISTOR | 75K 5% 1/4W | | | △ | R 742 | QRJ146J-100X | UNF C RESISTOR | 10 5% 1/4W | |
| | R 338 | QRJ146J-122X | UNF C RESISTOR | 1.2K 5% 1/4W | | | R 743 | QRE141J-102Y | C RESISTOR | 1.0K 5% 1/4W | | |
| | R 339 | QRJ146J-100X | UNF C RESISTOR | 10 5% 1/4W | | | R 744 | QRE141J-102Y | C RESISTOR | 1.0K 5% 1/4W | | |
| | R 340 | QRE141J-101Y | C RESISTOR | 100 5% 1/4W | | | R 745 | QRE141J-103Y | C RESISTOR | 10K 5% 1/4W | | |
| | R 341 | QRE141J-333Y | C RESISTOR | 33K 5% 1/4W | | | R 746 | QRE141J-103Y | C RESISTOR | 10K 5% 1/4W | | |
| | R 342 | QRE141J-101Y | C RESISTOR | 100 5% 1/4W | | | R 747 | QRE141J-103Y | C RESISTOR | 10K 5% 1/4W | | |
| | R 343 | QRE141J-473Y | C RESISTOR | 47K 5% 1/4W | | | R 748 | QRE141J-103Y | C RESISTOR | 10K 5% 1/4W | | |
| | R 344 | QRE141J-183Y | C RESISTOR | 18K 5% 1/4W | | | R 749 | QRE141J-202Y | C RESISTOR | 2.0K 5% 1/4W | | |
| | R 346 | QRT01DJ-R22X | MF RESISTOR | 5% 1W | | | R 750 | QRE141J-202Y | C RESISTOR | 2.0K 5% 1/4W | | |
| | R 348 | QRT01DJ-R22X | MF RESISTOR | 5% 1W | | | R 751 | QRJ146J-101X | UNF C RESISTOR | 100 5% 1/4W | | |
| | R 350 | QRT01DJ-R22X | MF RESISTOR | 5% 1W | | | R 752 | QRJ146J-101X | UNF C RESISTOR | 100 5% 1/4W | | |
| | R 351 | QRE141J-183Y | C RESISTOR | 18K 5% 1/4W | | | R 753 | QRE141J-563Y | C RESISTOR | 56K 5% 1/4W | | |
| | R 352 | QRE141J-102Y | C RESISTOR | 1.0K 5% 1/4W | | | R 754 | QRE141J-563Y | C RESISTOR | 56K 5% 1/4W | | |
| | R 353 | QRE141J-473Y | C RESISTOR | 47K 5% 1/4W | | | R 755 | QRJ146J-122X | UNF C RESISTOR | 1.2K 5% 1/4W | | |
| | R 354 | QRE141J-183Y | C RESISTOR | 18K 5% 1/4W | | | R 756 | QRJ146J-122X | UNF C RESISTOR | 1.2K 5% 1/4W | | |
| | R 355 | QRE141J-102Y | C RESISTOR | 1.0K 5% 1/4W | | | R 757 | QRE141J-563Y | C RESISTOR | 56K 5% 1/4W | | |
| | R 356 | QRE141J-473Y | C RESISTOR | 47K 5% 1/4W | | | R 758 | QRE141J-563Y | C RESISTOR | 56K 5% 1/4W | | |
| | R 357 | QRE141J-102Y | C RESISTOR | 1.0K 5% 1/4W | | | R 759 | QRJ146J-100X | UNF C RESISTOR | 10 5% 1/4W | | |
| | R 358 | QRE141J-102Y | C RESISTOR | 1.0K 5% 1/4W | | | R 760 | QRJ146J-100X | UNF C RESISTOR | 10 5% 1/4W | | |
| | R 360 | QRE141J-104Y | C RESISTOR | 100K 5% 1/4W | | | R 761 | QRJ146J-100X | UNF C RESISTOR | 10 5% 1/4W | | |
| | R 361 | QRE141J-104Y | C RESISTOR | 100K 5% 1/4W | | | R 762 | QRJ146J-100X | UNF C RESISTOR | 10 5% 1/4W | | |
| | R 362 | QRE141J-104Y | C RESISTOR | 100K 5% 1/4W | | | R 763 | QRE141J-221Y | C RESISTOR | 220 5% 1/4W | | |
| | R 701 | QRJ146J-470X | UNF C RESISTOR | 47 5% 1/4W | | | R 764 | QRE141J-221Y | C RESISTOR | 220 5% 1/4W | | |
| | R 702 | QRJ146J-470X | UNF C RESISTOR | 47 5% 1/4W | | | R 765 | QRE141J-222Y | C RESISTOR | 2.2K 5% 1/4W | | |
| | R 703 | QRE141J-563Y | C RESISTOR | 56K 5% 1/4W | | | R 766 | QRE141J-222Y | C RESISTOR | 2.2K 5% 1/4W | | |
| | R 704 | QRE141J-563Y | C RESISTOR | 56K 5% 1/4W | | | R 767 | QRE141J-103Y | C RESISTOR | 10K 5% 1/4W | | |
| | R 705 | QRJ146J-821X | UNF C RESISTOR | 820 5% 1/4W | | | R 768 | QRE141J-103Y | C RESISTOR | 10K 5% 1/4W | | |

■ Electrical parts list (Power board)

Block No. 01

| △ | Item | Parts number | Parts name | Remarks | Area |
|---|-------|--------------|----------------|--------------|------|
| | R 769 | QRL01DJ-821X | OMF RESISTOR | 820 5% 1/1W | |
| | R 770 | QRL01DJ-821X | OMF RESISTOR | 820 5% 1/1W | |
| | R 774 | QRE141J-333Y | C RESISTOR | 33K 5% 1/4W | |
| | R 775 | QRE141J-103Y | C RESISTOR | 10K 5% 1/4W | |
| | R 776 | QRE141J-103Y | C RESISTOR | 10K 5% 1/4W | |
| △ | R 777 | QRJ146J-100X | UNF C RESISTOR | 10 5% 1/4W | |
| | R 778 | QRE141J-102Y | C RESISTOR | 1.0K 5% 1/4W | |
| | R 779 | QRE141J-102Y | C RESISTOR | 1.0K 5% 1/4W | |
| | R 784 | QRT01DJ-R22X | MF RESISTOR | 5% 1W | |
| | R 786 | QRT01DJ-R22X | MF RESISTOR | 5% 1W | |
| | R 787 | QRE141J-202Y | C RESISTOR | 2.0K 5% 1/4W | |
| | R 788 | QRE141J-202Y | C RESISTOR | 2.0K 5% 1/4W | |
| | RY201 | QSK0109-001 | RELAY | | |
| | RY202 | QSK0109-001 | RELAY | | |

■ Electrical parts list (Main board)

Block No. 02

| △ | Item | Parts number | Parts name | Remarks | Area | △ | Item | Parts number | Parts name | Remarks | Area |
|---|-------|----------------|----------------|----------------|------|---|-------|----------------|--------------|---------------|------|
| | C 402 | QCZ0202-155Z | ML C CAPACITOR | 1.5MF | | | C 548 | EETC1AM-227ZJC | E CAPACITOR | | |
| | C 404 | QCZ0202-155Z | ML C CAPACITOR | 1.5MF | | | C 549 | NCF31CZ-104X | C CAPACITOR | | |
| | C 405 | EETC0JM-477ZJC | C CAPACITOR | | | | C 550 | QETN1EM-106Z | E CAPACITOR | 10MF 20% 25V | |
| | C 408 | QCZ0202-155Z | ML C CAPACITOR | 1.5MF | | | C 560 | QTE1C06-476Z | E CAPACITOR | | |
| | C 409 | EETC1AM-477ZJC | E CAPACITOR | | | | C 561 | QETN1EM-106Z | E CAPACITOR | 10MF 20% 25V | |
| | C 410 | NCB31HK-103X | C CAPACITOR | | | | C 562 | EETC1HM-225ZJC | E CAPACITOR | | |
| | C 411 | NCB31AK-224X | C CAPACITOR | | | | C 563 | QETN1EM-106Z | E CAPACITOR | 10MF 20% 25V | |
| | C 413 | QCZ0202-155Z | ML C CAPACITOR | 1.5MF | | | C 564 | QETN1CM-476Z | E CAPACITOR | 47MF 20% 16V | |
| | C 414 | EETC0JM-477ZJC | C CAPACITOR | | | | C 565 | QETN1EM-106Z | E CAPACITOR | 10MF 20% 25V | |
| | C 420 | QDXB1CM-182Y | C CAPACITOR | | | | C 566 | NCB31CK-563X | C CAPACITOR | | |
| | C 421 | QCSB1HJ-330Y | C CAPACITOR | 33PF 5% 50V | | | C 567 | NCB31AK-224X | C CAPACITOR | | |
| | C 422 | QDVB1EZ-223Y | C CAPACITOR | | | | C 568 | QETN1EM-106Z | E CAPACITOR | 10MF 20% 25V | |
| | C 423 | QDGB1HK-681Y | C CAPACITOR | | | | C 580 | QETN1CM-106Z | E CAPACITOR | 10MF 20% 16V | |
| | C 424 | EETC1HM-105ZJC | E CAPACITOR | | | | C 600 | NCS31HJ-101X | C CAPACITOR | | |
| | C 425 | EETC1AM-107ZJC | E CAPACITOR | | | | C 601 | EETC1HM-106ZJC | E CAPACITOR | | |
| | C 430 | NCB31HK-102X | C CAPACITOR | | | | C 602 | EETC1HM-106ZJC | E CAPACITOR | | |
| | C 431 | NCB31CK-333X | C CAPACITOR | | | | C 603 | EETC1HM-225ZJC | E CAPACITOR | | |
| | C 432 | EETC1AM-107ZJC | E CAPACITOR | | | | C 604 | EETC1HM-225ZJC | E CAPACITOR | | |
| | C 433 | NCB31HK-221X | C CAPACITOR | | | | C 605 | EETC1EM-106ZJC | E CAPACITOR | | |
| | C 434 | NCB31HK-681X | C CAPACITOR | | | | C 606 | EETC1EM-106ZJC | E CAPACITOR | | |
| | C 437 | NCB31HK-103X | C CAPACITOR | | | | C 607 | EETC1EM-106ZJC | E CAPACITOR | | |
| | C 450 | NCB31HK-102X | C CAPACITOR | | | | C 608 | EETC1EM-106ZJC | E CAPACITOR | | |
| | C 451 | NCB31CK-333X | C CAPACITOR | | | | C 609 | EETC1HM-106ZJC | E CAPACITOR | | |
| | C 452 | EETC1AM-107ZJC | E CAPACITOR | | | | C 610 | EETC1HM-106ZJC | E CAPACITOR | | |
| | C 453 | NCB31HK-221X | C CAPACITOR | | | | C 611 | EETC1HM-225ZJC | E CAPACITOR | | |
| | C 454 | NCB31HK-681X | C CAPACITOR | | | | C 612 | EETC1HM-225ZJC | E CAPACITOR | | |
| | C 457 | NCB31HK-103X | C CAPACITOR | | | | C 613 | NCB31HK-102X | C CAPACITOR | | |
| | C 500 | EETC1AM-477ZJC | E CAPACITOR | | | | C 614 | NCB31HK-102X | C CAPACITOR | | |
| | C 501 | NCS31HJ-470X | C CAPACITOR | | | | C 615 | NCB31HK-103X | C CAPACITOR | | |
| | C 502 | NCS31HJ-221X | C CAPACITOR | | | | C 616 | NCB31HK-103X | C CAPACITOR | | |
| | C 503 | NCS31HJ-471X | C CAPACITOR | | | | C 617 | NCB31HK-103X | C CAPACITOR | | |
| | C 504 | EETC1AM-477ZJC | E CAPACITOR | | | | C 618 | NCB31HK-103X | C CAPACITOR | | |
| | C 505 | NCS31HJ-470X | C CAPACITOR | | | | C 619 | EETC1HM-106ZJC | E CAPACITOR | | |
| | C 506 | NCS31HJ-221X | C CAPACITOR | | | | C 620 | NCS31HJ-101X | C CAPACITOR | | |
| | C 507 | NCS31HJ-471X | C CAPACITOR | | | | C 621 | EETC1HM-475ZJC | E CAPACITOR | | |
| | C 508 | NCB31CK-104X | C CAPACITOR | | | | C 622 | EETC1HM-475ZJC | E CAPACITOR | | |
| | C 509 | NCS31HJ-470X | C CAPACITOR | | | | C 623 | QETN1HM-475Z | E CAPACITOR | 4.7MF 20% 50V | |
| | C 510 | NCS31HJ-221X | C CAPACITOR | | | | C 625 | QETN1AM-107Z | E CAPACITOR | 100MF 20% 10V | |
| | C 511 | NCS31HJ-471X | C CAPACITOR | | | | C 626 | EETC1HM-475ZJC | E CAPACITOR | | |
| | C 515 | QFLC1HJ-223Z | M CAPACITOR | .022MF 5% 50V | | | C 627 | QFVJ1HJ-274Z | MF CAPACITOR | .27MF 5% 50V | |
| | C 516 | QFLC1HJ-223Z | M CAPACITOR | .022MF 5% 50V | | | C 628 | QFLC1HJ-822Z | M CAPACITOR | 8200PF 5% 50V | |
| | C 517 | QFG32AJ-223Z | PP CAPACITOR | .022MF 5% 100V | | | C 629 | QFLC1HJ-153Z | M CAPACITOR | .015MF 5% 50V | |
| | C 518 | QFG32AJ-223Z | PP CAPACITOR | .022MF 5% 100V | | | C 630 | QFV61HJ-823Z | MF CAPACITOR | .082MF 5% 50V | |
| | C 519 | EETC1EM-106ZJC | E CAPACITOR | | | | C 631 | QFVJ1HJ-224Z | MF CAPACITOR | .22MF 5% 50V | |
| | C 520 | EETC1EM-106ZJC | E CAPACITOR | | | | C 632 | QFLC1HJ-273Z | M CAPACITOR | .027MF 5% 50V | |
| | C 521 | NCS31HJ-100X | C CAPACITOR | | | | C 633 | EETC1HM-225ZJC | E CAPACITOR | | |
| | C 522 | NCS31HJ-100X | C CAPACITOR | | | | C 634 | NCS31HJ-101X | C CAPACITOR | | |
| | C 525 | EETC1HM-105ZJC | E CAPACITOR | | | | C 635 | QETN1CM-476Z | E CAPACITOR | 47MF 20% 16V | |
| | C 526 | QFLC1HJ-223Z | M CAPACITOR | .022MF 5% 50V | | | C 636 | QETN1CM-476Z | E CAPACITOR | 47MF 20% 16V | |
| | C 527 | QDGB1HK-102Y | C CAPACITOR | | | | C 637 | EETC1HM-105ZJC | E CAPACITOR | | |
| | C 528 | FQCF31HP-103Z | C CAPACITOR | | | | C 638 | QTE1C06-476Z | E CAPACITOR | | |
| | C 531 | NCB31HK-221X | C CAPACITOR | | | | C 640 | QFVJ1HJ-683Z | MF CAPACITOR | .068MF 5% 50V | |
| | C 532 | NCB31HK-221X | C CAPACITOR | | | | C 641 | NCB31CK-183X | C CAPACITOR | | |
| | C 533 | NCB31HK-221X | C CAPACITOR | | | | C 642 | EETC1AM-107ZJC | E CAPACITOR | | |
| | C 534 | NCB31HK-221X | C CAPACITOR | | | | C 643 | EEKC1CM-476ZJC | E CAPACITOR | | |
| | C 535 | NCB31HK-222X | C CAPACITOR | | | | C 644 | NCF31CZ-104X | C CAPACITOR | | |
| | C 536 | NCB31HK-222X | C CAPACITOR | | | | C 645 | NCF31CZ-104X | C CAPACITOR | | |
| | C 542 | QETN1AM-477Z | E CAPACITOR | 470MF 20% 10V | | | C 650 | EETC1CM-106ZJC | E CAPACITOR | | |
| | C 543 | EETC1AM-107ZJC | E CAPACITOR | | | | C 651 | EETC1CM-106ZJC | E CAPACITOR | | |
| | C 544 | NCF31CZ-104X | C CAPACITOR | | | | C 652 | EETC1CM-106ZJC | E CAPACITOR | | |
| | C 545 | EETC1AM-107ZJC | E CAPACITOR | | | | C 655 | EETC1HM-105ZJC | E CAPACITOR | | |
| | C 546 | NCF31CZ-104X | C CAPACITOR | | | | C 656 | EETC1HM-105ZJC | E CAPACITOR | | |
| | C 547 | NCB31HK-331X | C CAPACITOR | | | | C 657 | EETC1HM-106ZJC | E CAPACITOR | | |

■ Electrical parts list (Main board)

Block No. 02

| ▲ | Item | Parts number | Parts name | Remarks | Area | ▲ | Item | Parts number | Parts name | Remarks | Area |
|---|-------|----------------|----------------|---------------|------|---|-------|----------------|----------------|---------|------|
| | C 660 | EETC1CM-476ZJC | E CAPACITOR | | | | C1563 | QDGB1HK-103Y | C CAPACITOR | | |
| | C 661 | EETC1CM-106ZJC | E CAPACITOR | | | | C1564 | EETC0JM-477ZJC | C CAPACITOR | | |
| | C 666 | EETC1CM-476ZJC | E CAPACITOR | | | | C1565 | EETC0JM-477ZJC | C CAPACITOR | | |
| | C 667 | EETC1HM-105ZJC | E CAPACITOR | | | | C1566 | EETC0JM-477ZJC | C CAPACITOR | | |
| | C 668 | EETC1HM-106ZJC | E CAPACITOR | | | | C1567 | NCB31HK-103X | C CAPACITOR | | |
| | C 670 | EETC1HM-224ZJC | E CAPACITOR | | | | C1568 | NCB31AK-224X | C CAPACITOR | | |
| | C 671 | EETC1HM-105ZJC | E CAPACITOR | | | | C1574 | EETC1HM-105ZJC | E CAPACITOR | | |
| | C 672 | EETC1HM-105ZJC | E CAPACITOR | | | | C1580 | QCZ0202-155Z | ML C CAPACITOR | 1.5MF | |
| | C 673 | EETC1CM-227ZJC | E CAPACITOR | | | | C1581 | QCZ0202-155Z | ML C CAPACITOR | 1.5MF | |
| | C 674 | NCB31HK-472X | C CAPACITOR | | | | C1582 | QCZ0202-155Z | ML C CAPACITOR | 1.5MF | |
| | C 675 | QETN1HM-225Z | E CAPACITOR | 2.2MF 20% 50V | | | C1583 | QCZ0202-155Z | ML C CAPACITOR | 1.5MF | |
| | C 678 | EETC1HM-224ZJC | E CAPACITOR | | | | C1584 | EETC0JM-477ZJC | C CAPACITOR | | |
| | C 679 | NCB31CK-683X | C CAPACITOR | | | | C1585 | EETC0JM-477ZJC | C CAPACITOR | | |
| | C 680 | NCB31HK-472X | C CAPACITOR | | | | C1586 | EETC0JM-477ZJC | C CAPACITOR | | |
| | C 681 | NCB31CK-683X | C CAPACITOR | | | | C1587 | NCB31HK-103X | C CAPACITOR | | |
| | C 682 | EETC1CM-227ZJC | E CAPACITOR | | | | C1588 | NCB31AK-224X | C CAPACITOR | | |
| | CN500 | QGF1205C1-17 | CONNECTOR | | | | C1590 | NCF31CZ-104X | C CAPACITOR | | |
| | CN505 | QGF1205C1-14 | CONNECTOR | | | | C1591 | NCF31CZ-104X | C CAPACITOR | | |
| | CN510 | QGF1205C1-10 | CONNECTOR | | | | C1592 | NCF31CZ-104X | C CAPACITOR | | |
| | CN513 | QGD2504C1-04Z | SOCKET | | | | C1593 | NCF31CZ-104X | C CAPACITOR | | |
| | CN521 | QGB1214J1-14S | CONNECTOR | | | | D 420 | 1SS119-041-T2 | SI DIODE | | |
| | CN530 | QGB2510K2-09 | CONNECTOR | | | | D 421 | DZ5.1BSB-T2 | ZENER DIODE | | |
| | CN531 | QGB2510K2-08 | CONNECTOR | | | | D 500 | 1SS119-041-T2 | SI DIODE | | |
| | CN540 | QGF1016C1-09 | CONNECTOR | | | | D 501 | 1SS119-041-T2 | SI DIODE | | |
| | CN541 | QGF1016C1-17 | CONNECTOR | | | | D 502 | 1SS119-041-T2 | SI DIODE | | |
| | CN542 | QGF1205F1-10 | CONNECTOR | | | | D 531 | 1SS119-041-T2 | SI DIODE | | |
| | CN550 | QGF1205F1-09 | CONNECTOR | | | | D 532 | 1SS119-041-T2 | SI DIODE | | |
| | C1400 | EETC1CM-227ZJC | E CAPACITOR | | | | D 533 | 1SS119-041-T2 | SI DIODE | | |
| | C1401 | NCB31HK-471X | C CAPACITOR | | | | D 534 | 1SS119-041-T2 | SI DIODE | | |
| | C1405 | QDGB1HK-102Y | C CAPACITOR | | | | D 545 | 1SS119-041-T2 | SI DIODE | | |
| | C1406 | QDGB1HK-102Y | C CAPACITOR | | | | D 546 | DZ3.9BSB-T2 | ZENER DIODE | | |
| | C1408 | QDGB1HK-102Y | C CAPACITOR | | | | D 547 | DZ3.9BSB-T2 | ZENER DIODE | | |
| | C1409 | QDGB1HK-103Y | C CAPACITOR | | | | D 600 | 1SS119-041-T2 | SI DIODE | | |
| | C1410 | NCS31HJ-470X | C CAPACITOR | | | | D 601 | 1SS119-041-T2 | SI DIODE | | |
| | C1411 | NCS31HJ-470X | C CAPACITOR | | | | D 605 | 1SS119-041-T2 | SI DIODE | | |
| | C1412 | NCS31HJ-470X | C CAPACITOR | | | | D 606 | 1SS119-041-T2 | SI DIODE | | |
| | C1501 | EETC1AM-107ZJC | E CAPACITOR | | | | D1401 | 1SS119-041-T2 | SI DIODE | | |
| | C1502 | NCB31HK-123X | C CAPACITOR | | | | D1402 | 1SS119-041-T2 | SI DIODE | | |
| | C1503 | NCB31HK-152X | C CAPACITOR | | | | D1403 | DZ3.9BSB-T2 | ZENER DIODE | | |
| | C1504 | NCS31HJ-101X | C CAPACITOR | | | | D1406 | 1SS119-041-T2 | SI DIODE | | |
| | C1505 | NCB31CK-333X | C CAPACITOR | | | | IC500 | MN101C49GEH1 | IC | | |
| | C1506 | NCB31HK-102X | C CAPACITOR | | | | IC501 | MN35505-X | IC | | |
| | C1507 | NCB31HK-123X | C CAPACITOR | | | | IC502 | MN35505-X | IC | | |
| | C1508 | NCB31HK-152X | C CAPACITOR | | | | IC503 | MN35505-X | IC | | |
| | C1509 | NCS31HJ-101X | C CAPACITOR | | | | IC511 | BA15218F-XE | IC | | |
| | C1510 | NCB31CK-333X | C CAPACITOR | | | | IC512 | BA15218F-XE | IC | | |
| | C1511 | NCB31HK-102X | C CAPACITOR | | | | IC513 | BA15218F-XE | IC | | |
| | C1513 | EETC1AM-107ZJC | E CAPACITOR | | | | IC514 | BA15218F-XE | IC | | |
| | C1531 | EETC1AM-107ZJC | E CAPACITOR | | | | IC515 | BA15218F-XE | IC | | |
| | C1532 | NCB31HK-123X | C CAPACITOR | | | | IC516 | BA15218F-XE | IC | | |
| | C1533 | NCB31HK-152X | C CAPACITOR | | | | IC521 | LC75345M-X | IC | | |
| | C1534 | NCS31HJ-101X | C CAPACITOR | | | | IC522 | LC75342M-X | IC | | |
| | C1535 | NCB31CK-333X | C CAPACITOR | | | | IC523 | LC75342M-X | IC | | |
| | C1536 | NCB31HK-102X | C CAPACITOR | | | | IC531 | BA15218F-XE | IC | | |
| | C1537 | NCB31HK-123X | C CAPACITOR | | | | IC532 | BA15218F-XE | IC | | |
| | C1538 | NCB31HK-152X | C CAPACITOR | | | | IC533 | BA15218F-XE | IC | | |
| | C1539 | NCS31HJ-101X | C CAPACITOR | | | | IC534 | BA15218F-XE | IC | | |
| | C1540 | NCB31CK-333X | C CAPACITOR | | | | IC535 | BA15218F-XE | IC | | |
| | C1541 | NCB31HK-102X | C CAPACITOR | | | | IC536 | BA15218F-XE | IC | | |
| | C1543 | EETC1AM-107ZJC | E CAPACITOR | | | | IC550 | LV1100 | IC | | |
| | C1560 | QCZ0202-155Z | ML C CAPACITOR | 1.5MF | | | IC560 | BA3838F-X | IC | | |
| | C1561 | QCZ0202-155Z | ML C CAPACITOR | 1.5MF | | | J 500 | QNZ0430-001 | AV JACK | | |
| | C1562 | QCZ0202-155Z | ML C CAPACITOR | 1.5MF | | | J 501 | QNN0167-001 | PIN JACK | | |

■ Electrical parts list (Main board)

Block No. 02

| △ | Item | Parts number | Parts name | Remarks | Area | △ | Item | Parts number | Parts name | Remarks | Area |
|---|-------|---------------|---------------|-------------|------|---|-------|--------------|----------------|--------------|------|
| | J 502 | QNS0009-001 | 3.5 JACK | | | | R 411 | QRE141J-101Y | C RESISTOR | 100 5% 1/4W | |
| | K 401 | NQR0428-002X | F.BEADS | | | | R 412 | NRSA63J-104X | MG RESISTOR | | |
| | K 402 | NQR0428-002X | F.BEADS | | | | R 413 | NRSA63J-104X | MG RESISTOR | | |
| | K 403 | NQR0428-002X | F.BEADS | | | | R 414 | NRSA63J-104X | MG RESISTOR | | |
| | K 404 | NQR0428-002X | F.BEADS | | | | R 420 | NRSA63J-473X | MG RESISTOR | | |
| | K 420 | QQR1277-001Z | F.BEADS | | | | R 421 | QRE141J-225Y | C RESISTOR | 2.2M 5% 1/4W | |
| | K 421 | QQR1277-001Z | F.BEADS | | | | R 422 | QRE141J-220Y | C RESISTOR | 22 5% 1/4W | |
| | K 422 | QQR1277-001Z | F.BEADS | | | | R 423 | NRSA63J-104X | MG RESISTOR | | |
| | K 423 | QQR1277-001Z | F.BEADS | | | | R 424 | QRJ146J-4R7X | UNF C RESISTOR | 4.7 5% 1/4W | |
| | K 424 | QQR1277-001Z | F.BEADS | | | | R 430 | NRSA63J-273X | MG RESISTOR | | |
| | K 425 | QQR1277-001Z | F.BEADS | | | | R 431 | NRSA63J-273X | MG RESISTOR | | |
| | K 429 | QQR1277-001Z | F.BEADS | | | | R 432 | NRSA63J-183X | MG RESISTOR | | |
| | K 430 | QQR1277-001Z | F.BEADS | | | | R 433 | NRSA63J-183X | MG RESISTOR | | |
| | K 532 | QQR1277-001Z | F.BEADS | | | | R 434 | NRSA63J-362X | MG RESISTOR | | |
| | K1561 | NQR0428-002X | F.BEADS | | | | R 435 | NRSA63J-183X | MG RESISTOR | | |
| | K1562 | NQR0428-002X | F.BEADS | | | | R 436 | NRSA63J-332X | MG RESISTOR | | |
| | K1580 | NQR0428-002X | F.BEADS | | | | R 437 | NRSA63J-362X | MG RESISTOR | | |
| | K1581 | NQR0428-002X | F.BEADS | | | | R 440 | NRSA63J-112X | MG RESISTOR | | |
| | L 500 | QQL231K-2R2Y | INDUCTOR | | | | R 441 | NRSA63J-681X | MG RESISTOR | | |
| | L 501 | QQL231K-5R6Y | INDUCTOR | | | | R 442 | NRSA63J-112X | MG RESISTOR | | |
| | L 502 | QQL231K-2R2Y | INDUCTOR | | | | R 443 | NRSA63J-183X | MG RESISTOR | | |
| | L 503 | QQL231K-5R6Y | INDUCTOR | | | | R 450 | NRSA63J-273X | MG RESISTOR | | |
| | L 504 | QQL231K-2R2Y | INDUCTOR | | | | R 451 | NRSA63J-273X | MG RESISTOR | | |
| | L 505 | QQL231K-5R6Y | INDUCTOR | | | | R 452 | NRSA63J-183X | MG RESISTOR | | |
| | L 506 | QQL231K-2R2Y | INDUCTOR | | | | R 453 | NRSA63J-183X | MG RESISTOR | | |
| | L 507 | QQL231K-2R2Y | INDUCTOR | | | | R 454 | NRSA63J-362X | MG RESISTOR | | |
| | L 545 | QQL231K-2R2Y | INDUCTOR | | | | R 455 | NRSA63J-183X | MG RESISTOR | | |
| | Q 420 | 2SC2812N/6/-X | SI.TRANSISTOR | | | | R 456 | NRSA63J-332X | MG RESISTOR | | |
| | Q 421 | 2SC2812N/6/-X | SI.TRANSISTOR | | | | R 457 | NRSA63J-362X | MG RESISTOR | | |
| | Q 500 | 2SB709A/QR/-X | TRANSISTOR | | | | R 460 | NRSA63J-112X | MG RESISTOR | | |
| | Q 501 | 2SB709A/QR/-X | TRANSISTOR | | | | R 461 | NRSA63J-681X | MG RESISTOR | | |
| | Q 502 | 2SB709A/QR/-X | TRANSISTOR | | | | R 462 | NRSA63J-112X | MG RESISTOR | | |
| | Q 505 | 2SB709A/QR/-X | TRANSISTOR | | | | R 463 | NRSA63J-183X | MG RESISTOR | | |
| | Q 506 | UN2214-X | TRANSISTOR | | | | R 470 | NRSA63J-472X | MG RESISTOR | | |
| | Q 507 | UN2111-X | TRANSISTOR | | | | R 471 | NRSA63J-472X | MG RESISTOR | | |
| | Q 515 | UN2111-X | TRANSISTOR | | | | R 472 | NRSA63J-472X | MG RESISTOR | | |
| | Q 516 | 2SC2812N/6/-X | SI.TRANSISTOR | | | | R 500 | QRE141J-680Y | C RESISTOR | 68 5% 1/4W | |
| | Q 517 | 2SC2812N/6/-X | SI.TRANSISTOR | | | | R 501 | NRSA63J-221X | MG RESISTOR | | |
| | Q 531 | 2SC2812N/6/-X | SI.TRANSISTOR | | | | R 502 | NRSA63J-151X | MG RESISTOR | | |
| | Q 532 | 2SC2812N/6/-X | SI.TRANSISTOR | | | | R 503 | NRSA63J-151X | MG RESISTOR | | |
| | Q 534 | 2SC2812N/6/-X | SI.TRANSISTOR | | | | R 504 | QRE141J-561Y | C RESISTOR | 560 5% 1/4W | |
| | Q 535 | 2SC2812N/6/-X | SI.TRANSISTOR | | | | R 505 | NRSA63J-750X | MG RESISTOR | | |
| | Q 541 | UN2111-X | TRANSISTOR | | | | R 506 | NRSA63J-221X | MG RESISTOR | | |
| | Q 545 | UN2214-X | TRANSISTOR | | | | R 507 | NRSA63J-151X | MG RESISTOR | | |
| | Q 546 | 2SC2812N/6/-X | SI.TRANSISTOR | | | | R 508 | NRSA63J-151X | MG RESISTOR | | |
| | Q 547 | 2SC2812N/6/-X | SI.TRANSISTOR | | | | R 509 | QRE141J-561Y | C RESISTOR | 560 5% 1/4W | |
| | Q 548 | 2SC2812N/6/-X | SI.TRANSISTOR | | | | R 510 | NRSA63J-750X | MG RESISTOR | | |
| | Q 549 | 2SC2812N/6/-X | SI.TRANSISTOR | | | | R 511 | NRSA63J-221X | MG RESISTOR | | |
| | Q 550 | 2SC2812N/6/-X | SI.TRANSISTOR | | | | R 512 | NRSA63J-151X | MG RESISTOR | | |
| | Q 551 | 2SC2812N/6/-X | SI.TRANSISTOR | | | | R 513 | NRSA63J-151X | MG RESISTOR | | |
| | Q 600 | 2SC2812N/6/-X | SI.TRANSISTOR | | | | R 514 | QRE141J-561Y | C RESISTOR | 560 5% 1/4W | |
| | Q 601 | 2SC2812N/6/-X | SI.TRANSISTOR | | | | R 515 | NRSA63J-563X | MG RESISTOR | | |
| | Q 602 | 2SC2812N/6/-X | SI.TRANSISTOR | | | | R 516 | NRSA63J-563X | MG RESISTOR | | |
| | Q1574 | 2SC2812N/6/-X | SI.TRANSISTOR | | | | R 517 | NRSA63J-222X | MG RESISTOR | | |
| | R 401 | QRE141J-470Y | C RESISTOR | 47 5% 1/4W | | | R 518 | NRSA63J-222X | MG RESISTOR | | |
| | R 402 | NRSA63J-471X | MG RESISTOR | | | | R 521 | NRSA63J-154X | MG RESISTOR | | |
| | R 403 | NRSA63J-471X | MG RESISTOR | | | | R 522 | NRSA63J-154X | MG RESISTOR | | |
| | R 404 | NRSA63J-471X | MG RESISTOR | | | | R 525 | QRE141J-563Y | C RESISTOR | 56K 5% 1/4W | |
| | R 405 | NRSA63J-471X | MG RESISTOR | | | | R 526 | QRE141J-563Y | C RESISTOR | 56K 5% 1/4W | |
| | R 406 | QRE141J-101Y | C RESISTOR | 100 5% 1/4W | | | R 527 | NRSA63J-221X | MG RESISTOR | | |
| | R 408 | NRSA63J-471X | MG RESISTOR | | | | R 528 | NRSA63J-222X | MG RESISTOR | | |
| | R 409 | NRSA63J-471X | MG RESISTOR | | | | R 529 | NRSA63J-222X | MG RESISTOR | | |
| | R 410 | NRSA63J-332X | MG RESISTOR | | | | R 531 | NRSA63J-103X | MG RESISTOR | | |

■ Electrical parts list (Main board)

Block No. 02

| ▲ | Item | Parts number | Parts name | Remarks | Area | ▲ | Item | Parts number | Parts name | Remarks | Area |
|---|-------|--------------|-------------|--------------|------|---|-------|--------------|-------------|--------------|------|
| | R 532 | NRSA63J-103X | MG RESISTOR | | | | R 619 | NRSA63J-563X | MG RESISTOR | | |
| | R 533 | NRSA63J-683X | MG RESISTOR | | | | R 620 | QRE141J-102Y | C RESISTOR | 1.0K 5% 1/4W | |
| | R 534 | NRSA63J-683X | MG RESISTOR | | | | R 621 | QRE141J-822Y | C RESISTOR | 8.2K 5% 1/4W | |
| | R 535 | NRSA63J-201X | MG RESISTOR | | | | R 622 | QRE141J-823Y | C RESISTOR | 82K 5% 1/4W | |
| | R 536 | NRSA63J-201X | MG RESISTOR | | | | R 623 | QRE141J-271Y | C RESISTOR | 270 5% 1/4W | |
| | R 537 | NRSA63J-222X | MG RESISTOR | | | | R 624 | QRE141J-473Y | C RESISTOR | 47K 5% 1/4W | |
| | R 538 | NRSA63J-222X | MG RESISTOR | | | | R 625 | NRSA63J-473X | MG RESISTOR | | |
| | R 539 | NRSA63J-472X | MG RESISTOR | | | | R 626 | NRSA63J-104X | MG RESISTOR | | |
| | R 540 | NRSA63J-472X | MG RESISTOR | | | | R 627 | NRSA63J-104X | MG RESISTOR | | |
| | R 541 | NRSA63J-272X | MG RESISTOR | | | | R 628 | QRE141J-184Y | C RESISTOR | 180K 5% 1/4W | |
| | R 543 | NRSA63J-102X | MG RESISTOR | | | | R 629 | QRE141J-153Y | C RESISTOR | 15K 5% 1/4W | |
| | R 544 | NRSA63J-102X | MG RESISTOR | | | | R 630 | NRSA63J-224X | MG RESISTOR | | |
| | R 545 | NRSA63J-222X | MG RESISTOR | | | | R 631 | NRSA63J-101X | MG RESISTOR | | |
| | R 546 | NRSA63J-222X | MG RESISTOR | | | | R 632 | NRSA63J-101X | MG RESISTOR | | |
| | R 547 | QRE141J-102Y | C RESISTOR | 1.0K 5% 1/4W | | | R 634 | NRSA63J-113X | MG RESISTOR | | |
| | R 548 | NRSA63J-472X | MG RESISTOR | | | | R 635 | NRSA63J-223X | MG RESISTOR | | |
| | R 549 | NRSA63J-472X | MG RESISTOR | | | | R 636 | NRSA63J-562X | MG RESISTOR | | |
| | R 553 | NRSA63J-105X | MG RESISTOR | | | | R 637 | NRSA63J-472X | MG RESISTOR | | |
| | R 554 | NRSA63J-103X | MG RESISTOR | | | | R 638 | NRSA63J-203X | MG RESISTOR | | |
| | R 555 | NRSA63J-103X | MG RESISTOR | | | | R 639 | NRSA63J-223X | MG RESISTOR | | |
| | R 556 | NRSA63J-221X | MG RESISTOR | | | | R 641 | QRE141J-124Y | C RESISTOR | 120K 5% 1/4W | |
| | R 557 | NRSA63J-221X | MG RESISTOR | | | | R 650 | NRSA63J-222X | MG RESISTOR | | |
| | R 558 | NRSA63J-101X | MG RESISTOR | | | | R 651 | NRSA63J-222X | MG RESISTOR | | |
| | R 560 | NRSA63J-123X | MG RESISTOR | | | | R 652 | NRSA63J-222X | MG RESISTOR | | |
| | R 561 | NRSA63J-123X | MG RESISTOR | | | | R 660 | NRSA63J-222X | MG RESISTOR | | |
| | R 562 | NRSA63J-223X | MG RESISTOR | | | | R 661 | NRSA63J-222X | MG RESISTOR | | |
| | R 563 | NRSA63J-472X | MG RESISTOR | | | | R 662 | NRSA63J-222X | MG RESISTOR | | |
| | R 564 | NRSA63J-223X | MG RESISTOR | | | | R 663 | NRSA63J-222X | MG RESISTOR | | |
| | R 565 | NRSA63J-303X | MG RESISTOR | | | | R 670 | NRSA63J-102X | MG RESISTOR | | |
| | R 566 | NRSA63J-222X | MG RESISTOR | | | | R 671 | NRSA63J-102X | MG RESISTOR | | |
| | R 567 | NRSA63J-222X | MG RESISTOR | | | | R 672 | NRSA63J-513X | MG RESISTOR | | |
| | R 568 | NRSA63J-112X | MG RESISTOR | | | | R 673 | NRSA63J-513X | MG RESISTOR | | |
| | R 569 | NRSA63J-222X | MG RESISTOR | | | | R 674 | NRSA63J-105X | MG RESISTOR | | |
| | R 571 | QRE141J-303Y | C RESISTOR | 30K 5% 1/4W | | | R1400 | NRSA63J-103X | MG RESISTOR | | |
| | R 572 | QRE141J-303Y | C RESISTOR | 30K 5% 1/4W | | | R1403 | NRSA63J-112X | MG RESISTOR | | |
| | R 573 | NRSA63J-562X | MG RESISTOR | | | | R1405 | NRSA63J-100X | MG RESISTOR | | |
| | R 574 | NRSA63J-203X | MG RESISTOR | | | | R1406 | NRSA63J-102X | MG RESISTOR | | |
| | R 575 | NRSA63J-562X | MG RESISTOR | | | | R1407 | NRSA63J-102X | MG RESISTOR | | |
| | R 576 | NRSA63J-203X | MG RESISTOR | | | | R1408 | NRSA63J-102X | MG RESISTOR | | |
| | R 577 | NRSA63J-362X | MG RESISTOR | | | | R1409 | NRSA63J-103X | MG RESISTOR | | |
| | R 578 | NRSA63J-362X | MG RESISTOR | | | | R1410 | QRE141J-681Y | C RESISTOR | 680 5% 1/4W | |
| | R 580 | NRSA63J-102X | MG RESISTOR | | | | R1411 | NRSA63J-102X | MG RESISTOR | | |
| | R 582 | NRSA63J-104X | MG RESISTOR | | | | R1412 | NRSA63J-103X | MG RESISTOR | | |
| | R 584 | NRSA63J-0R0X | MG RESISTOR | | | | R1500 | NRSA63J-821X | MG RESISTOR | | |
| | R 585 | NRSA63J-101X | MG RESISTOR | | | | R1501 | NRSA63J-471X | MG RESISTOR | | |
| | R 600 | NRSA63J-752X | MG RESISTOR | | | | R1502 | NRSA63J-183X | MG RESISTOR | | |
| | R 601 | NRSA63J-752X | MG RESISTOR | | | | R1503 | NRSA63J-681X | MG RESISTOR | | |
| | R 602 | NRSA63J-222X | MG RESISTOR | | | | R1504 | NRSA63J-363X | MG RESISTOR | | |
| | R 603 | NRSA63J-222X | MG RESISTOR | | | | R1505 | NRSA63J-102X | MG RESISTOR | | |
| | R 604 | NRSA63J-222X | MG RESISTOR | | | | R1506 | NRSA63J-362X | MG RESISTOR | | |
| | R 605 | NRSA63J-332X | MG RESISTOR | | | | R1507 | NRSA63J-272X | MG RESISTOR | | |
| | R 606 | NRSA63J-332X | MG RESISTOR | | | | R1508 | NRSA63J-183X | MG RESISTOR | | |
| | R 607 | NRSA63J-303X | MG RESISTOR | | | | R1509 | NRSA63J-183X | MG RESISTOR | | |
| | R 608 | NRSA63J-303X | MG RESISTOR | | | | R1510 | NRSA63J-272X | MG RESISTOR | | |
| | R 609 | QRE141J-274Y | C RESISTOR | 270K 5% 1/4W | | | R1511 | NRSA63J-303X | MG RESISTOR | | |
| | R 610 | QRE141J-104Y | C RESISTOR | 100K 5% 1/4W | | | R1512 | NRSA63J-303X | MG RESISTOR | | |
| | R 611 | QRE141J-104Y | C RESISTOR | 100K 5% 1/4W | | | R1514 | NRSA63J-183X | MG RESISTOR | | |
| | R 612 | NRSA63J-224X | MG RESISTOR | | | | R1515 | NRSA63J-821X | MG RESISTOR | | |
| | R 613 | QRE141J-224Y | C RESISTOR | 220K 5% 1/4W | | | R1516 | NRSA63J-471X | MG RESISTOR | | |
| | R 614 | NRSA63J-104X | MG RESISTOR | | | | R1517 | NRSA63J-681X | MG RESISTOR | | |
| | R 615 | NRSA63J-104X | MG RESISTOR | | | | R1518 | NRSA63J-362X | MG RESISTOR | | |
| | R 616 | NRSA63J-223X | MG RESISTOR | | | | R1519 | NRSA63J-363X | MG RESISTOR | | |
| | R 617 | NRSA63J-223X | MG RESISTOR | | | | R1520 | NRSA63J-102X | MG RESISTOR | | |

■ Electrical parts list (Main board)

Block No. 02

| △ | Item | Parts number | Parts name | Remarks | Area |
|---|-------|--------------|-------------|-------------|------|
| | R1521 | NRSA63J-183X | MG RESISTOR | | |
| | R1522 | NRSA63J-183X | MG RESISTOR | | |
| | R1523 | NRSA63J-303X | MG RESISTOR | | |
| | R1524 | NRSA63J-303X | MG RESISTOR | | |
| | R1525 | NRSA63J-272X | MG RESISTOR | | |
| | R1526 | NRSA63J-272X | MG RESISTOR | | |
| | R1530 | NRSA63J-821X | MG RESISTOR | | |
| | R1531 | NRSA63J-471X | MG RESISTOR | | |
| | R1532 | NRSA63J-183X | MG RESISTOR | | |
| | R1533 | NRSA63J-681X | MG RESISTOR | | |
| | R1534 | NRSA63J-363X | MG RESISTOR | | |
| | R1535 | NRSA63J-102X | MG RESISTOR | | |
| | R1536 | NRSA63J-362X | MG RESISTOR | | |
| | R1537 | NRSA63J-272X | MG RESISTOR | | |
| | R1538 | NRSA63J-183X | MG RESISTOR | | |
| | R1539 | NRSA63J-183X | MG RESISTOR | | |
| | R1540 | NRSA63J-272X | MG RESISTOR | | |
| | R1541 | NRSA63J-303X | MG RESISTOR | | |
| | R1542 | NRSA63J-303X | MG RESISTOR | | |
| | R1544 | NRSA63J-183X | MG RESISTOR | | |
| | R1545 | NRSA63J-821X | MG RESISTOR | | |
| | R1546 | NRSA63J-471X | MG RESISTOR | | |
| | R1547 | NRSA63J-681X | MG RESISTOR | | |
| | R1548 | NRSA63J-362X | MG RESISTOR | | |
| | R1549 | NRSA63J-363X | MG RESISTOR | | |
| | R1550 | NRSA63J-102X | MG RESISTOR | | |
| | R1551 | NRSA63J-183X | MG RESISTOR | | |
| | R1552 | NRSA63J-183X | MG RESISTOR | | |
| | R1553 | NRSA63J-303X | MG RESISTOR | | |
| | R1554 | NRSA63J-303X | MG RESISTOR | | |
| | R1555 | NRSA63J-272X | MG RESISTOR | | |
| | R1556 | NRSA63J-272X | MG RESISTOR | | |
| | R1561 | NRSA63J-471X | MG RESISTOR | | |
| | R1562 | NRSA63J-471X | MG RESISTOR | | |
| | R1563 | NRSA63J-471X | MG RESISTOR | | |
| | R1564 | NRSA63J-471X | MG RESISTOR | | |
| | R1565 | QRE141J-470Y | C RESISTOR | 47 5% 1/4W | |
| | R1566 | QRE141J-101Y | C RESISTOR | 100 5% 1/4W | |
| | R1567 | QRE141J-101Y | C RESISTOR | 100 5% 1/4W | |
| | R1568 | NRSA63J-332X | MG RESISTOR | | |
| | R1569 | QRE141J-470Y | C RESISTOR | 47 5% 1/4W | |
| | R1570 | NRSA63J-471X | MG RESISTOR | | |
| | R1571 | NRSA63J-471X | MG RESISTOR | | |
| | R1572 | NRSA63J-752X | MG RESISTOR | | |
| | R1573 | NRSA63J-752X | MG RESISTOR | | |
| | R1574 | NRSA63J-472X | MG RESISTOR | | |
| | R1575 | NRSA63J-104X | MG RESISTOR | | |
| | R1580 | QRE141J-470Y | C RESISTOR | 47 5% 1/4W | |
| | R1581 | NRSA63J-471X | MG RESISTOR | | |
| | R1582 | NRSA63J-471X | MG RESISTOR | | |
| | R1583 | NRSA63J-471X | MG RESISTOR | | |
| | R1584 | NRSA63J-471X | MG RESISTOR | | |
| | R1586 | QRE141J-101Y | C RESISTOR | 100 5% 1/4W | |
| | R1587 | QRE141J-101Y | C RESISTOR | 100 5% 1/4W | |
| | R1588 | NRSA63J-332X | MG RESISTOR | | |
| | R1589 | QRE141J-470Y | C RESISTOR | 47 5% 1/4W | |
| | R1590 | NRSA63J-471X | MG RESISTOR | | |
| | R1591 | NRSA63J-471X | MG RESISTOR | | |
| | R1595 | QRE141J-103Y | C RESISTOR | 10K 5% 1/4W | |
| | R1666 | NRSA63J-102X | MG RESISTOR | | |
| | R1667 | NRSA63J-102X | MG RESISTOR | | |
| | R1686 | NRSA63J-102X | MG RESISTOR | | |
| | R1687 | NRSA63J-102X | MG RESISTOR | | |

| △ | Item | Parts number | Parts name | Remarks | Area |
|---|-------|--------------|------------|---------|------|
| | SP 10 | VYSA1R3-049 | SPACER | | |
| | SP 11 | VYSA1R3-049 | SPACER | | |
| | X 500 | QAX0671-001Z | RESONATOR | | |
| | X 670 | QAX0572-001Z | CRYSTAL | | |

■ Electrical parts list (Front board)

Block No. 03

| ▲ | Item | Parts number | Parts name | Remarks | Area | ▲ | Item | Parts number | Parts name | Remarks | Area |
|---|-------|----------------|----------------|----------------|------|---|-------|---------------|-----------------|---------------|------|
| | C 233 | QFLC1HJ-104Z | M CAPACITOR | .10MF 5% 50V | | | C1064 | QCBB1HK-151Y | C CAPACITOR | 150PF 10% 50V | |
| | C 801 | FQCF31HP-103Z | C CAPACITOR | | | | C1065 | QCBB1HK-151Y | C CAPACITOR | 150PF 10% 50V | |
| | C 803 | QETN0JM-477Z | E CAPACITOR | 470MF 20% 6.3V | | | C1066 | QCBB1HK-331Y | C CAPACITOR | 330PF 10% 50V | |
| | C 804 | QETN0JM-477Z | E CAPACITOR | 470MF 20% 6.3V | | | C1067 | QEKC1HM-225Z | E CAPACITOR | 2.2MF 20% 50V | |
| | C 805 | QDGB1HK-102Y | C CAPACITOR | | | | C1068 | QEKC1HM-224Z | E CAPACITOR | .22MF 20% 50V | |
| | C 808 | QCSB1HJ-150Y | C CAPACITOR | 15PF 5% 50V | | | C1070 | QDXB1CM-222Y | C CAPACITOR | | |
| | C 809 | QCSB1HJ-150Y | C CAPACITOR | 15PF 5% 50V | | | D 801 | 1N4003S-T5 | SI DIODE | | |
| | C 815 | EETC1HM-226ZJC | E CAPACITOR | | | | D 803 | 1SS119-041-T2 | SI DIODE | | |
| | C 816 | EETC1CM-476ZJC | E CAPACITOR | | | | D 804 | 1SS119-041-T2 | SI DIODE | | |
| | C 817 | EETC1HM-226ZJC | E CAPACITOR | | | | D 805 | 1SS119-041-T2 | SI DIODE | | |
| | C 820 | QCZ0202-155Z | ML C CAPACITOR | 1.5MF | | | D 807 | 1N4003S-T5 | SI DIODE | | |
| | C 821 | QDYB1CM-103Y | C CAPACITOR | | | | D 812 | 1SS119-041-T2 | SI DIODE | | |
| | C 823 | QFVJ1HJ-334Z | MF CAPACITOR | .33MF 5% 50V | | | D 831 | DZ5.1BSB-T2 | ZENER DIODE | | |
| | C 831 | QDYB1CM-103Y | C CAPACITOR | | | | D 832 | DZ5.1BSB-T2 | ZENER DIODE | | |
| | C 832 | QDYB1CM-103Y | C CAPACITOR | | | | D 903 | QLMP-KB49 | LED | | |
| | C 835 | QDGB1HK-102Y | C CAPACITOR | | | | D 904 | L-192ZSRD-T | LED | | |
| | C 836 | EETC1EM-106ZJC | E CAPACITOR | | | | D 905 | L-192ZSRD-T | LED | | |
| | C 837 | EETC1AM-107ZJC | E CAPACITOR | | | | D 906 | SLR-342VC-T | LED | | |
| | C 838 | QDGB1HK-102Y | C CAPACITOR | | | | D 907 | SLR-342VC-T | LED | | |
| | C 840 | EETC1AM-107ZJC | E CAPACITOR | | | | D 908 | SLR-342VC-T | LED | | |
| | C 857 | EETC1HM-226ZJC | E CAPACITOR | | | | D 918 | L-192ZSRD-T | LED | | |
| | C 872 | EETC1HM-224ZJC | E CAPACITOR | | | | D 919 | L-192ZSRD-T | LED | | |
| | C 873 | EETC1HM-224ZJC | E CAPACITOR | | | | D 920 | L-192ZSRD-T | LED | | |
| | C 874 | QFLC1HJ-104Z | M CAPACITOR | .10MF 5% 50V | | | D 940 | L-192ZSRD-T | LED | AUX | |
| | C 875 | QFLC1HJ-104Z | M CAPACITOR | .10MF 5% 50V | | | D 941 | L-192ZSRD-T | LED | TUNER | |
| | C 889 | EETC1HM-475ZJC | E CAPACITOR | | | | D 942 | L-192ZSRD-T | LED | TAPE | |
| | C 901 | QDYB1CM-103Y | C CAPACITOR | | | | D 943 | L-192ZSRD-T | LED | DVD | |
| | C 902 | QDYB1CM-103Y | C CAPACITOR | | | | D 944 | L-192ZSRD-T | LED | TUNER | |
| | C 935 | QDYB1CM-103Y | C CAPACITOR | | | | D 945 | L-192ZSRD-T | LED | AUX | |
| | C 956 | QDYB1CM-103Y | C CAPACITOR | | | | D 953 | L-192ZSRD-T | LED | TAPE | |
| | C 957 | QDYB1CM-103Y | C CAPACITOR | | | | D 954 | L-192ZSRD-T | LED | DVD | |
| | C 960 | QDYB1CM-103Y | C CAPACITOR | | | | D 956 | L-192ZSRD-T | LED | SOUND MODE | |
| | C 961 | QDYB1CM-103Y | C CAPACITOR | | | | D 957 | L-192ZSRD-T | LED | SOUND MODE | |
| | C 962 | QDYB1CM-103Y | C CAPACITOR | | | | D 960 | L-192ZSRD-T | LED | WOOFER | |
| | C 963 | QDYB1CM-103Y | C CAPACITOR | | | | D 961 | L-192ZSRD-T | LED | WOOFER | |
| | CN316 | QGF1210G1-09 | CONNECTOR | | | | D 962 | L-192ZSRD-T | LED | STANDBY | |
| | CN860 | QGF1205F1-17 | CONNECTOR | | | | D 964 | 1SS119-041-T2 | SI DIODE | | |
| | CN861 | QGF1205F1-14 | CONNECTOR | | | | D1003 | DZ2.4BSB-T2 | ZENER DIODE | | |
| | CN870 | QGD2503F1-11 | CONN.TERMINAL | | | | D1021 | DZ5.1BSB-T2 | ZENER DIODE | | |
| | CN881 | QGF1210G1-24 | FFC/FPC CONNE | | | | D1061 | 1SS119-041-T2 | SI DIODE | | |
| | CN920 | QGF1205F1-24 | CONNECTOR | | | | D1062 | DZ2.4BSB-T2 | ZENER DIODE | | |
| | C1004 | QDGB1HK-102Y | C CAPACITOR | | | | FL801 | QLF0081-001 | FL DISPLAY TUBE | | |
| | C1005 | QDGB1HK-102Y | C CAPACITOR | | | | FW230 | QUM153-11DGZ4 | PARA RIBON WIRE | | |
| | C1006 | QDGB1HK-102Y | C CAPACITOR | | | | FW713 | QUM023-33DGZ4 | FLAT WIRE | | |
| | C1021 | QDGB1HK-102Y | C CAPACITOR | | | | FW901 | QUM02B-13DGZ4 | PARA RIBON WIRE | | |
| | C1022 | QDGB1HK-102Y | C CAPACITOR | | | | FW915 | QUM027-18Z4Z4 | PARA RIBON WIRE | | |
| | C1023 | QDGB1HK-102Y | C CAPACITOR | | | ▲ | IC810 | MN101C35DEP | IC | | |
| | C1034 | QFLC1HJ-104Z | M CAPACITOR | .10MF 5% 50V | | | IC811 | BU2092 | IC | | |
| | C1035 | EETC1AM-107ZJC | E CAPACITOR | | | | IC812 | BA3835S | IC | | |
| | C1036 | QCBB1HK-101Y | C CAPACITOR | 100PF 10% 50V | | | IC830 | KIA7042AP-T | IC | | |
| | C1037 | QDYB1CM-103Y | C CAPACITOR | | | | IC901 | NJM4580L | IC | | |
| | C1038 | QDXB1CM-472Y | C CAPACITOR | | | | IC902 | BU9253AS | IC | | |
| | C1039 | QDYB1CM-103Y | C CAPACITOR | | | | IC951 | GP1U271X | IC | | |
| | C1040 | QDXB1CM-332Y | C CAPACITOR | | | | JS901 | QSW0911-001 | ROTARY SWITCH | | |
| | C1041 | QDYB1CM-103Y | C CAPACITOR | | | | JS956 | QSW0912-001 | ROTARY SWITCH | S/WOOFER VOL | |
| | C1042 | EETC1EM-226ZJC | E CAPACITOR | | | | JS960 | QSW0911-001 | ROTARY SWITCH | S/MODE VOL | |
| | C1043 | QFVJ1HJ-474Z | MF CAPACITOR | .47MF 5% 50V | | | JS962 | QSW0987-001 | ROTARY ENCODER | MAIN VOL | |
| | C1044 | QDYB1CM-103Y | C CAPACITOR | | | | J1001 | QNS0183-001 | HEADPHONE JACK | HEAD PHONE | |
| | C1045 | EETC1HM-225ZJC | E CAPACITOR | | | | J1021 | QNS0184-001 | JACK | | |
| | C1046 | EETC1HM-105ZJC | E CAPACITOR | | | | J1022 | QNS0184-001 | JACK | | |
| | C1061 | QEKC1AM-227Z | E CAPACITOR | 220MF 20% 10V | | | L 801 | QQL244K-100Z | INDUCTOR | | |
| | C1062 | EEKC1AM-107ZJC | E CAPACITOR | | | | L 802 | QQL231K-220Y | INDUCTOR | | |
| | C1063 | EEKC1HM-475ZJC | E CAPACITOR | | | | L 803 | QQL244K-100Z | INDUCTOR | | |

■ Electrical parts list (Front board)

Block No. 03

| △ | Item | Parts number | Parts name | Remarks | Area | △ | Item | Parts number | Parts name | Remarks | Area |
|---|-------|----------------|--------------|--------------|------|---|-------|--------------|------------|--------------|-------|
| | L 805 | QQL244K-100Z | INDUCTOR | | | | R 845 | QRE141J-102Y | C RESISTOR | 1.0K 5% 1/4W | |
| | L 806 | QQL244K-100Z | INDUCTOR | | | | R 846 | QRE141J-102Y | C RESISTOR | 1.0K 5% 1/4W | |
| | L 813 | QQR1277-001Z | F.BEADS | | | | R 847 | QRE141J-102Y | C RESISTOR | 1.0K 5% 1/4W | |
| | L1003 | QQL231K-2R2Y | INDUCTOR | | | | R 848 | QRE141J-331Y | C RESISTOR | 330 5% 1/4W | |
| | Q 809 | 2SD1991A/RS/-T | TRANSISTOR | | | | R 849 | QRE141J-102Y | C RESISTOR | 1.0K 5% 1/4W | |
| | Q 810 | 2SD1991A/RS/-T | TRANSISTOR | | | | R 850 | QRE141J-102Y | C RESISTOR | 1.0K 5% 1/4W | |
| | Q 811 | 2SD1991A/RS/-T | TRANSISTOR | | | | R 851 | QRE141J-102Y | C RESISTOR | 1.0K 5% 1/4W | |
| | Q 812 | 2SD1991A/RS/-T | TRANSISTOR | | | | R 852 | QRE141J-102Y | C RESISTOR | 1.0K 5% 1/4W | |
| | Q 813 | 2SD1991A/RS/-T | TRANSISTOR | | | | R 854 | QRE141J-102Y | C RESISTOR | 1.0K 5% 1/4W | |
| | Q 816 | 2SD1991A/RS/-T | TRANSISTOR | | | | R 855 | QRE141J-102Y | C RESISTOR | 1.0K 5% 1/4W | |
| | Q 817 | 2SD1991A/RS/-T | TRANSISTOR | | | | R 856 | QRE141J-104Y | C RESISTOR | 100K 5% 1/4W | |
| | Q 858 | 2SD1991A/RS/-T | TRANSISTOR | | | | R 857 | QRE141J-104Y | C RESISTOR | 100K 5% 1/4W | |
| | Q 875 | KRC102M-T | D.TRANSISTOR | | | | R 858 | QRE141J-104Y | C RESISTOR | 100K 5% 1/4W | |
| | Q 879 | 2SD1991A/RS/-T | TRANSISTOR | | | | R 859 | QRE141J-104Y | C RESISTOR | 100K 5% 1/4W | |
| | Q 890 | 2SD1991A/RS/-T | TRANSISTOR | | | | R 865 | QRE141J-104Y | C RESISTOR | 100K 5% 1/4W | |
| | Q 905 | KRC104M-T | D.TRANSISTOR | | | | R 866 | QRE141J-104Y | C RESISTOR | 100K 5% 1/4W | |
| | Q 906 | KRC104M-T | D.TRANSISTOR | | | | R 867 | QRE141J-104Y | C RESISTOR | 100K 5% 1/4W | |
| | Q 918 | KRC102M-T | D.TRANSISTOR | | | | R 868 | QRE141J-104Y | C RESISTOR | 100K 5% 1/4W | |
| | Q 919 | KRC102M-T | D.TRANSISTOR | | | | R 869 | QRE141J-104Y | C RESISTOR | 100K 5% 1/4W | |
| | Q 920 | KRC102M-T | D.TRANSISTOR | | | | R 870 | QRE141J-104Y | C RESISTOR | 100K 5% 1/4W | |
| | Q 961 | KRA102M-T | D.TRANSISTOR | | | | R 871 | QRE141J-104Y | C RESISTOR | 100K 5% 1/4W | |
| | Q1021 | KRA111M-T | D.TRANSISTOR | | | | R 872 | QRE141J-104Y | C RESISTOR | 100K 5% 1/4W | |
| | Q1022 | KRA111M-T | D.TRANSISTOR | | | | R 873 | QRE141J-104Y | C RESISTOR | 100K 5% 1/4W | |
| | Q1023 | KRA111M-T | D.TRANSISTOR | | | | R 874 | QRE141J-104Y | C RESISTOR | 100K 5% 1/4W | |
| | Q1061 | 2SC3576-JVC-T | TRANSISTOR | | | | R 876 | QRE141J-103Y | C RESISTOR | 10K 5% 1/4W | |
| | R 151 | QRE141J-221Y | C RESISTOR | 220 5% 1/4W | | | R 877 | QRE141J-103Y | C RESISTOR | 10K 5% 1/4W | |
| | R 233 | QRK126J-470X | C RESISTOR | 47 5% 1/2W | | | R 878 | QRE141J-104Y | C RESISTOR | 100K 5% 1/4W | |
| | R 234 | QRK126J-470X | C RESISTOR | 47 5% 1/2W | | | R 879 | QRE141J-104Y | C RESISTOR | 100K 5% 1/4W | |
| | R 801 | QRE141J-331Y | C RESISTOR | 330 5% 1/4W | | | R 880 | QRE141J-104Y | C RESISTOR | 100K 5% 1/4W | |
| | R 807 | QRE141J-103Y | C RESISTOR | 10K 5% 1/4W | | | R 881 | QRE141J-103Y | C RESISTOR | 10K 5% 1/4W | |
| | R 808 | QRE141J-103Y | C RESISTOR | 10K 5% 1/4W | | | R 882 | QRE141J-103Y | C RESISTOR | 10K 5% 1/4W | |
| | R 810 | QRE141J-103Y | C RESISTOR | 10K 5% 1/4W | | | R 883 | QRE141J-103Y | C RESISTOR | 10K 5% 1/4W | |
| | R 811 | QRE141J-103Y | C RESISTOR | 10K 5% 1/4W | | | R 884 | QRE141J-102Y | C RESISTOR | 1.0K 5% 1/4W | |
| | R 812 | QRE141J-103Y | C RESISTOR | 10K 5% 1/4W | | | R 885 | QRE141J-221Y | C RESISTOR | 220 5% 1/4W | |
| | R 813 | QRE141J-103Y | C RESISTOR | 10K 5% 1/4W | | | R 886 | QRE141J-221Y | C RESISTOR | 220 5% 1/4W | |
| | R 814 | QRE141J-562Y | C RESISTOR | 5.6K 5% 1/4W | | | R 887 | QRE141J-221Y | C RESISTOR | 220 5% 1/4W | |
| | R 815 | QRE141J-563Y | C RESISTOR | 56K 5% 1/4W | | | R 888 | QRE141J-221Y | C RESISTOR | 220 5% 1/4W | |
| | R 816 | QRE141J-563Y | C RESISTOR | 56K 5% 1/4W | | | R 889 | QRE141J-221Y | C RESISTOR | 220 5% 1/4W | |
| | R 817 | QRE141J-103Y | C RESISTOR | 10K 5% 1/4W | | | R 890 | QRE141J-104Y | C RESISTOR | 100K 5% 1/4W | |
| | R 818 | QRE141J-103Y | C RESISTOR | 10K 5% 1/4W | | | R 891 | QRE141J-104Y | C RESISTOR | 100K 5% 1/4W | |
| | R 819 | QRE141J-102Y | C RESISTOR | 1.0K 5% 1/4W | | | R 893 | QRE141J-102Y | C RESISTOR | 1.0K 5% 1/4W | |
| | R 820 | QRE141J-102Y | C RESISTOR | 1.0K 5% 1/4W | | | R 894 | QRE141J-183Y | C RESISTOR | 18K 5% 1/4W | UX |
| | R 821 | QRE141J-103Y | C RESISTOR | 10K 5% 1/4W | | | R 894 | QRE141J-334Y | C RESISTOR | 330K 5% 1/4W | US,UN |
| | R 822 | QRE141J-103Y | C RESISTOR | 10K 5% 1/4W | | | R 895 | QRE141J-102Y | C RESISTOR | 1.0K 5% 1/4W | |
| | R 823 | QRE141J-102Y | C RESISTOR | 1.0K 5% 1/4W | | | R 896 | QRE141J-103Y | C RESISTOR | 10K 5% 1/4W | |
| | R 824 | QRE141J-102Y | C RESISTOR | 1.0K 5% 1/4W | | | R 897 | QRE141J-753Y | C RESISTOR | 75K 5% 1/4W | |
| | R 825 | QRE141J-104Y | C RESISTOR | 100K 5% 1/4W | | | R 901 | QRE141J-331Y | C RESISTOR | 330 5% 1/4W | |
| | R 826 | QRE141J-104Y | C RESISTOR | 100K 5% 1/4W | | | R 902 | QRE141J-103Y | C RESISTOR | 10K 5% 1/4W | |
| | R 827 | QRE141J-103Y | C RESISTOR | 10K 5% 1/4W | | | R 903 | QRE141J-101Y | C RESISTOR | 100 5% 1/4W | |
| | R 828 | QRE141J-103Y | C RESISTOR | 10K 5% 1/4W | | | R 904 | QRE141J-331Y | C RESISTOR | 330 5% 1/4W | |
| | R 829 | QRE141J-103Y | C RESISTOR | 10K 5% 1/4W | | | R 905 | QRE141J-104Y | C RESISTOR | 100K 5% 1/4W | |
| | R 831 | QRE141J-104Y | C RESISTOR | 100K 5% 1/4W | | | R 906 | QRE141J-104Y | C RESISTOR | 100K 5% 1/4W | |
| | R 832 | QRE141J-104Y | C RESISTOR | 100K 5% 1/4W | | | R 907 | QRE141J-201Y | C RESISTOR | 200 5% 1/4W | |
| | R 833 | QRE141J-104Y | C RESISTOR | 100K 5% 1/4W | | | R 908 | QRE141J-562Y | C RESISTOR | 5.6K 5% 1/4W | |
| | R 834 | QRE141J-104Y | C RESISTOR | 100K 5% 1/4W | | | R 909 | QRE141J-201Y | C RESISTOR | 200 5% 1/4W | |
| | R 835 | QRE141J-104Y | C RESISTOR | 100K 5% 1/4W | | | R 910 | QRE141J-201Y | C RESISTOR | 200 5% 1/4W | |
| | R 836 | QRE141J-104Y | C RESISTOR | 100K 5% 1/4W | | | R 916 | QRE141J-102Y | C RESISTOR | 1.0K 5% 1/4W | |
| | R 837 | QRE141J-104Y | C RESISTOR | 100K 5% 1/4W | | | R 917 | QRE141J-102Y | C RESISTOR | 1.0K 5% 1/4W | |
| | R 838 | QRE141J-102Y | C RESISTOR | 1.0K 5% 1/4W | | | R 918 | QRE141J-201Y | C RESISTOR | 200 5% 1/4W | |
| | R 839 | QRE141J-102Y | C RESISTOR | 1.0K 5% 1/4W | | | R 919 | QRE141J-201Y | C RESISTOR | 200 5% 1/4W | |
| | R 840 | QRE141J-103Y | C RESISTOR | 10K 5% 1/4W | | | R 920 | QRE141J-201Y | C RESISTOR | 200 5% 1/4W | |
| | R 841 | QRE141J-103Y | C RESISTOR | 10K 5% 1/4W | | | R 921 | QRE141J-334Y | C RESISTOR | 330K 5% 1/4W | |
| | R 842 | QRE141J-103Y | C RESISTOR | 10K 5% 1/4W | | | R 930 | QRE141J-103Y | C RESISTOR | 10K 5% 1/4W | |

■ Electrical parts list (Front board)

Block No. 03

| △ | Item | Parts number | Parts name | Remarks | Area | △ | Item | Parts number | Parts name | Remarks | Area |
|---|-------|--------------|--------------|--------------|------|-------|-------|---------------|----------------|--------------|------|
| | R 931 | QRE141J-222Y | C RESISTOR | 2.2K 5% 1/4W | | | R1062 | QRE141J-123Y | C RESISTOR | 12K 5% 1/4W | |
| | R 932 | QRE141J-272Y | C RESISTOR | 2.7K 5% 1/4W | | | R1063 | QRE141J-391Y | C RESISTOR | 390 5% 1/4W | |
| | R 933 | QRE141J-392Y | C RESISTOR | 3.9K 5% 1/4W | | | R1064 | QRE141J-152Y | C RESISTOR | 1.5K 5% 1/4W | |
| | R 935 | QRE141J-562Y | C RESISTOR | 5.6K 5% 1/4W | | | R1065 | QRE141J-101Y | C RESISTOR | 100 5% 1/4W | |
| | R 936 | QRE141J-122Y | C RESISTOR | 1.2K 5% 1/4W | | | R1066 | QRE141J-475Y | C RESISTOR | 4.7M 5% 1/4W | |
| | R 937 | QRE141J-152Y | C RESISTOR | 1.5K 5% 1/4W | | | R1067 | QRE141J-151Y | C RESISTOR | 150 5% 1/4W | |
| | R 938 | QRE141J-222Y | C RESISTOR | 2.2K 5% 1/4W | | | R1068 | QRE141J-203Y | C RESISTOR | 20K 5% 1/4W | |
| | R 939 | QRE141J-272Y | C RESISTOR | 2.7K 5% 1/4W | | | R1069 | QRE141J-102Y | C RESISTOR | 1.0K 5% 1/4W | |
| | R 940 | QRE141J-680Y | C RESISTOR | 68 5% 1/4W | | | R1070 | QRE141J-561Y | C RESISTOR | 560 5% 1/4W | |
| | R 941 | QRE141J-680Y | C RESISTOR | 68 5% 1/4W | | | R1071 | QRE141J-472Y | C RESISTOR | 4.7K 5% 1/4W | |
| | R 942 | QRE141J-392Y | C RESISTOR | 3.9K 5% 1/4W | | | S 901 | QSW0825-001Z | TACT SWITCH | | |
| | R 943 | QRE141J-103Y | C RESISTOR | 10K 5% 1/4W | | | S 902 | QSW0825-001Z | TACT SWITCH | | |
| | R 944 | QRE141J-562Y | C RESISTOR | 5.6K 5% 1/4W | | | S 915 | QSW0825-001Z | TACT SWITCH | | |
| | R 945 | QRE141J-392Y | C RESISTOR | 3.9K 5% 1/4W | | | S 916 | QSW0825-001Z | TACT SWITCH | | |
| | R 946 | QRE141J-272Y | C RESISTOR | 2.7K 5% 1/4W | | | S 917 | QSW0825-001Z | TACT SWITCH | | |
| | R 947 | QRE141J-222Y | C RESISTOR | 2.2K 5% 1/4W | | | S 931 | QSW0825-001Z | TACT SWITCH | | |
| | R 948 | QRE141J-152Y | C RESISTOR | 1.5K 5% 1/4W | | | S 932 | QSW0825-001Z | TACT SWITCH | | |
| | R 949 | QRE141J-122Y | C RESISTOR | 1.2K 5% 1/4W | | | S 933 | QSW0825-001Z | TACT SWITCH | | |
| | R 950 | QRE141J-102Y | C RESISTOR | 1.0K 5% 1/4W | | | S 935 | QSW0825-001Z | TACT SWITCH | | |
| | R 952 | QRE141J-122Y | C RESISTOR | 1.2K 5% 1/4W | | | S 936 | QSW0825-001Z | TACT SWITCH | | |
| | R 953 | QRE141J-680Y | C RESISTOR | 68 5% 1/4W | | | S 937 | QSW0825-001Z | TACT SWITCH | | |
| | R 954 | QRE141J-680Y | C RESISTOR | 68 5% 1/4W | | | S 938 | QSW0825-001Z | TACT SWITCH | | |
| | R 955 | QRE141J-152Y | C RESISTOR | 1.5K 5% 1/4W | | | S 939 | QSW0825-001Z | TACT SWITCH | | |
| | R 956 | QRE141J-331Y | C RESISTOR | 330 5% 1/4W | | | S 942 | QSW0825-001Z | TACT SWITCH | | |
| | R 957 | QRE141J-331Y | C RESISTOR | 330 5% 1/4W | | | S 943 | QSW0825-001Z | TACT SWITCH | | |
| | R 959 | QRE141J-331Y | C RESISTOR | 330 5% 1/4W | | | S 944 | QSW0825-001Z | TACT SWITCH | | |
| | R 960 | QRE141J-331Y | C RESISTOR | 330 5% 1/4W | | | S 945 | QSW0825-001Z | TACT SWITCH | | |
| | R 961 | QRE141J-101Y | C RESISTOR | 100 5% 1/4W | | | S 946 | QSW0825-001Z | TACT SWITCH | | |
| | R 962 | QRE141J-103Y | C RESISTOR | 10K 5% 1/4W | | | S 947 | QSW0825-001Z | TACT SWITCH | | |
| | R 963 | QRE141J-562Y | C RESISTOR | 5.6K 5% 1/4W | | | S 948 | QSW0825-001Z | TACT SWITCH | | |
| | R 964 | QRE141J-392Y | C RESISTOR | 3.9K 5% 1/4W | | | S 949 | QSW0825-001Z | TACT SWITCH | | |
| | R 965 | QRE141J-103Y | C RESISTOR | 10K 5% 1/4W | | | S 950 | QSW0825-001Z | TACT SWITCH | | |
| | R 969 | QRE141J-680Y | C RESISTOR | 68 5% 1/4W | | | S 951 | QSW0825-001Z | TACT SWITCH | | |
| | R 970 | QRE141J-101Y | C RESISTOR | 100 5% 1/4W | | | S 952 | QSW0825-001Z | TACT SWITCH | | |
| | R 991 | QRE141J-202Y | C RESISTOR | 2.0K 5% 1/4W | | | S 963 | QSW0825-001Z | TACT SWITCH | | |
| | R 992 | QRE141J-202Y | C RESISTOR | 2.0K 5% 1/4W | | | S 995 | QSW0825-001Z | TACT SWITCH | | |
| | R 993 | QRE141J-122Y | C RESISTOR | 1.2K 5% 1/4W | | | S 996 | QSW0825-001Z | TACT SWITCH | | |
| | R 994 | QRE141J-753Y | C RESISTOR | 75K 5% 1/4W | | US,UN | S 997 | QSW0825-001Z | TACT SWITCH | | |
| | R 994 | QRE141J-183Y | C RESISTOR | 18K 5% 1/4W | | UX | S 998 | QSW0825-001Z | TACT SWITCH | | |
| | R 995 | QRE141J-222Y | C RESISTOR | 2.2K 5% 1/4W | | | S 999 | QSW0825-001Z | TACT SWITCH | | |
| | R 996 | QRE141J-272Y | C RESISTOR | 2.7K 5% 1/4W | | | SP801 | VYH7653-001 | IC HOLDER | | |
| | R 997 | QRE141J-152Y | C RESISTOR | 1.5K 5% 1/4W | | | TW800 | QUB220-15DMHP | SIN TWIST WIRE | | |
| | R 998 | QRE141J-102Y | C RESISTOR | 1.0K 5% 1/4W | | | TW801 | QUB220-15DMHP | SIN TWIST WIRE | GND WIRE | |
| | RA801 | QRB169J-104 | NET RESISTOR | 100K 5% 1/6W | | | VR901 | QVQ0299-B54 | V.RESISTOR | | |
| | RA802 | QRB169J-104 | NET RESISTOR | 100K 5% 1/6W | | | X 801 | QAX0718-001Z | CRYSTAL | | |
| | R1021 | QRE141J-472Y | C RESISTOR | 4.7K 5% 1/4W | | | | | | | |
| | R1022 | QRE141J-472Y | C RESISTOR | 4.7K 5% 1/4W | | | | | | | |
| | R1031 | QRE141J-203Y | C RESISTOR | 20K 5% 1/4W | | | | | | | |
| | R1032 | QRE141J-203Y | C RESISTOR | 20K 5% 1/4W | | | | | | | |
| | R1033 | QRE141J-822Y | C RESISTOR | 8.2K 5% 1/4W | | | | | | | |
| | R1034 | QRE141J-103Y | C RESISTOR | 10K 5% 1/4W | | | | | | | |
| | R1035 | QRE141J-333Y | C RESISTOR | 33K 5% 1/4W | | | | | | | |
| | R1036 | QRE141J-392Y | C RESISTOR | 3.9K 5% 1/4W | | | | | | | |
| | R1037 | QRE141J-153Y | C RESISTOR | 15K 5% 1/4W | | | | | | | |
| | R1038 | QRE141J-472Y | C RESISTOR | 4.7K 5% 1/4W | | | | | | | |
| | R1039 | QRE141J-103Y | C RESISTOR | 10K 5% 1/4W | | | | | | | |
| | R1040 | QRE141J-272Y | C RESISTOR | 2.7K 5% 1/4W | | | | | | | |
| | R1041 | QRE141J-203Y | C RESISTOR | 20K 5% 1/4W | | | | | | | |
| | R1042 | QRE141J-221Y | C RESISTOR | 220 5% 1/4W | | | | | | | |
| | R1043 | QRE141J-203Y | C RESISTOR | 20K 5% 1/4W | | | | | | | |
| | R1044 | QRE141J-562Y | C RESISTOR | 5.6K 5% 1/4W | | | | | | | |
| | R1045 | QRE141J-102Y | C RESISTOR | 1.0K 5% 1/4W | | | | | | | |
| | R1061 | QRE141J-103Y | C RESISTOR | 10K 5% 1/4W | | | | | | | |

Electrical parts list (Power supply board) Block No. 04

| △ | Item | Parts number | Parts name | Remarks | Area |
|---|-------|----------------|-----------------|--------------|------|
| △ | C 254 | QFZ9075-683 | M CAPACITOR | .068MF | |
| | C 381 | QDGB1HK-102Y | C CAPACITOR | | |
| | C 382 | QDGB1HK-102Y | C CAPACITOR | | |
| | C 383 | QDGB1HK-102Y | C CAPACITOR | | |
| | C 384 | QDGB1HK-102Y | C CAPACITOR | | |
| | C 387 | EETC0JM-107ZJC | E CAPACITOR | | |
| | C 388 | QDGB1HK-102Y | C CAPACITOR | | |
| | CN208 | WJK0114-002A | E-SI C WIRE C-B | | |
| | CN209 | WJK0071-003A | E-SI C WIRE C-B | | |
| | CN213 | QGB2510K2-04 | CONNECTOR | | |
| | CN214 | QJK015-071214 | CONN.WIRE ASSY | | |
| | CN218 | QGA7901F1-03 | CONNECTOR | | |
| | CN219 | QGA7901C1-04 | CONNECTOR | | |
| | CN220 | QGD2504C1-03Z | SOCKET | | |
| | CN250 | QGA7901C1-02 | CONNECTOR | | |
| | CN371 | QGB1214K1-14S | CONNECTOR | | |
| | CN372 | QGB2510J1-06 | CONNECTOR | | |
| | CN373 | QGB2510J1-15 | CONNECTOR | | |
| | D 390 | 1SS133-T2 | SI DIODE | | |
| | D 391 | 1SS133-T2 | SI DIODE | | |
| | EP250 | E409182-001SM | GRAND TERMINAL | | |
| △ | FT111 | QNG0020-001Z | FUSE CLIP | | |
| △ | FT112 | QNG0020-001Z | FUSE CLIP | | |
| △ | FT131 | QNG0020-001Z | FUSE CLIP | | |
| △ | FT132 | QNG0020-001Z | FUSE CLIP | | |
| △ | FT511 | QNG0020-001Z | FUSE CLIP | | |
| △ | FT512 | QNG0020-001Z | FUSE CLIP | | |
| △ | FT521 | QNG0020-001Z | FUSE CLIP | | |
| △ | FT522 | QNG0020-001Z | FUSE CLIP | | |
| △ | FT531 | QNG0020-001Z | FUSE CLIP | | |
| △ | FT532 | QNG0020-001Z | FUSE CLIP | | |
| | J 371 | GP1FA550TZ | OPT TRANSMITTER | | |
| | J 372 | QNN0436-002 | PIN JACK | | |
| | R 387 | QRE141J-2R2Y | C RESISTOR | 2.2 5% 1/4W | |
| | R 388 | QRE141J-104Y | C RESISTOR | 100K 5% 1/4W | |
| | R 390 | QRE141J-221Y | C RESISTOR | 220 5% 1/4W | |
| | R 394 | QRK126J-121X | C RESISTOR | 120 5% 1/2W | |
| | RY370 | QSK0109-001 | RELAY | | |
| | RY371 | QSK0109-001 | RELAY | | |
| △ | R1002 | ERX12SJR33E | UNF.C.RESISTOR | | |
| △ | S 500 | QSW0812-001 | VOLTAGE SWITCH | | |

■ Electrical parts list (DVD servo board)

Block No. 05

| ▲ | Item | Parts number | Parts name | Remarks | Area | ▲ | Item | Parts number | Parts name | Remarks | Area |
|---|-------|--------------|-----------------|---------|------|---|-------|--------------|-------------|---------|------|
| | C 1 | NCB31CK-104X | C CAPACITOR | | | | C 228 | NCB31HK-102X | C CAPACITOR | | |
| | C 2 | NEA70JM-226X | E CAPACITOR | | | | C 237 | NCB31CK-104X | C CAPACITOR | | |
| | C 3 | NEA70JM-226X | E CAPACITOR | | | | C 238 | NCB31CK-104X | C CAPACITOR | | |
| | C 4 | NCB31CK-104X | C CAPACITOR | | | | C 239 | NCB31CK-183X | C CAPACITOR | | |
| | C 5 | NEA70JM-226X | E CAPACITOR | | | | C 240 | NCS31HJ-101X | C CAPACITOR | | |
| | C 6 | NCB31CK-104X | C CAPACITOR | | | | C 241 | NCB31CK-103X | C CAPACITOR | | |
| | C 11 | NEA70JM-107X | E CAPACITOR | | | | C 242 | NCB11CK-105X | C CAPACITOR | | |
| | C 12 | NCB31CK-104X | C CAPACITOR | | | | C 244 | NCB31CK-104X | C CAPACITOR | | |
| | C 15 | NCB31CK-104X | C CAPACITOR | | | | C 245 | NCB31CK-103X | C CAPACITOR | | |
| | C 16 | NBE20JM-106X | TS E CAP SVB20J | | | | C 246 | NCB31CK-104X | C CAPACITOR | | |
| | C 17 | NCB31CK-104X | C CAPACITOR | | | | C 247 | NCB31CK-104X | C CAPACITOR | | |
| | C 101 | NCB31HK-561X | C CAPACITOR | | | | C 248 | NCB21CK-154X | C CAPACITOR | | |
| | C 102 | NCB31CK-104X | C CAPACITOR | | | | C 249 | NCB31CK-104X | C CAPACITOR | | |
| | C 103 | NCB31CK-104X | C CAPACITOR | | | | C 250 | NCB31CK-104X | C CAPACITOR | | |
| | C 104 | NCB31CK-104X | C CAPACITOR | | | | C 251 | NCB31CK-104X | C CAPACITOR | | |
| | C 105 | NCB31CK-104X | C CAPACITOR | | | | C 253 | NCB31CK-104X | C CAPACITOR | | |
| | C 109 | NEA70JM-476X | E CAPACITOR | | | | C 254 | NEA70GM-336X | E CAPACITOR | | |
| | C 112 | NEA70JM-476X | E CAPACITOR | | | | C 255 | NCB31CK-104X | C CAPACITOR | | |
| | C 118 | NCB21CK-154X | C CAPACITOR | | | | C 256 | NEA70GM-107X | E CAPACITOR | | |
| | C 119 | NCS31HJ-221X | C CAPACITOR | | | | C 257 | NCB11CK-105X | C CAPACITOR | | |
| | C 120 | NCS31HJ-820X | C CAPACITOR | | | | C 258 | NEA70GM-107X | E CAPACITOR | | |
| | C 121 | NCS31HJ-220X | C CAPACITOR | | | | C 259 | NCB11CK-105X | C CAPACITOR | | |
| | C 122 | NCB31HK-271X | C CAPACITOR | | | | C 260 | NCB31HK-561X | C CAPACITOR | | |
| | C 123 | NCB31CK-104X | C CAPACITOR | | | | C 261 | NCB31CK-104X | C CAPACITOR | | |
| | C 124 | NCB31CK-104X | C CAPACITOR | | | | C 262 | NCB31CK-104X | C CAPACITOR | | |
| | C 125 | NCB31CK-104X | C CAPACITOR | | | | C 263 | NCB31CK-104X | C CAPACITOR | | |
| | C 126 | NEX40JM-566X | E CAPACITOR | | | | C 264 | NCB21CK-474X | C CAPACITOR | | |
| | C 127 | NCB31HK-102X | C CAPACITOR | | | | C 271 | NCB31EK-332X | C CAPACITOR | | |
| | C 128 | NCB31CK-104X | C CAPACITOR | | | | C 272 | NCB31HK-331X | C CAPACITOR | | |
| | C 130 | NCB31CK-104X | C CAPACITOR | | | | C 276 | NCB31CK-104X | C CAPACITOR | | |
| | C 131 | NCS31HJ-120X | C CAPACITOR | | | | C 277 | NCB31CK-104X | C CAPACITOR | | |
| | C 132 | NCB31CK-104X | C CAPACITOR | | | | C 278 | NCB31HK-102X | C CAPACITOR | | |
| | C 133 | NCB31HK-561X | C CAPACITOR | | | | C 279 | NCB31HK-152X | C CAPACITOR | | |
| | C 134 | NCB31HK-561X | C CAPACITOR | | | | C 281 | NCB31CK-103X | C CAPACITOR | | |
| | C 135 | NCB31CK-273X | C CAPACITOR | | | | C 283 | NCB31CK-223X | C CAPACITOR | | |
| | C 136 | NCB31CK-473X | C CAPACITOR | | | | C 284 | NCB31CK-473X | C CAPACITOR | | |
| | C 138 | NCB31CK-104X | C CAPACITOR | | | | C 288 | NCB31CK-223X | C CAPACITOR | | |
| | C 139 | NCB31CK-104X | C CAPACITOR | | | | C 289 | NCB31CK-104X | C CAPACITOR | | |
| | C 140 | NEA70JM-226X | E CAPACITOR | | | | C 291 | NCB31CK-104X | C CAPACITOR | | |
| | C 141 | NCB31CK-104X | C CAPACITOR | | | | C 292 | NEA70JM-226X | E CAPACITOR | | |
| | C 143 | NCB31CK-104X | C CAPACITOR | | | | C 293 | NEA71CM-226X | E CAPACITOR | | |
| | C 144 | NCB31CK-104X | C CAPACITOR | | | | C 301 | NCB31CK-104X | C CAPACITOR | | |
| | C 145 | NCB31CK-103X | C CAPACITOR | | | | C 302 | NCB31CK-104X | C CAPACITOR | | |
| | C 151 | NEA70JM-226X | E CAPACITOR | | | | C 303 | NCB31CK-104X | C CAPACITOR | | |
| | C 152 | NEX40JM-156X | E CAPACITOR | | | | C 304 | NCB31CK-104X | C CAPACITOR | | |
| | C 153 | NCB31CK-104X | C CAPACITOR | | | | C 305 | NCB31CK-104X | C CAPACITOR | | |
| | C 159 | NCB31CK-104X | C CAPACITOR | | | | C 306 | NCB31CK-104X | C CAPACITOR | | |
| | C 160 | NCB31CK-104X | C CAPACITOR | | | | C 307 | NCB31CK-104X | C CAPACITOR | | |
| | C 161 | NEA70GM-336X | E CAPACITOR | | | | C 309 | NCB31CK-104X | C CAPACITOR | | |
| | C 202 | NCB31HK-561X | C CAPACITOR | | | | C 310 | NCB31CK-104X | C CAPACITOR | | |
| | C 203 | NCB31HK-561X | C CAPACITOR | | | | C 311 | NCB31CK-104X | C CAPACITOR | | |
| | C 204 | NCB31HK-331X | C CAPACITOR | | | | C 312 | NCS31HJ-180X | C CAPACITOR | | |
| | C 205 | NCS31HJ-121X | C CAPACITOR | | | | C 313 | NCS31HJ-180X | C CAPACITOR | | |
| | C 206 | NCS31HJ-271X | C CAPACITOR | | | | C 314 | NCB31CK-104X | C CAPACITOR | | |
| | C 207 | NCB31HK-471X | C CAPACITOR | | | | C 315 | NCB31CK-104X | C CAPACITOR | | |
| | C 208 | NCB31CK-104X | C CAPACITOR | | | | C 316 | NEA70GM-107X | E CAPACITOR | | |
| | C 209 | NCB31HK-102X | C CAPACITOR | | | | C 317 | NCB11CK-105X | C CAPACITOR | | |
| | C 210 | NCB31HK-102X | C CAPACITOR | | | | C 318 | NCB31CK-104X | C CAPACITOR | | |
| | C 222 | NCB31CK-103X | C CAPACITOR | | | | C 319 | NCB31CK-104X | C CAPACITOR | | |
| | C 223 | NCB31HK-102X | C CAPACITOR | | | | C 320 | NCB31CK-104X | C CAPACITOR | | |
| | C 224 | NCB31CK-104X | C CAPACITOR | | | | C 321 | NCB31CK-104X | C CAPACITOR | | |
| | C 225 | NBE91CM-105X | E CAPACITOR | | | | C 324 | NCB31CK-104X | C CAPACITOR | | |
| | C 227 | NCB31HK-102X | C CAPACITOR | | | | C 326 | NCB31CK-104X | C CAPACITOR | | |

■ Electrical parts list (DVD servo board)

Block No. 05

| △ | Item | Parts number | Parts name | Remarks | Area | △ | Item | Parts number | Parts name | Remarks | Area |
|---|-------|--------------|-------------|---------|------|---|-------|-----------------|----------------|---------|------|
| | C 327 | NEA70GM-107X | E CAPACITOR | | | | C 548 | NCB31CK-104X | C CAPACITOR | | |
| | C 341 | NCB31CK-104X | C CAPACITOR | | | | C 556 | NEA70JM-107X | E CAPACITOR | | |
| | C 342 | NCB31CK-104X | C CAPACITOR | | | | C 557 | NCB31CK-104X | C CAPACITOR | | |
| | C 343 | NCB31CK-104X | C CAPACITOR | | | | C 561 | NCB31CK-104X | C CAPACITOR | | |
| | C 344 | NCB31CK-104X | C CAPACITOR | | | | C 562 | NEA70JM-226X | E CAPACITOR | | |
| | C 345 | NEA70JM-107X | E CAPACITOR | | | | C 566 | NCB31CK-104X | C CAPACITOR | | |
| | C 346 | NCB11CK-105X | C CAPACITOR | | | | C 567 | NEA70JM-226X | E CAPACITOR | | |
| | C 401 | NCB31CK-104X | C CAPACITOR | | | | CN101 | QGF0501F3-40X | FFC/FPC CONNE | PU | |
| | C 402 | NCB31CK-104X | C CAPACITOR | | | | CN501 | QGA2001F2-09X | CONNECTOR | POWER | |
| | C 405 | NCB31CK-104X | C CAPACITOR | | | | CN502 | QGF1016F2-17W | CONNECTOR | SYSTEM | |
| | C 406 | NCB31CK-104X | C CAPACITOR | | | | CN503 | QGF1016F2-09W | CONNECTOR | VIDEO | |
| | C 407 | NCB31CK-104X | C CAPACITOR | | | | D 501 | 1SR154-400-X | DIODE | | |
| | C 408 | NEA70JM-226X | E CAPACITOR | | | | IC 1 | MM3023DN-X | IC | | |
| | C 409 | NCB31CK-104X | C CAPACITOR | | | | IC101 | AN8702FH | IC | | |
| | C 410 | NCB31CK-104X | C CAPACITOR | | | | IC102 | MM3023DN-X | IC | | |
| | C 411 | NCB31CK-104X | C CAPACITOR | | | | IC201 | MN67706ZY | IC | | |
| | C 412 | NCB31CK-104X | C CAPACITOR | | | | IC271 | M56788FP-W | IC | | |
| | C 421 | NCB31CK-104X | C CAPACITOR | | | | IC301 | MN103S13BDA | IC | | |
| | C 422 | NCB31CK-104X | C CAPACITOR | | | | IC311 | TC7SH08FU-X | IC | | |
| | C 501 | NCB31CK-104X | C CAPACITOR | | | | IC312 | TC7SH32FU-X | IC | | |
| | C 502 | NCB31CK-104X | C CAPACITOR | | | | IC321 | TC7WH74FU-X | IC | | |
| | C 503 | NCB31CK-104X | C CAPACITOR | | | | IC322 | TC74VHC00FT-X | IC | | |
| | C 504 | NCB31CK-104X | C CAPACITOR | | | | IC401 | MN102L62GEJ2 | IC | OTP | |
| | C 505 | NCB31CK-104X | C CAPACITOR | | | | IC402 | MR27V1602ECJMAX | IC | | |
| | C 506 | NCB31CK-104X | C CAPACITOR | | | | IC403 | AK93C65AF-X | IC | | |
| | C 507 | NCB31CK-104X | C CAPACITOR | | | | IC411 | TC74VHC125FT-X | IC | | |
| | C 508 | NCB31CK-104X | C CAPACITOR | | | | IC412 | TC7WT125FU-X | IC(DIGITAL) | | |
| | C 509 | NCB31CK-104X | C CAPACITOR | | | | IC501 | ZIVA-4.1-PB0 | IC | | |
| | C 510 | NCB31CK-104X | C CAPACITOR | | | | IC502 | NAX0393-001X | IC | 27MHZ | |
| | C 511 | NCB31CK-104X | C CAPACITOR | | | | IC503 | TC74VHC00FT-X | IC | | |
| | C 512 | NCB31CK-104X | C CAPACITOR | | | | IC504 | W981616AH-7 | IC | | |
| | C 513 | NCB31CK-104X | C CAPACITOR | | | | IC505 | W981616AH-7 | IC | | |
| | C 514 | NCB31CK-104X | C CAPACITOR | | | | K 102 | NQR0398-002X | FERRITE BEADS | | |
| | C 515 | NCB31CK-104X | C CAPACITOR | | | | K 103 | NQR0398-002X | FERRITE BEADS | | |
| | C 516 | NCB31CK-104X | C CAPACITOR | | | | K 201 | NQR0398-002X | FERRITE BEADS | | |
| | C 517 | NCB31CK-104X | C CAPACITOR | | | | K 202 | NQR0398-002X | FERRITE BEADS | | |
| | C 518 | NCB31CK-104X | C CAPACITOR | | | | K 203 | NQR0398-002X | FERRITE BEADS | | |
| | C 519 | NCB31CK-104X | C CAPACITOR | | | | K 301 | NQR0398-002X | FERRITE BEADS | | |
| | C 520 | NCB31CK-104X | C CAPACITOR | | | | K 302 | NQR0398-002X | FERRITE BEADS | | |
| | C 521 | NCB31CK-104X | C CAPACITOR | | | | K 303 | NQR0398-002X | FERRITE BEADS | | |
| | C 522 | NCB31CK-104X | C CAPACITOR | | | | K 401 | NQR0398-002X | FERRITE BEADS | | |
| | C 523 | NCB31CK-104X | C CAPACITOR | | | | K 402 | NQR0398-002X | FERRITE BEADS | | |
| | C 524 | NCB31CK-104X | C CAPACITOR | | | | K 501 | NQR0398-002X | FERRITE BEADS | | |
| | C 525 | NCB31CK-104X | C CAPACITOR | | | | K 502 | NQR0398-002X | FERRITE BEADS | | |
| | C 526 | NCB31CK-104X | C CAPACITOR | | | | K 503 | NQR0398-002X | FERRITE BEADS | | |
| | C 527 | NCB31CK-104X | C CAPACITOR | | | | K 504 | NQR0398-003X | FERRITE BEADS | | |
| | C 528 | NCB31CK-104X | C CAPACITOR | | | | K 505 | NQR0427-003X | FERRITE BEADS | | |
| | C 529 | NCB31CK-104X | C CAPACITOR | | | | K 506 | NQR0398-002X | FERRITE BEADS | | |
| | C 530 | NEA70JM-107X | E CAPACITOR | | | | K 551 | NQR0398-002X | FERRITE BEADS | | |
| | C 531 | NCB31CK-104X | C CAPACITOR | | | | K 553 | NQR0398-002X | FERRITE BEADS | | |
| | C 532 | NCB31CK-104X | C CAPACITOR | | | | K 554 | NRSA02J-0R0X | MG RESISTOR | | |
| | C 533 | NCB31CK-104X | C CAPACITOR | | | | K 555 | NQR0398-002X | FERRITE BEADS | | |
| | C 534 | NEA70JM-107X | E CAPACITOR | | | | K 556 | NQR0398-002X | FERRITE BEADS | | |
| | C 535 | NCB31CK-104X | C CAPACITOR | | | | K 558 | NQR0398-002X | FERRITE BEADS | | |
| | C 536 | NCB31CK-103X | C CAPACITOR | | | | K 561 | NQR0398-002X | FERRITE BEADS | | |
| | C 537 | NEA70JM-226X | E CAPACITOR | | | | L 1 | NQL044K-100X | INDUCTOR | | |
| | C 538 | NCB31CK-104X | C CAPACITOR | | | | Q 1 | KTC4377/C/-X | POW TRANSISTOR | | |
| | C 539 | NCB31CK-104X | C CAPACITOR | | | | Q 101 | KTA1001/Y/-X | TRANSISTOR | | |
| | C 540 | NEA70JM-226X | E CAPACITOR | | | | Q 102 | KTA1001/Y/-X | TRANSISTOR | | |
| | C 541 | NCB31CK-104X | C CAPACITOR | | | | Q 275 | DTC144EE-X | TRANSISTOR | | |
| | C 542 | NEA70JM-226X | E CAPACITOR | | | | Q 401 | DTC144EE-X | TRANSISTOR | | |
| | C 543 | NCB31CK-104X | C CAPACITOR | | | | Q 402 | DTC144EE-X | TRANSISTOR | | |
| | C 544 | NCB31CK-104X | C CAPACITOR | | | | Q 403 | DTC144EE-X | TRANSISTOR | | |

■ Electrical parts list (DVD servo board)

Block No. 05

| ▲ | Item | Parts number | Parts name | Remarks | Area |
|---|-------|--------------|-------------|---------|------|
| | R 1 | NRSA63J-100X | MG RESISTOR | | |
| | R 103 | NRS125J-270X | MG RESISTOR | | |
| | R 104 | NRS125J-270X | MG RESISTOR | | |
| | R 107 | NRSA63J-0R0X | MG RESISTOR | | |
| | R 108 | NRSA63J-183X | MG RESISTOR | | |
| | R 109 | NRSA63J-0R0X | MG RESISTOR | | |
| | R 110 | NRSA63J-273X | MG RESISTOR | | |
| | R 111 | NRSA63J-0R0X | MG RESISTOR | | |
| | R 112 | NRSA63J-273X | MG RESISTOR | | |
| | R 113 | NRSA63J-682X | MG RESISTOR | | |
| | R 114 | NRSA63J-102X | MG RESISTOR | | |
| | R 115 | NRVA63D-243X | MG RESISTOR | | |
| | R 116 | NRSA63J-393X | MG RESISTOR | | |
| | R 117 | NRSA63J-123X | MG RESISTOR | | |
| | R 118 | NRSA63J-223X | MG RESISTOR | | |
| | R 121 | NRSA63J-0R0X | MG RESISTOR | | |
| | R 122 | NRSA63J-0R0X | MG RESISTOR | | |
| | R 123 | NRSA63J-0R0X | MG RESISTOR | | |
| | R 124 | NRSA63J-0R0X | MG RESISTOR | | |
| | R 125 | NRSA63J-0R0X | MG RESISTOR | | |
| | R 126 | NRSA63J-0R0X | MG RESISTOR | | |
| | R 127 | NRSA63J-222X | MG RESISTOR | | |
| | R 128 | NRSA63J-105X | MG RESISTOR | | |
| | R 129 | NRSA63J-105X | MG RESISTOR | | |
| | R 131 | NRSA63J-822X | MG RESISTOR | | |
| | R 132 | NRSA63J-103X | MG RESISTOR | | |
| | R 144 | NRSA63J-333X | MG RESISTOR | | |
| | R 145 | NRSA63J-103X | MG RESISTOR | | |
| | R 152 | NRS125J-1R0X | MG RESISTOR | | |
| | R 153 | NRS125J-4R7X | MG RESISTOR | | |
| | R 155 | NRSA63J-0R0X | MG RESISTOR | | |
| | R 156 | NRSA63J-333X | MG RESISTOR | | |
| | R 160 | NRSA63J-0R0X | MG RESISTOR | | |
| | R 161 | NRSA63J-0R0X | MG RESISTOR | | |
| | R 162 | NRSA63J-0R0X | MG RESISTOR | | |
| | R 163 | NRSA63J-0R0X | MG RESISTOR | | |
| | R 166 | NRSA63J-182X | MG RESISTOR | | |
| | R 202 | NRSA63J-473X | MG RESISTOR | | |
| | R 203 | NRSA63J-473X | MG RESISTOR | | |
| | R 204 | NRSA63J-473X | MG RESISTOR | | |
| | R 205 | NRSA63J-473X | MG RESISTOR | | |
| | R 208 | NRSA63J-473X | MG RESISTOR | | |
| | R 209 | NRSA63J-123X | MG RESISTOR | | |
| | R 210 | NRSA63J-473X | MG RESISTOR | | |
| | R 211 | NRSA63J-273X | MG RESISTOR | | |
| | R 212 | NRSA63J-273X | MG RESISTOR | | |
| | R 213 | NRSA63J-562X | MG RESISTOR | | |
| | R 214 | NRSA63J-123X | MG RESISTOR | | |
| | R 215 | NRSA63J-105X | MG RESISTOR | | |
| | R 218 | NRSA63J-153X | MG RESISTOR | | |
| | R 219 | NRSA63J-473X | MG RESISTOR | | |
| | R 220 | NRSA63J-473X | MG RESISTOR | | |
| | R 223 | NRSA63J-473X | MG RESISTOR | | |
| | R 225 | NRSA63J-682X | MG RESISTOR | | |
| | R 227 | NRSA63J-102X | MG RESISTOR | | |
| | R 228 | NRSA63J-183X | MG RESISTOR | | |
| | R 229 | NRSA63J-273X | MG RESISTOR | | |
| | R 230 | NRSA63J-273X | MG RESISTOR | | |
| | R 232 | NRSA63J-472X | MG RESISTOR | | |
| | R 233 | NRSA63J-472X | MG RESISTOR | | |
| | R 234 | NRSA63J-472X | MG RESISTOR | | |
| | R 235 | NRSA63J-0R0X | MG RESISTOR | | |
| | R 237 | NRSA63J-221X | MG RESISTOR | | |

| ▲ | Item | Parts number | Parts name | Remarks | Area |
|---|-------|--------------|-------------|---------|------|
| | R 238 | NRSA63J-221X | MG RESISTOR | | |
| | R 239 | NRSA63J-221X | MG RESISTOR | | |
| | R 240 | NRSA63J-221X | MG RESISTOR | | |
| | R 241 | NRSA63J-221X | MG RESISTOR | | |
| | R 242 | NRSA63J-102X | MG RESISTOR | | |
| | R 243 | NRSA63J-102X | MG RESISTOR | | |
| | R 244 | NRSA63J-102X | MG RESISTOR | | |
| | R 245 | NRSA63J-102X | MG RESISTOR | | |
| | R 246 | NRSA63J-102X | MG RESISTOR | | |
| | R 248 | NRSA63J-473X | MG RESISTOR | | |
| | R 249 | NRSA63J-473X | MG RESISTOR | | |
| | R 250 | NRSA63J-473X | MG RESISTOR | | |
| | R 253 | NRS125J-4R7X | MG RESISTOR | | |
| | R 255 | NRSA63J-123X | MG RESISTOR | | |
| | R 256 | NRSA63J-0R0X | MG RESISTOR | | |
| | R 257 | NRSA63J-0R0X | MG RESISTOR | | |
| | R 258 | NRSA63J-0R0X | MG RESISTOR | | |
| | R 261 | NRSA63J-0R0X | MG RESISTOR | | |
| | R 271 | NRSA63J-563X | MG RESISTOR | | |
| | R 272 | NRSA63J-103X | MG RESISTOR | | |
| | R 273 | NRS125J-1R0X | MG RESISTOR | | |
| | R 274 | NRSA63J-0R0X | MG RESISTOR | | |
| | R 275 | NRSA63J-103X | MG RESISTOR | | |
| | R 276 | NRSA63J-103X | MG RESISTOR | | |
| | R 277 | NRSA63J-103X | MG RESISTOR | | |
| | R 278 | NRSA63J-103X | MG RESISTOR | | |
| | R 279 | NRSA63J-103X | MG RESISTOR | | |
| | R 280 | NRSA63J-103X | MG RESISTOR | | |
| | R 282 | NRSA63J-103X | MG RESISTOR | | |
| | R 283 | NRSA63J-103X | MG RESISTOR | | |
| | R 284 | NRSA63J-472X | MG RESISTOR | | |
| | R 285 | NRSA63J-103X | MG RESISTOR | | |
| | R 286 | NRSA63J-103X | MG RESISTOR | | |
| | R 287 | NRSA63J-103X | MG RESISTOR | | |
| | R 288 | NRSA63J-103X | MG RESISTOR | | |
| | R 289 | NRSA63J-103X | MG RESISTOR | | |
| | R 290 | NRSA63J-103X | MG RESISTOR | | |
| | R 292 | NRSA63J-223X | MG RESISTOR | | |
| | R 295 | NRSA63J-103X | MG RESISTOR | | |
| | R 296 | NRSA63J-103X | MG RESISTOR | | |
| | R 297 | NRS125J-1R0X | MG RESISTOR | | |
| | R 301 | NRSA63J-473X | MG RESISTOR | | |
| | R 302 | NRSA63J-473X | MG RESISTOR | | |
| | R 303 | NRSA63J-473X | MG RESISTOR | | |
| | R 304 | NRSA63J-473X | MG RESISTOR | | |
| | R 305 | NRSA63J-473X | MG RESISTOR | | |
| | R 306 | NRSA63J-473X | MG RESISTOR | | |
| | R 307 | NRSA63J-473X | MG RESISTOR | | |
| | R 308 | NRSA63J-473X | MG RESISTOR | | |
| | R 309 | NRSA63J-103X | MG RESISTOR | | |
| | R 310 | NRSA63J-102X | MG RESISTOR | | |
| | R 311 | NRSA63J-102X | MG RESISTOR | | |
| | R 312 | NRSA63J-102X | MG RESISTOR | | |
| | R 316 | NRSA63J-105X | MG RESISTOR | | |
| | R 317 | NRSA63J-0R0X | MG RESISTOR | | |
| | R 318 | NRSA63J-0R0X | MG RESISTOR | | |
| | R 322 | NRSA63J-473X | MG RESISTOR | | |
| | R 324 | NRSA63J-473X | MG RESISTOR | | |
| | R 328 | NRSA63J-473X | MG RESISTOR | | |
| | R 342 | NRSA63J-0R0X | MG RESISTOR | | |
| | R 343 | NRSA63J-102X | MG RESISTOR | | |
| | R 345 | NRSA63J-562X | MG RESISTOR | | |
| | R 346 | NRSA63J-472X | MG RESISTOR | | |

■ Electrical parts list (DVD servo board)

Block No. 05

| △ | Item | Parts number | Parts name | Remarks | Area |
|---|-------|--------------|-------------|-----------------|-------|
| | R 347 | NRSA63J-102X | MG RESISTOR | | |
| | R 348 | NRSA63J-102X | MG RESISTOR | | |
| | R 349 | NRSA63J-102X | MG RESISTOR | | |
| | R 350 | NRSA63J-102X | MG RESISTOR | | |
| | R 364 | NRSA63J-0R0X | MG RESISTOR | | |
| | R 403 | NRSA63J-472X | MG RESISTOR | | |
| | R 405 | NRSA63J-472X | MG RESISTOR | | |
| | R 408 | NRSA63J-472X | MG RESISTOR | | |
| | R 411 | NRSA63J-472X | MG RESISTOR | | |
| | R 412 | NRSA63J-103X | MG RESISTOR | | |
| | R 413 | NRSA63J-472X | MG RESISTOR | | |
| | R 414 | NRSA63J-472X | MG RESISTOR | | |
| | R 415 | NRSA63J-472X | MG RESISTOR | | |
| | R 416 | NRSA63J-472X | MG RESISTOR | | |
| | R 417 | NRSA63J-472X | MG RESISTOR | | |
| | R 418 | NRSA63J-472X | MG RESISTOR | | |
| | R 421 | NRSA63J-0R0X | MG RESISTOR | | US,UN |
| | R 422 | NRSA63J-0R0X | MG RESISTOR | | UX |
| | R 424 | NRSA63J-0R0X | MG RESISTOR | | |
| | R 425 | NRSA63J-0R0X | MG RESISTOR | 6CH CHIP SELECT | |
| | R 426 | NRSA63J-0R0X | MG RESISTOR | KARAOKE CHIP | |
| | R 431 | NRSA63J-472X | MG RESISTOR | | |
| | R 432 | NRSA63J-472X | MG RESISTOR | | |
| | R 435 | NRSA63J-103X | MG RESISTOR | | |
| | R 436 | NRSA63J-103X | MG RESISTOR | | |
| | R 437 | NRSA63J-103X | MG RESISTOR | | |
| | R 501 | NRSA63J-102X | MG RESISTOR | | |
| | R 502 | NRSA63J-472X | MG RESISTOR | | |
| | R 504 | NRSA63J-330X | MG RESISTOR | | |
| | R 506 | NRSA63J-330X | MG RESISTOR | | |
| | R 507 | NRSA63J-330X | MG RESISTOR | | |
| | R 508 | NRSA63J-330X | MG RESISTOR | | |
| | R 509 | NRSA63J-330X | MG RESISTOR | | |
| | R 510 | NRSA63J-330X | MG RESISTOR | | |
| | R 511 | NRSA63J-330X | MG RESISTOR | | |
| | R 512 | NRSA63J-330X | MG RESISTOR | | |
| | R 513 | NRSA63J-330X | MG RESISTOR | | |
| | R 514 | NRSA63J-330X | MG RESISTOR | | |
| | R 515 | NRSA63J-330X | MG RESISTOR | | |
| | R 516 | NRSA63J-330X | MG RESISTOR | | |
| | R 517 | NRSA63J-330X | MG RESISTOR | | |
| | R 518 | NRSA63J-330X | MG RESISTOR | | |
| | R 519 | NRSA63J-330X | MG RESISTOR | | |
| | R 520 | NRSA63J-330X | MG RESISTOR | | |
| | R 521 | NRSA63J-330X | MG RESISTOR | | |
| | R 522 | NRSA63J-330X | MG RESISTOR | | |
| | R 524 | NRSA63J-181X | MG RESISTOR | | |
| | R 525 | NRSA63J-181X | MG RESISTOR | | |
| | R 526 | NRSA63J-181X | MG RESISTOR | | |
| | R 527 | NRSA63J-181X | MG RESISTOR | | |
| | R 528 | NRSA63J-102X | MG RESISTOR | | |
| | R 529 | NRSA63J-181X | MG RESISTOR | | |
| | R 530 | NRSA63J-0R0X | MG RESISTOR | | |
| | R 531 | NRSA63J-330X | MG RESISTOR | | |
| | R 532 | NRSA63J-102X | MG RESISTOR | | |
| | R 533 | NRSA63J-330X | MG RESISTOR | | |
| | R 534 | NRSA63J-330X | MG RESISTOR | | |
| | R 535 | NRSA63J-330X | MG RESISTOR | | |
| | R 536 | NRSA63J-330X | MG RESISTOR | | |
| | R 537 | NRSA63J-330X | MG RESISTOR | | |
| | R 538 | NRSA63J-330X | MG RESISTOR | | |
| | R 539 | NRSA63J-330X | MG RESISTOR | | |
| | R 540 | NRSA63J-330X | MG RESISTOR | | |

| △ | Item | Parts number | Parts name | Remarks | Area |
|---|-------|--------------|-------------|------------|------|
| | R 541 | NRSA63J-0R0X | MG RESISTOR | | |
| | R 542 | NRSA63J-0R0X | MG RESISTOR | | |
| | R 543 | NRSA63J-0R0X | MG RESISTOR | | |
| | R 545 | NRSA63J-472X | MG RESISTOR | | |
| | R 546 | NRSA63J-181X | MG RESISTOR | | |
| | R 549 | NRSA63J-0R0X | MG RESISTOR | | |
| | R 562 | NRSA63J-181X | MG RESISTOR | | |
| | R 563 | NRSA63J-181X | MG RESISTOR | | |
| | R1201 | NRSA63J-183X | MG RESISTOR | | |
| | X 301 | NAX0375-001X | CRYSTAL | 16.9344MHZ | |
| | X 401 | NAX0331-001X | C RESONATOR | | |

■ Electrical parts list (Tuner board)

Block No. 06

| △ | Item | Parts number | Parts name | Remarks | Area |
|---|------|----------------|-----------------|---------------|------|
| | C 1 | NCB21HK-223X | C CAPACITOR | | |
| | C 2 | NCB21HK-103X | C CAPACITOR | | |
| | C 3 | EETC1CM-106ZJC | E CAPACITOR | | |
| | C 4 | NCB21HK-103X | C CAPACITOR | | |
| | C 6 | NCB21HK-102X | C CAPACITOR | | |
| | C 7 | NCB21HK-102X | C CAPACITOR | | |
| | C 8 | NCB21HK-102X | C CAPACITOR | | |
| | C 10 | NRSA02J-0R0X | MG RESISTOR | | |
| | C 11 | NCB21HK-104X | C CAPACITOR | | |
| | C 12 | NCB21HK-473X | C CAPACITOR | | |
| | C 13 | NCS21HJ-120X | C CAPACITOR | | |
| | C 14 | QEKC1AM-107Z | E CAPACITOR | 100MF 20% 10V | |
| | C 15 | NCS21HJ-120X | C CAPACITOR | | |
| | C 16 | NCS21HJ-120X | C CAPACITOR | | |
| | C 17 | NCB21HK-392X | C CAPACITOR | | |
| | C 18 | QEQ61HM-474Z | NP E CAPACITOR | .47MF 20% 50V | |
| | C 19 | NCB21HK-473X | C CAPACITOR | | |
| | C 20 | NCB21HK-102X | C CAPACITOR | | |
| | C 21 | NCB21HK-223X | C CAPACITOR | | |
| | C 22 | NCS21HJ-151X | C CAPACITOR | | |
| | C 23 | NCS21HJ-151X | C CAPACITOR | | |
| | C 24 | NCS21HJ-151X | C CAPACITOR | | |
| | C 25 | QEKC1AM-107Z | E CAPACITOR | 100MF 20% 10V | |
| | C 26 | NCB21HK-102X | C CAPACITOR | | |
| | C 27 | NCB21HK-102X | C CAPACITOR | | |
| | C 30 | EETC1CM-107ZJC | E CAPACITOR | | |
| | C 31 | EEKC1CM-226ZJC | E CAPACITOR | | |
| | C 32 | NCB21HK-473X | C CAPACITOR | | |
| | C 33 | NCB21HK-473X | C CAPACITOR | | |
| | C 34 | NCB21HK-223X | C CAPACITOR | | |
| | C 35 | NCB21HK-473X | C CAPACITOR | | |
| | C 36 | EEKC1HM-105ZJC | E CAPACITOR | | |
| | C 37 | EEKC1HM-105ZJC | E CAPACITOR | | |
| | C 38 | EETC1HM-224ZJC | E CAPACITOR | | |
| | C 39 | EETC1HM-105ZJC | E CAPACITOR | | |
| | C 40 | QETN1CM-106Z | E CAPACITOR | 10MF 20% 16V | |
| | C 41 | QETN1CM-106Z | E CAPACITOR | 10MF 20% 16V | |
| | C 42 | NCB21HK-152X | C CAPACITOR | | |
| | C 43 | NCB21HK-152X | C CAPACITOR | | |
| | C 44 | QETN1CM-106Z | E CAPACITOR | 10MF 20% 16V | |
| | C 45 | QETN1CM-106Z | E CAPACITOR | 10MF 20% 16V | |
| | C 46 | NCB21HK-273X | C CAPACITOR | | |
| | C 47 | EETC1HM-105ZJC | E CAPACITOR | | |
| | C 48 | NCB21HK-222X | C CAPACITOR | | |
| | C 49 | NCS21HJ-471X | C CAPACITOR | | |
| | C 50 | EETC1CM-226ZJC | E CAPACITOR | | |
| | C 51 | EEKC1HM-105ZJC | E CAPACITOR | | |
| | C 52 | QFVJ1HJ-274Z | MF CAPACITOR | .27MF 5% 50V | |
| | C 53 | EETC1CM-226ZJC | E CAPACITOR | | |
| | C 54 | NCB21HK-473X | C CAPACITOR | | |
| | C 57 | NCB21HK-102X | C CAPACITOR | | |
| | C 58 | NCB21HK-473X | C CAPACITOR | | |
| | C 59 | NCB21HK-102X | C CAPACITOR | | |
| | CF 1 | QAX0677-001Z | C FILTER | | |
| | CF 2 | QAX0677-001Z | C FILTER | | |
| | CF 3 | QAX0610-001Z | C DISCRIMINATOR | | |
| | CN 1 | QGF1205F1-09 | CONNECTOR | | |
| | D 1 | 1SS133-T2 | SI DIODE | | |
| | D 2 | 1SS133-T2 | SI DIODE | | |
| | D 3 | 1SS133-T2 | SI DIODE | | |
| | D 4 | 1SS133-T2 | SI DIODE | | |
| | D 11 | 1SS133-T2 | SI DIODE | | |
| | IC 1 | LA1838 | IC | | |

| △ | Item | Parts number | Parts name | Remarks | Area |
|---|------|----------------|--------------|------------|------|
| | IC 2 | LC72136N | IC | | |
| | J 1 | QNB0014-001 | ANT TERMINAL | | |
| | L 1 | QQR0796-002 | COIL BLOCK | | |
| | Q 1 | 2SC2814/4-5/-X | TRANSISTOR | | |
| | Q 5 | KRA107S-X | TRANSISTOR | | |
| | R 1 | QRE141J-560Y | C RESISTOR | 56 5% 1/4W | |
| | R 2 | NRSA02J-331X | MG RESISTOR | | |
| | R 3 | NRSA02J-224X | MG RESISTOR | | |
| | R 4 | NRSA02J-331X | MG RESISTOR | | |
| | R 5 | NRSA02J-560X | MG RESISTOR | | |
| | R 6 | NRSA02J-240X | MG RESISTOR | | |
| | R 10 | NRSA02J-222X | MG RESISTOR | | |
| | R 13 | NRSA02J-103X | MG RESISTOR | | |
| | R 14 | NRSA02J-104X | MG RESISTOR | | |
| | R 15 | NRSA02J-332X | MG RESISTOR | | |
| | R 16 | NRSA02J-472X | MG RESISTOR | | |
| △ | R 17 | QRZ9005-680X | F RESISTOR | 68 1/4W | |
| | R 18 | NRSA02J-102X | MG RESISTOR | | |
| | R 19 | NRSA02J-102X | MG RESISTOR | | |
| | R 20 | NRSA02J-102X | MG RESISTOR | | |
| | R 21 | NRSA02J-562X | MG RESISTOR | | |
| | R 22 | NRSA02J-472X | MG RESISTOR | | |
| | R 23 | NRSA02J-182X | MG RESISTOR | | |
| | R 24 | NRSA02J-103X | MG RESISTOR | | |
| | R 25 | NRSA02J-331X | MG RESISTOR | | |
| | R 26 | NRSA02J-222X | MG RESISTOR | | |
| | R 27 | NRSA02J-103X | MG RESISTOR | | |
| | R 28 | NRSA02J-103X | MG RESISTOR | | |
| | R 29 | NRSA02J-103X | MG RESISTOR | | |
| | R 30 | NRSA02J-122X | MG RESISTOR | | |
| | R 31 | NRSA02J-102X | MG RESISTOR | | |
| | R 32 | NRSA02J-102X | MG RESISTOR | | |
| | R 33 | NRSA02J-331X | MG RESISTOR | | |
| | R 34 | NRSA02J-470X | MG RESISTOR | | |
| | R 35 | NRSA02J-562X | MG RESISTOR | | |
| | R 36 | NRSA02J-332X | MG RESISTOR | | |
| | R 37 | NRSA02J-103X | MG RESISTOR | | |
| | R 38 | NRSA02J-563X | MG RESISTOR | | |
| | R 39 | NRSA02J-563X | MG RESISTOR | | |
| | R 40 | NRSA02J-243X | MG RESISTOR | | |
| | R 41 | NRSA02J-332X | MG RESISTOR | | |
| | R 60 | NRSA02J-0R0X | MG RESISTOR | | |
| | T 1 | QQR0793-001 | IFT | | |
| | TU 1 | QAU0161-001 | FRONT END | | |
| | X 1 | QAX0402-001 | CRYSTAL | | |

■ Electrical parts list (DVD traverse board) Block No. 07

| △ | Item | Parts number | Parts name | Remarks | Area |
|---|-------|---------------|-----------------|----------|------|
| | C 13 | NCS31HJ-101X | C.CAPA. C.M | | |
| | CN 10 | QGF0501F4-40X | FFC/FPC CONNE | FOR MAIN | |
| | CN 12 | QGF1012F1-30X | FPC CONNE | FOR P.U | |
| | IC 1 | GP2S60B-X | IC(PHOTO COUPLE | | |
| | K 10 | NQR0265-003X | FERRITE BEADS | | |
| | K 11 | NQR0265-003X | FERRITE BEADS | | |
| | K 12 | NQR0265-003X | FERRITE BEADS | | |
| | K 13 | NQR0265-003X | FERRITE BEADS | | |
| | K 14 | NQR0265-003X | FERRITE BEADS | | |
| | K 15 | NQR0265-003X | FERRITE BEADS | | |
| | K 16 | NQR0265-003X | FERRITE BEADS | | |
| | K 17 | NQR0265-003X | FERRITE BEADS | | |
| | K 18 | NQR0265-003X | FERRITE BEADS | | |
| | R 10 | NRSA63J-391X | MG RESISTOR | | |
| | R 11 | NRSA63J-910X | MG RESISTOR | | |
| | R 12 | NRSA63J-911X | MG RESISTOR | | |
| | S 10 | QSW0620-001 | SWITCH | REST SW | |
| | S 11 | NSW0127-001X | SLIDE SWITCH | SHORT SW | |

■ Electrical parts list (DVD changer board) Block No. 08

| △ | Item | Parts number | Parts name | Remarks | Area |
|---|-------|----------------|---------------|----------------|------|
| | C 801 | QEKC1AM-107Z | E.CAPACITOR | 100MF 20% 10V | |
| | C 802 | QEKC1EM-475Z | E.CAPACITOR | 4.7MF 20% 25V | |
| | C 803 | QFLC1HJ-102Z | M CAPACITOR | 1000PF 5% 50V | |
| | C 804 | QCFB1HZ-104Y | C CAPACITOR | .10MF +80:-20% | |
| | C 805 | QDYB1CM-103Y | C.CAPACITOR | | |
| | C 806 | QEKC1CM-476Z | E.CAPACITOR | 47MF 20% 16V | |
| | C 807 | QEKC1CM-476Z | E.CAPACITOR | 47MF 20% 16V | |
| | C 808 | QFLC1HJ-102Z | M CAPACITOR | 1000PF 5% 50V | |
| | C 810 | QCZ0205-155Z | ML C CAPA I/M | 1.5MF | |
| | C 811 | QCZ0205-155Z | ML C CAPA I/M | 1.5MF | |
| | C 813 | QDYB1CM-103Y | C.CAPACITOR | | |
| | C 821 | QDGB1HK-102Y | C CAPACITOR | | |
| | CN801 | QGF1205F1-10 | CONNECTOR | TO MICON | |
| | CN802 | QGB2016K1-07 | CONNECTOR | TO SWITCH PWB | |
| | CN803 | QGB2012K2-10 | CONNECTOR | TO CAM SW PWB | |
| | IC801 | UPD65612GB-208 | IC | | |
| △ | IC802 | TA8409S | IC | | |
| △ | IC803 | TA8409S | IC | | |
| | L 801 | QQL231K-100Y | INDUCTOR | | |
| | L 802 | QQL01BK-100Z | INDUCTOR | | |
| | L 803 | QQL01BK-100Z | INDUCTOR | | |
| | L 804 | QQL01BK-100Z | INDUCTOR | | |
| | R 805 | QRE141J-102Y | C RESISTOR | 1.0K 5% 1/4W | |
| | R 806 | QRE141J-471Y | C RESISTOR | 470 5% 1/4W | |
| | R 807 | QRE141J-471Y | C RESISTOR | 470 5% 1/4W | |
| | R 808 | QRE141J-102Y | C RESISTOR | 1.0K 5% 1/4W | |
| | R 810 | QRE141J-684Y | C RESISTOR | 680K 5% 1/4W | |
| | R 811 | QRE141J-105Y | C RESISTOR | 1.0M 5% 1/4W | |
| | R 813 | QRE141J-102Y | C RESISTOR | 1.0K 5% 1/4W | |
| | R 814 | QRE141J-102Y | C RESISTOR | 1.0K 5% 1/4W | |
| | R 815 | QRE141J-102Y | C RESISTOR | 1.0K 5% 1/4W | |
| | R 816 | QRE141J-102Y | C RESISTOR | 1.0K 5% 1/4W | |
| | R 817 | QRE141J-102Y | C RESISTOR | 1.0K 5% 1/4W | |
| | R 818 | QRE141J-102Y | C RESISTOR | 1.0K 5% 1/4W | |
| | R 819 | QRE141J-102Y | C RESISTOR | 1.0K 5% 1/4W | |
| | R 820 | QRE141J-102Y | C RESISTOR | 1.0K 5% 1/4W | |
| | R 821 | QRE141J-102Y | C RESISTOR | 1.0K 5% 1/4W | |
| | R 822 | QRE141J-102Y | C RESISTOR | 1.0K 5% 1/4W | |
| | R 823 | QRE141J-102Y | C RESISTOR | 1.0K 5% 1/4W | |
| | R 824 | QRE141J-102Y | C RESISTOR | 1.0K 5% 1/4W | |
| | R 825 | QRE141J-102Y | C RESISTOR | 1.0K 5% 1/4W | |
| | R 826 | QRE141J-102Y | C RESISTOR | 1.0K 5% 1/4W | |
| | R 827 | QRE141J-102Y | C RESISTOR | 1.0K 5% 1/4W | |
| | R 828 | QRE141J-102Y | C RESISTOR | 1.0K 5% 1/4W | |
| | R 829 | QRE141J-102Y | C RESISTOR | 1.0K 5% 1/4W | |
| | R 830 | QRE141J-102Y | C RESISTOR | 1.0K 5% 1/4W | |
| | R 832 | QRE141J-181Y | C RESISTOR | 180 5% 1/4W | |
| | R 833 | QRE141J-102Y | C RESISTOR | 1.0K 5% 1/4W | |
| | R 834 | QRE141J-102Y | C RESISTOR | 1.0K 5% 1/4W | |
| | R 838 | QRE141J-272Y | C RESISTOR | 2.7K 5% 1/4W | |
| | R 839 | QRE141J-332Y | C RESISTOR | 3.3K 5% 1/4W | |
| | R 840 | QRE141J-562Y | C RESISTOR | 5.6K 5% 1/4W | |

■ Electrical parts list (DVD switch board) Block No. 09

| △ | Item | Parts number | Parts name | Remarks | Area |
|---|-------|--------------|---------------|---------|------|
| | CN804 | QGB2016J1-07 | CONNECTOR | | |
| | CN805 | QGB2012J1-10 | CONNECTOR | | |
| | SW 1 | QSW0859-001 | DETECT SWITCH | | |
| | SW 2 | QSW0859-001 | DETECT SWITCH | | |
| | SW 3 | QSW0859-001 | DETECT SWITCH | | |
| | SW 4 | QSW0859-001 | DETECT SWITCH | | |
| | SW 5 | QSW0859-001 | DETECT SWITCH | | |
| | SW 6 | QSW0859-001 | DETECT SWITCH | | |

■ Electrical parts list
(Head amplifier & mechanism control board) Block No. 10

| △ | Item | Parts number | Parts name | Remarks | Area | △ | Item | Parts number | Parts name | Remarks | Area |
|---|-------|----------------|-----------------|----------------|------|---|-------|---------------|----------------|------------------|------|
| | CN301 | QGF1205F1-06 | CONNECTOR | A HEAD | | | D3302 | 1SR139-400-T2 | SI DIODE | | |
| | CN302 | QGF1205F1-06 | CONNECTOR | B HEAD | | | D3307 | DZ5.1BSB-T2 | Z DIODE | NEW SUPPLIER | |
| | CN303 | QGB2011M1-10 | B TO B CONNECTO | | | | D3308 | DZ5.1BSB-T2 | Z DIODE | | |
| | CN305 | QGF1201F3-10 | CONNECTOR | OUTPUT | | | D3309 | DZ5.1BSB-T2 | Z DIODE | | |
| | CN306 | QGF1205F1-09 | CONNECTOR | CONTROL | | | D3331 | 1SR139-400-T2 | SI DIODE | | |
| | CN333 | QGB2011L1-10 | B TO B CONNECTO | FOR FMP-007-1 | | | FW301 | EWR34D-10CS | FLAT WIRE | TO MOTOR CONTROL | |
| | C3101 | QCSB1HJ-100Y | C CAPACITOR | 10PF 5% 50V | | | IC301 | BA3126N | IC | HEAD SW | |
| | C3102 | QCBB1HK-331Y | C CAPACITOR | 330PF 10% 50V | | | IC302 | AN7345K | IC | PRE AMP | |
| | C3103 | QDGB1HK-821Y | C CAPACITOR | | | | IC303 | CD4094BC | IC | | |
| | C3104 | QDGB1HK-102Y | C CAPACITOR | | | | IC331 | SG-105F3-BB,C | PHOTO SENSER | | |
| | C3105 | EEKJ1AM-107ZJC | AL E CAPACITOR | | | | IC332 | SG-105F3-BB,C | PHOTO SENSER | | |
| | C3107 | EEKJ1HM-105ZJC | AL E CAPACITOR | | | | L3202 | QQR0621-001Z | FERRITE BEADS | | |
| | C3111 | EEKJ1HM-104ZJC | AL E CAPACITOR | | | | L3301 | QQR1118-002 | BIAS COIL | OSC COIL | |
| | C3112 | EEKJ1CM-106ZJC | AL E CAPACITOR | | | | L3303 | QLL244K-100Z | INDUCTOR | | |
| | C3113 | QDXB1CM-332Y | C CAPACITOR | | | | P3302 | QNZ0104-001 | POST PIN | | |
| | C3114 | EEKJ1EM-475ZJC | AL E CAPACITOR | | | | P3331 | QNZ0104-001 | POST PIN | | |
| | C3115 | QFLK1HJ-153Z | M CAPACITOR | .015MF 5% 50V | | | Q3105 | 2SC3576-JVC-T | TRANSISTOR | | |
| | C3116 | QDYB1CM-822Y | C CAPACITOR | | | | Q3205 | 2SC3576-JVC-T | TRANSISTOR | | |
| | C3119 | QFLM1HJ-563Z | M CAPACITOR | .056MF 5% 50V | | | Q3302 | 2SC2001/K-T | TRANSISTOR | | |
| | C3120 | QCSB1HJ-330Y | C CAPACITOR | 33PF 5% 50V | | | Q3305 | 2SC2001/K-T | TRANSISTOR | | |
| | C3121 | QDGB1HK-102Y | C CAPACITOR | | | | Q3312 | 2SB562/C-T | TRANSISTOR | | |
| | C3201 | QCSB1HJ-100Y | C CAPACITOR | 10PF 5% 50V | | | Q3313 | KTC3199/GL-T | TRANSISTOR | | |
| | C3202 | QCBB1HK-331Y | C CAPACITOR | 330PF 10% 50V | | | Q3314 | 2SB562/C-T | TRANSISTOR | | |
| | C3203 | QDGB1HK-821Y | C CAPACITOR | | | | Q3315 | KTC3199/GL-T | TRANSISTOR | | |
| | C3204 | QDGB1HK-102Y | C CAPACITOR | | | | Q3316 | KTA1267/YG-T | TRANSISTOR | | |
| | C3205 | EEKJ1AM-107ZJC | AL E CAPACITOR | | | | Q3317 | KRC107M-T | D TRANSISTOR | | |
| | C3206 | QFLK1HJ-333Z | M CAPACITOR | .033MF 5% 50V | | | Q3323 | KRC104M-T | D TRANSISTOR | | |
| | C3207 | EEKJ1HM-105ZJC | AL E CAPACITOR | | | | Q3324 | KRA102M-T | D TRANSISTOR | | |
| | C3211 | EEKJ1HM-104ZJC | AL E CAPACITOR | | | | R3103 | QRE141J-183Y | C RESISTOR | 18K 5% 1/4W | |
| | C3212 | EEKJ1CM-106ZJC | AL E CAPACITOR | | | | R3105 | QRE141J-220Y | C RESISTOR | 22 5% 1/4W | |
| | C3213 | QDXB1CM-332Y | C CAPACITOR | | | | R3106 | QRE141J-392Y | C RESISTOR | 3.9K 5% 1/4W | |
| | C3214 | EEKJ1EM-475ZJC | AL E CAPACITOR | | | | R3107 | QRE141J-222Y | C RESISTOR | 2.2K 5% 1/4W | |
| | C3215 | QFLK1HJ-153Z | M CAPACITOR | .015MF 5% 50V | | | R3108 | QRE141J-241Y | C RESISTOR | 240 5% 1/4W | |
| | C3216 | QDYB1CM-822Y | C CAPACITOR | | | | R3111 | QRE141J-562Y | C RESISTOR | 5.6K 5% 1/4W | |
| | C3219 | QFLM1HJ-563Z | M CAPACITOR | .056MF 5% 50V | | | R3112 | QRE141J-102Y | C RESISTOR | 1.0K 5% 1/4W | |
| | C3220 | QCSB1HJ-330Y | C CAPACITOR | 33PF 5% 50V | | | R3113 | QRE141J-271Y | C RESISTOR | 270 5% 1/4W | |
| | C3221 | QDGB1HK-102Y | C CAPACITOR | | | | R3114 | QRE141J-391Y | C RESISTOR | 390 5% 1/4W | |
| | C3222 | QFLK1HJ-333Z | M CAPACITOR | .033MF 5% 50V | | | R3117 | QRE141J-332Y | C RESISTOR | 3.3K 5% 1/4W | |
| | C3301 | EEKJ1AM-107ZJC | AL E CAPACITOR | | | | R3118 | QRE141J-152Y | C RESISTOR | 1.5K 5% 1/4W | |
| | C3302 | EEKJ1AM-107ZJC | AL E CAPACITOR | | | | R3119 | QRE141J-203Y | C RESISTOR | 20K 5% 1/4W | |
| | C3303 | EEKJ1CM-226ZJC | AL E CAPACITOR | | | | R3120 | QRE141J-102Y | C RESISTOR | 1.0K 5% 1/4W | |
| | C3304 | EEKJ1EM-475ZJC | AL E CAPACITOR | | | | R3121 | QRE141J-122Y | C RESISTOR | 1.2K 5% 1/4W | |
| | C3305 | QFLK1HJ-393Z | M CAPACITOR | .039MF 5% 50V | | | R3203 | QRE141J-183Y | C RESISTOR | 18K 5% 1/4W | |
| | C3306 | EEKJ0JM-227ZJC | AL E CAPACITOR | | | | R3205 | QRE141J-220Y | C RESISTOR | 22 5% 1/4W | |
| | C3308 | QDXB1CM-152Y | C CAPACITOR | | | | R3206 | QRE141J-392Y | C RESISTOR | 3.9K 5% 1/4W | |
| | C3313 | EEKJ1AM-107ZJC | AL E CAPACITOR | | | | R3207 | QRE141J-222Y | C RESISTOR | 2.2K 5% 1/4W | |
| | C3314 | QCZ0202-155Z | ML C CAPACITOR | 1.5MF | | | R3208 | QRE141J-241Y | C RESISTOR | 240 5% 1/4W | |
| | C3315 | QCBB1HK-223Y | C CAPACITOR | .022MF 10% 50V | | | R3211 | QRE141J-562Y | C RESISTOR | 5.6K 5% 1/4W | |
| | C3316 | QFG32AJ-103Z | PP CAPACITOR | .010MF 5% 100V | | | R3212 | QRE141J-102Y | C RESISTOR | 1.0K 5% 1/4W | |
| | C3327 | EEKJ1CM-476ZJC | AL E CAPACITOR | | | | R3213 | QRE141J-271Y | C RESISTOR | 270 5% 1/4W | |
| | C3335 | QDYB1CM-103Y | C CAPACITOR | | | | R3214 | QRE141J-391Y | C RESISTOR | 390 5% 1/4W | |
| | C3336 | QDYB1CM-103Y | C CAPACITOR | | | | R3217 | QRE141J-332Y | C RESISTOR | 3.3K 5% 1/4W | |
| | C3339 | EEKJ1CM-476ZJC | AL E CAPACITOR | | | | R3218 | QRE141J-152Y | C RESISTOR | 1.5K 5% 1/4W | |
| | C3340 | QDYB1CM-103Y | C CAPACITOR | | | | R3219 | QRE141J-203Y | C RESISTOR | 20K 5% 1/4W | |
| | C3341 | EEKJ1AM-107ZJC | AL E CAPACITOR | | | | R3220 | QRE141J-102Y | C RESISTOR | 1.0K 5% 1/4W | |
| | C3342 | EEKJ1EM-475ZJC | AL E CAPACITOR | | | | R3221 | QRE141J-122Y | C RESISTOR | 1.2K 5% 1/4W | |
| | C3345 | QCBB1HK-331Y | C CAPACITOR | 330PF 10% 50V | | | R3301 | QRE141J-221Y | C RESISTOR | 220 5% 1/4W | |
| | C3350 | QDGB1HK-102Y | C CAPACITOR | | | | R3302 | QRE141J-101Y | C RESISTOR | 100 5% 1/4W | |
| | C3501 | QDGB1HK-821Y | C CAPACITOR | | | | R3304 | QRE141J-393Y | C RESISTOR | 39K 5% 1/4W | |
| | C3502 | QCBB1HK-271Y | C CAPACITOR | 270PF 10% 50V | | | R3309 | QRE141J-152Y | C RESISTOR | 1.5K 5% 1/4W | |
| | C3555 | QDGB1HK-102Y | C CAPACITOR | | | | R3311 | QRJ146J-4R7X | UNF C RESISTOR | 4.7 5% 1/4W | |
| | C3601 | QDGB1HK-821Y | C CAPACITOR | | | | R3314 | QRE141J-101Y | C RESISTOR | 100 5% 1/4W | |
| | C3602 | QCBB1HK-271Y | C CAPACITOR | 270PF 10% 50V | | | R3315 | QRE141J-153Y | C RESISTOR | 15K 5% 1/4W | |

■ Electrical parts list
(Head amplifier & mechanism control board) Block No. 10

| △ | Item | Parts number | Parts name | Remarks | Area |
|---|-------|--------------|-----------------|--------------|------|
| | R3327 | QRE141J-474Y | C RESISTOR | 470K 5% 1/4W | |
| | R3330 | QRE141J-103Y | C RESISTOR | 10K 5% 1/4W | |
| | R3331 | QRE141J-103Y | C RESISTOR | 10K 5% 1/4W | |
| | R3335 | QRE141J-222Y | C RESISTOR | 2.2K 5% 1/4W | |
| | R3336 | QRE141J-392Y | C RESISTOR | 3.9K 5% 1/4W | |
| | R3344 | QRE141J-224Y | C RESISTOR | 220K 5% 1/4W | |
| | R3345 | QRE141J-473Y | C RESISTOR | 47K 5% 1/4W | |
| | R3347 | QRE141J-392Y | C RESISTOR | 3.9K 5% 1/4W | |
| | R3348 | QRE141J-222Y | C RESISTOR | 2.2K 5% 1/4W | |
| | R3350 | QRE141J-472Y | C RESISTOR | 4.7K 5% 1/4W | |
| | R3351 | QRE141J-151Y | C RESISTOR | 150 5% 1/4W | |
| | R3353 | QRE141J-472Y | C RESISTOR | 4.7K 5% 1/4W | |
| | R3354 | QRE141J-151Y | C RESISTOR | 150 5% 1/4W | |
| | R3355 | QRE141J-332Y | C RESISTOR | 3.3K 5% 1/4W | |
| | R3359 | QRE141J-103Y | C RESISTOR | 10K 5% 1/4W | |
| | R3361 | QRE141J-393Y | C RESISTOR | 39K 5% 1/4W | |
| | R3362 | QRE141J-243Y | C RESISTOR | 24K 5% 1/4W | |
| | R3366 | QRE141J-273Y | C RESISTOR | 27K 5% 1/4W | |
| | R3367 | QRE141J-103Y | C RESISTOR | 10K 5% 1/4W | |
| | R3368 | QRE141J-223Y | C RESISTOR | 22K 5% 1/4W | |
| | R3369 | QRE141J-101Y | C RESISTOR | 100 5% 1/4W | |
| | R3370 | QRE141J-103Y | C RESISTOR | 10K 5% 1/4W | |
| | R3374 | QRE141J-2R2Y | C RESISTOR | 2.2 5% 1/4W | |
| △ | R3376 | QRZ9005-100X | F RESISTOR | 10 1W | |
| | R3377 | QRE141J-470Y | C RESISTOR | 47 5% 1/4W | |
| | R3378 | QRE141J-470Y | C RESISTOR | 47 5% 1/4W | |
| | R3379 | QRE141J-203Y | C RESISTOR | 20K 5% 1/4W | |
| | R3380 | QRE141J-470Y | C RESISTOR | 47 5% 1/4W | |
| | R3381 | QRE141J-470Y | C RESISTOR | 47 5% 1/4W | |
| | R3383 | QRE141J-471Y | C RESISTOR | 470 5% 1/4W | |
| | SW302 | QSW0832-001 | LEAF SWITCH | | |
| | SW303 | QSW0832-001 | LEAF SWITCH | | |
| | SW304 | QSW0832-001 | LEAF SWITCH | | |
| | SW305 | QSW0832-001 | LEAF SWITCH | | |
| | SW306 | QSW0859-001 | SW | | |
| | SW316 | QSW0859-001 | SW | | |
| | VR101 | QVP0008-503Z | SEMI V RESISTOR | ALPS | |
| | VR201 | QVP0008-503Z | SEMI V RESISTOR | ALPS | |
| | VR301 | QVP0008-103Z | SEMI V RESISTOR | ALPS | |

Packing materials and accessories parts list

Block No.

| | | | |
|---|---|---|---|
| M | 3 | M | M |
|---|---|---|---|

Block No.

| | | | |
|---|---|---|---|
| M | 5 | M | M |
|---|---|---|---|

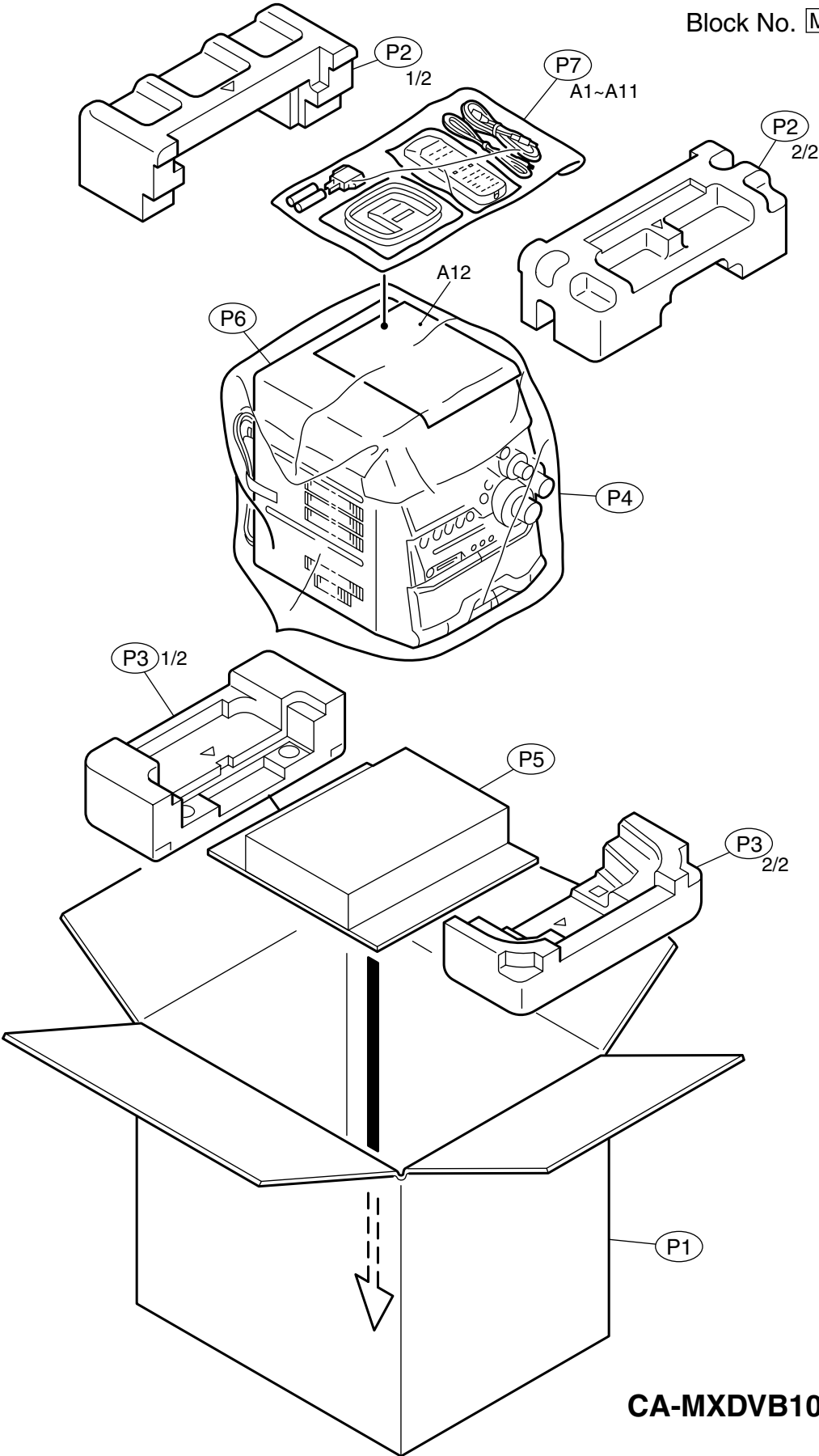

CA-MXDVB10

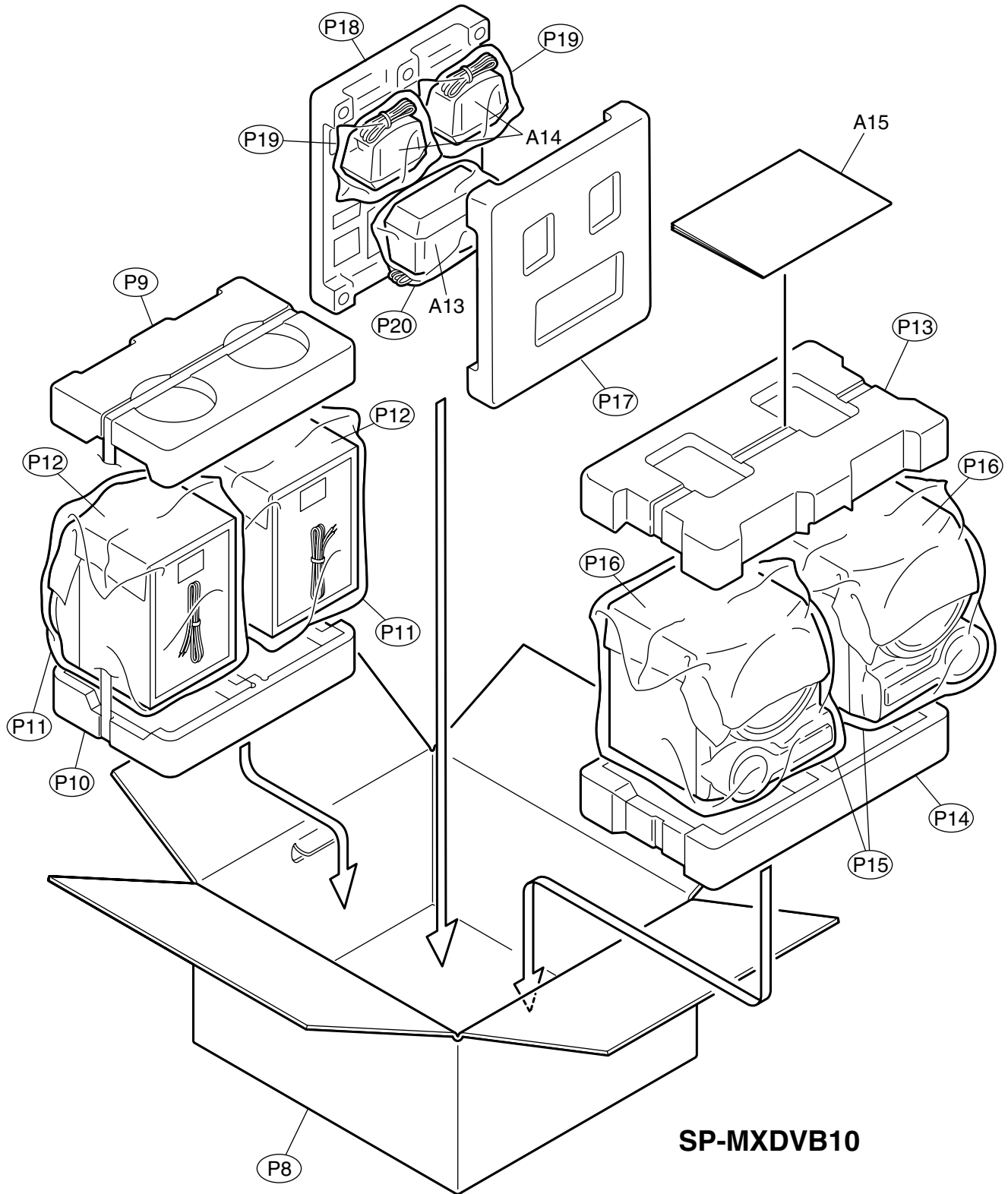

SP-MXDVB10

■ Parts list (Packing)

Block No. M3MM

| △ | Item | Parts number | Parts name | Q'ty | Description | Area |
|---|------|---------------|----------------|------|-------------|-------|
| | P 1 | GV20185-002A | PACKING CASE | 1 | CA-MXDVB10 | UX |
| | | GV20185-001A | PACKING CASE | 1 | CA-MXDVB10 | US,UN |
| | P 2 | GV10071-002A | TOP CUSHION | 1 | CA-MXDVB10 | |
| | P 3 | GV10072-002A | BOTTOM CUSHION | 1 | CA-MXDVB10 | |
| | P 4 | QPC06507015P | POLY BAG | 1 | CA-MXDVB10 | |
| | P 5 | GV30209-001A | SPACER | 1 | CA-MXDVB10 | |
| | P 6 | GV40168-003A | SHEET | 1 | CA-MXDVB10 | |
| | P 7 | QPC02503515P | POLY BAG | 1 | CA-MXDVB10 | |
| | P 8 | 140777701316 | PACKING CASE | 1 | SP-MXDVB10 | |
| | P 9 | 139764991070 | TOP CUSHION | 1 | SP-XDVB10 | |
| | P 10 | 139764991071 | BOTTOM CUSHION | 1 | SP-XDVB10 | |
| | P 11 | 138737001089 | POLY BAG | 2 | SP-XDVB10 | |
| | P 12 | 138764501088 | MIRROR MAT | 2 | SP-XDVB10 | |
| | P 13 | 139764991072 | TOP CUSHION | 1 | SP-WDVB10 | |
| | P 14 | 139764991073 | BOTTOM CUSHION | 1 | SP-WDVB10 | |
| | P 15 | 138737001089 | POLY BAG | 2 | SP-WDVB10 | |
| | P 16 | 138764501088 | MIRROR MAT | 2 | SP-WDVB10 | |
| | P 17 | 720-TDVB10-00 | TOP CUSHION | 1 | SP-DSDVB10 | |
| | P 18 | 720-BDVB10-00 | BOTTOMCUSHION | 1 | SP-DSDVB10 | |
| | P 19 | 700-120042-10 | POLY BAG | 2 | SP-XSDVB10 | |
| | P 20 | 700-120043-10 | POLY BAG | 1 | SP-XCDVB10 | |

■ Parts list (Accessories)

Block No. M5MM

| △ | Item | Parts number | Parts name | Q'ty | Description | Area |
|---|------|--------------|-----------------------|------|-----------------|-------|
| | A 1 | GVT0057-016B | INST.BOOK(CA-MXDVB10) | 1 | ENG | |
| | | GVT0057-014B | INST.BOOK(CA-MXDVB10) | 1 | ARA | UX |
| | | GVT0057-003B | INST.BOOK(CA-MXDVB10) | 1 | CHI | US,UN |
| | A 2 | GV40261-003A | NOTICE SHEET | 1 | | |
| | A 3 | GV40301-001A | MP3 SHEET | 1 | | |
| | A 4 | GV40360-001A | SPK SHEET | 1 | | |
| | A 5 | QAM0216-001 | SIGNAL CORD | 1 | | |
| | A 6 | FQAL0014-001 | AM LOOP ANT | 1 | | |
| | A 7 | EWP503-001 | ANT.WIRE | 1 | | |
| △ | A 8 | QAM0112-001 | AC PLUG ADAPTER | 1 | | US,UX |
| △ | A 9 | VMZ0139-001 | CONNECT PLUG | 1 | | UX |
| | A 10 | RM-SMXDVB10U | REMOCON | 1 | | |
| | A 11 | ----- | BATTERY | 2 | | |
| | A 12 | GV40350-003A | CAUTION SHEET | 1 | | |
| | A 13 | SP-XCDVB10K | SP BOX ASSY | 1 | SP-XCDVB10 | |
| | A 14 | SP-XSDVB10K | SP BOX ASSY | 2 | SP-XSDVB10 | |
| | A 15 | GVT0091-001A | INST.BOOK(SP-MXDVB10) | 1 | ENG,SPA,POR,CHI | |

JVC

SCHEMATIC DIAGRAMS

COMPACT COMPONENT SYSTEM

MX-DVB10

CD-ROM No.SML200209

Area suffix

US ----- Singapore
 UX ----- Saudi Arabia
 UN ----- Asean

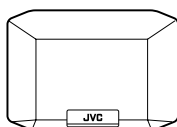

(SP-XSDVB10)
REAR

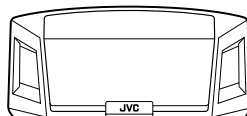

(SP-XCDVB10)
CENTER

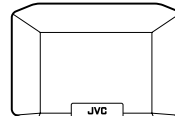

(SP-XSDVB10)
REAR

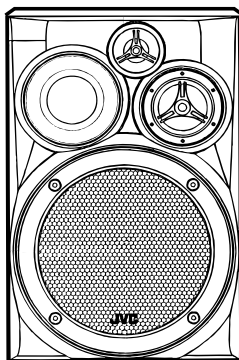

(SP-XDVB10)
MAIN

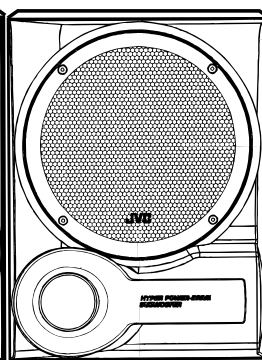

(SP-WDVB10)
SUBWOOFER

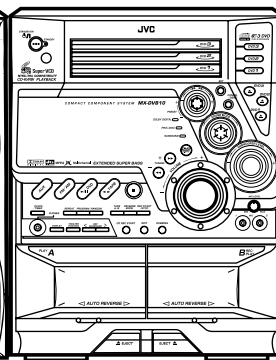

(CA-MXDVB10)

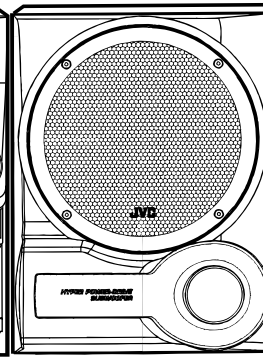

(SP-WDVB10)
SUBWOOFER

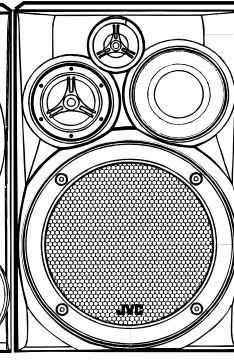

(SP-XDVB10)
MAIN



Contents

Block diagram ----- 2-1
 Standard schematic diagrams ----- 2-2
 Printed circuit boards ----- 2-11~16

MX-DVB10

In regard with component parts appearing on the silk-screen printed side (parts side) of the PWB diagrams, the parts that are printed over with black such as the resistor (■), diode (⊣) and ICP (●) or identified by the "△" mark nearby are critical for safety.

(This regulation does not correspond to J and C version.)

Block diagram

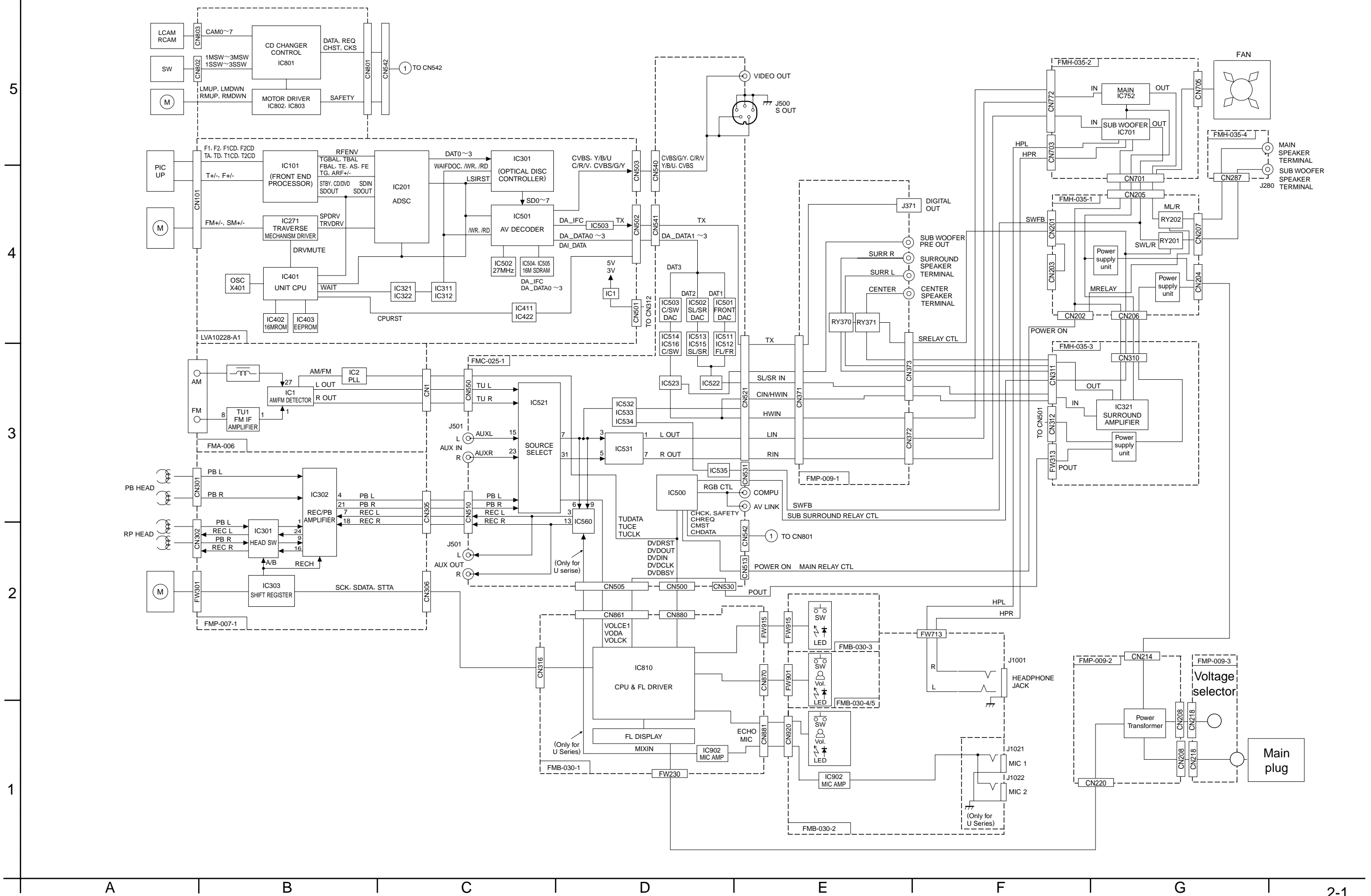

Standard schematic diagrams

■ DVD servo section (1 / 2)

LVA10228-A1

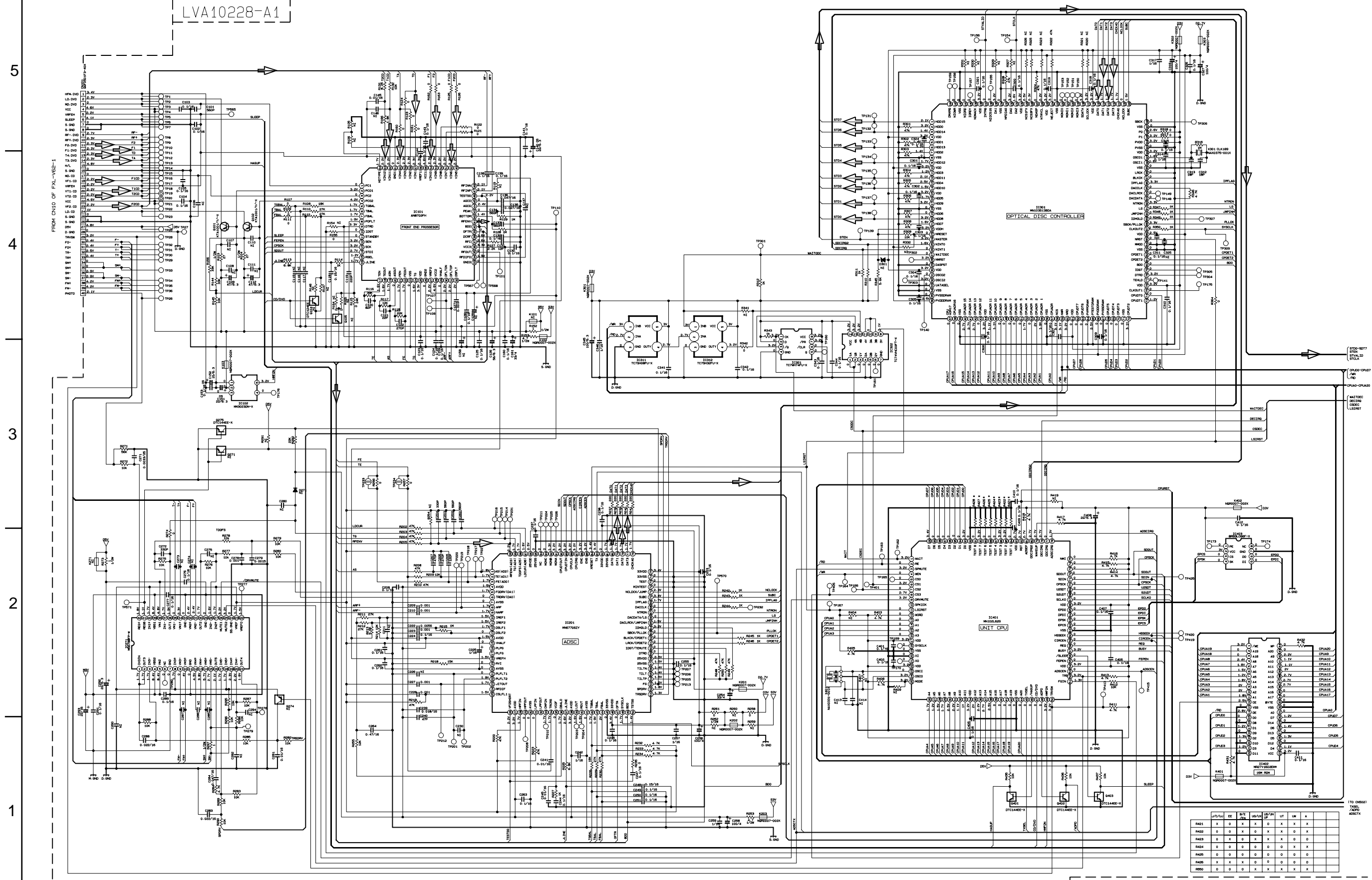

| | U/C/A/J | EE | SR | US/LM | UT | LM | A |
|------|---------|----|----|-------|----|----|---|
| RA01 | X | 0 | X | X | 0 | X | X |
| RA02 | 0 | 0 | X | 0 | X | X | 0 |
| RA03 | 0 | X | 0 | X | X | X | 0 |
| RA04 | 0 | 0 | 0 | 0 | 0 | X | X |
| RA05 | 0 | 0 | 0 | 0 | 0 | 0 | 0 |
| RA06 | X | X | X | 0 | 0 | 0 | 0 |
| RA09 | 0 | 0 | 0 | X | X | X | X |

⇨ Digital data signal

■ DVD servo section (2 / 2)

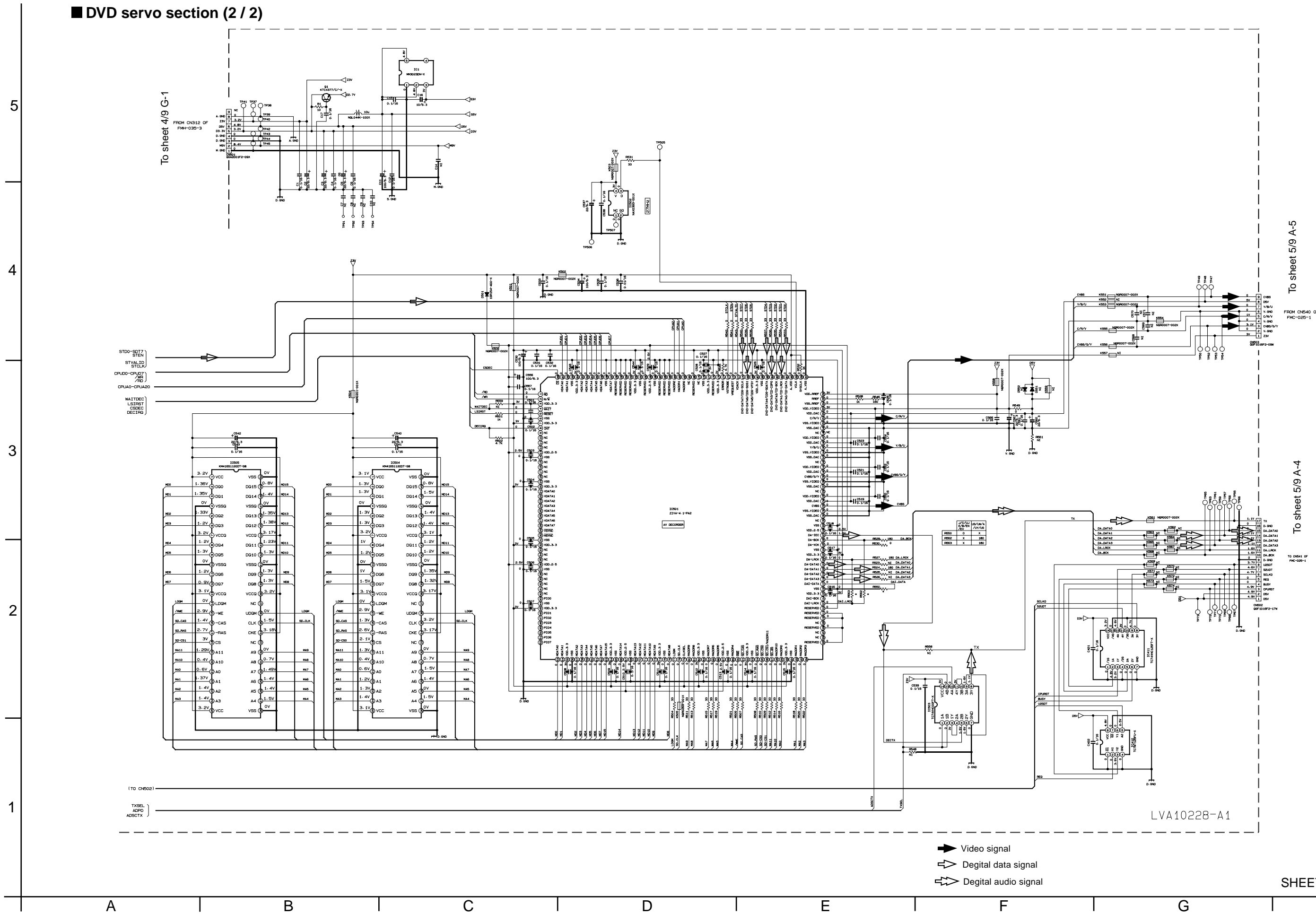

DVD changer control section

To sheet 5/9 H-4

5
4
3
2
1

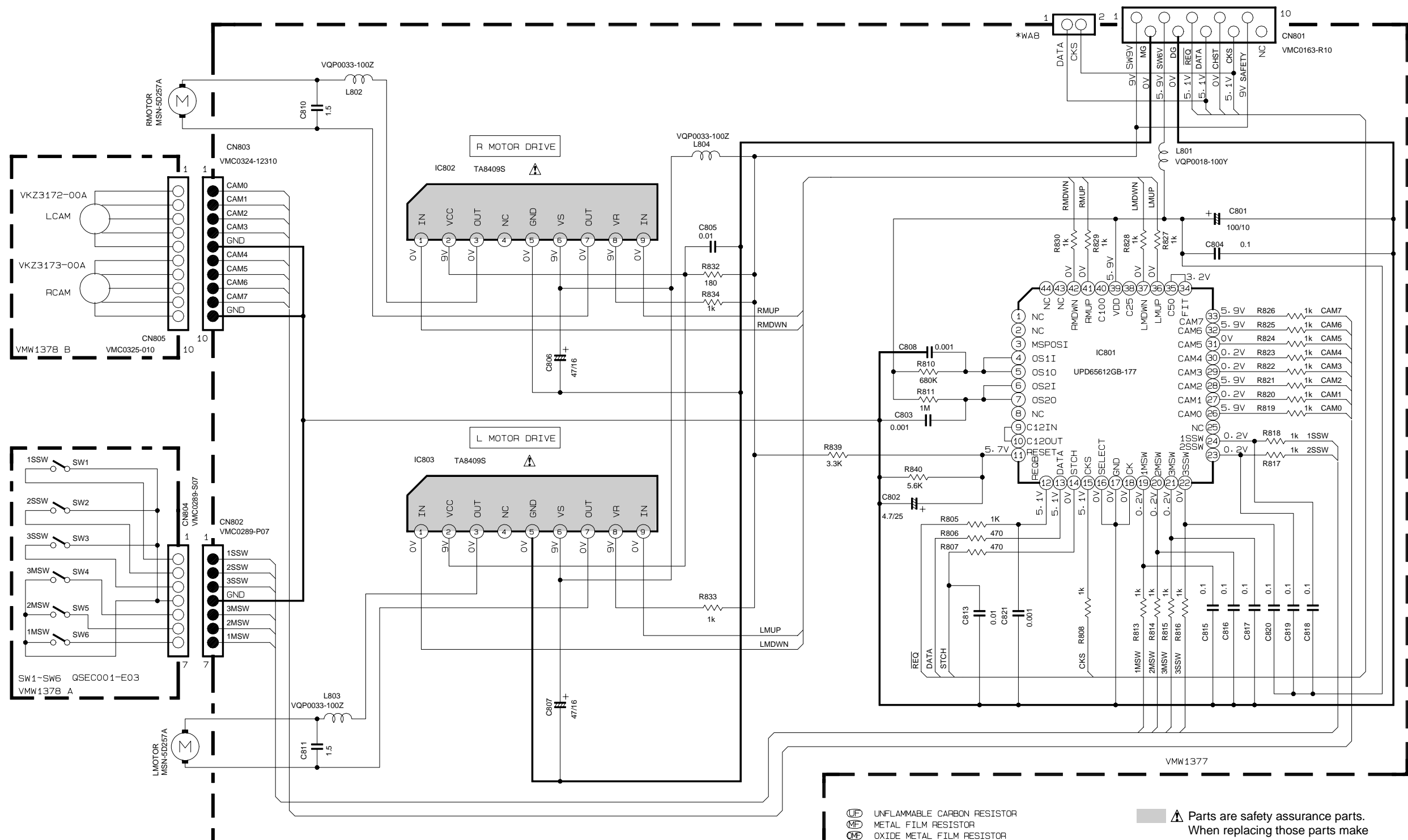

TABLE 1 CAM PATTERN LIST

| CAM NO. | LCAM | RCAM | POSITION |
|-------------|-----------|-----------|----------------|
| 0 | 1 2 3 | 4 5 6 7 | EMERGENCY |
| MAIN TRAY 1 | 0 1 1 1 0 | 1 1 1 0 | TRAY1 STAND-BY |
| SUB TRAY 1 | 0 0 1 1 0 | 1 1 0 0 | TRAY1 CHACKING |
| CAMR 1 | 0 1 0 1 0 | 1 0 1 0 | TRAY2 STAND-BY |
| MAIN TRAY 2 | 1 0 0 1 0 | 1 0 1 0 | TRAY2 CHACKING |
| SUB TRAY 2 | 1 1 1 0 0 | 0 1 1 1 | TRAY3 STAND-BY |
| CAMR 2 | 1 0 1 0 0 | 0 1 0 1 | TRAY3 CHACKING |
| MAIN TRAY 3 | 1 1 0 0 0 | 0 0 1 1 | SUB TRAY 3 |
| SUB TRAY 3 | 1 0 0 0 0 | | OFF |
| OFF | 1 1 1 1 0 | 1 1 1 1 1 | |

0=0V
1=5V

NOTES

- VOLTAGES ARE DC-MEASURED WITH A DIGITAL VOLT METER OR OSCILLOSCOPE WITHOUT INPUT SIGNAL. CONDITION --- DISC 1 CD STOP MODE
- UNLESS OTHERWISE SPECIFIED, RESISTORS ARE 1/6W ±5% CARBON RESISTOR. ALL RESISTANCE VALUES ARE IN OHM(Ω). ALL CAPACITORS ARE CERAMIC CAPACITOR OR MYLAR CAPACITOR. ALL CAPACITANCE VALUES ARE IN μF(P=pF). ALL INDUCTANCE VALUES ARE IN μH(m=mH). ALL E. CAPACITORS ARE SHOWN IN THE FORM OF CAPACITANCE (μF)/RATED VOLTAGE (V).

- UNFLAMMABLE CARBON RESISTOR
 - METAL FILM RESISTOR
 - OXIDE METAL FILM RESISTOR
 - ±20% LOW LEAK CURRENT ELECTROLYTIC CAPACITOR
 - NON-POLARISED ELECTROLYTIC CAPACITOR
 - POLYPROPYLENE CAPACITOR
 - POLYSTYROL CAPACITOR
- Parts are safety assurance parts. When replacing those parts make sure to use the specified one.

A B C 2-4 D E F G H

Amplifier section

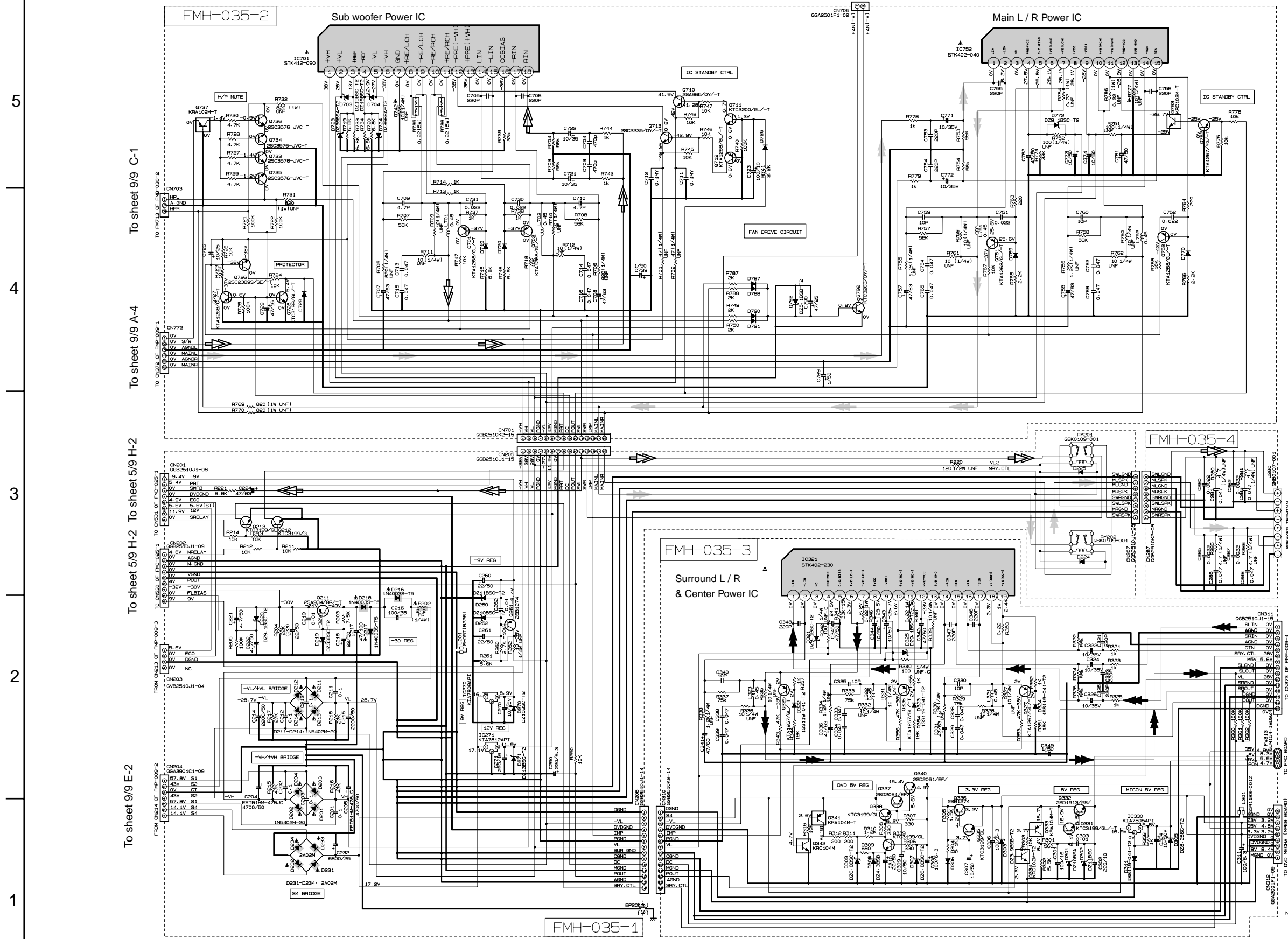

5
4
3
2
1

To sheet 9/9 C-1
To sheet 9/9 A-4
To sheet 5/9 H-2
To sheet 9/9 E-2

To sheet 9/9 F-4
To sheet 5/9 G-2
To sheet 2/9 B-5

- Subwoofer signal
- Surround signal
- Main signal
- Parts are safety assurance parts. When replacing those parts make sure to use the specified one.

NOTES
1. VOLTAGES ARE DC-MEASURED WITH A DIGITAL VOLT METER OR OSCILLOSCOPE WITHOUT INPUT SIGNAL.
CAUTION - AIR KEYS VS. NON-BUS VOLT.
2. UNLESS OTHERWISE SPECIFIED:
RESISTORS ARE 1/4W ±5% CARBON RESISTOR.
ALL RESISTANCE VALUES ARE IN OHMS UNLESS OTHERWISE SPECIFIED.
ALL CAPACITORS ARE CERAMIC CAPACITOR OR MILAR CAPACITOR.
ALL CAPACITANCE VALUES ARE IN PICO-FARAD (PF) UNLESS OTHERWISE SPECIFIED.
ALL INDUCTANCE VALUES ARE IN MILLI-HENRY (MH) UNLESS OTHERWISE SPECIFIED.
ALL ELECTROLYTIC CAPACITORS ARE IN THE FORM OF CAPACITANCE (UF) / RATED VOLTAGE (V).
ALL DIODES ARE 1S1519-T2 OR 1S1519-041-T2

AV decoder section

MX-DVB10 MX-DVB10

To sheet 6/9 A-3 To sheet 6/9 A-3 To sheet 8/9 D-1

FMC-025-1

5
4
3
2
1

To sheet 2/9 H-4
To sheet 2/9 H-3
To sheet 9/7 F-2
To sheet 4/9 G-2
To sheet 4/9 A-3
To sheet 9/9 E-4

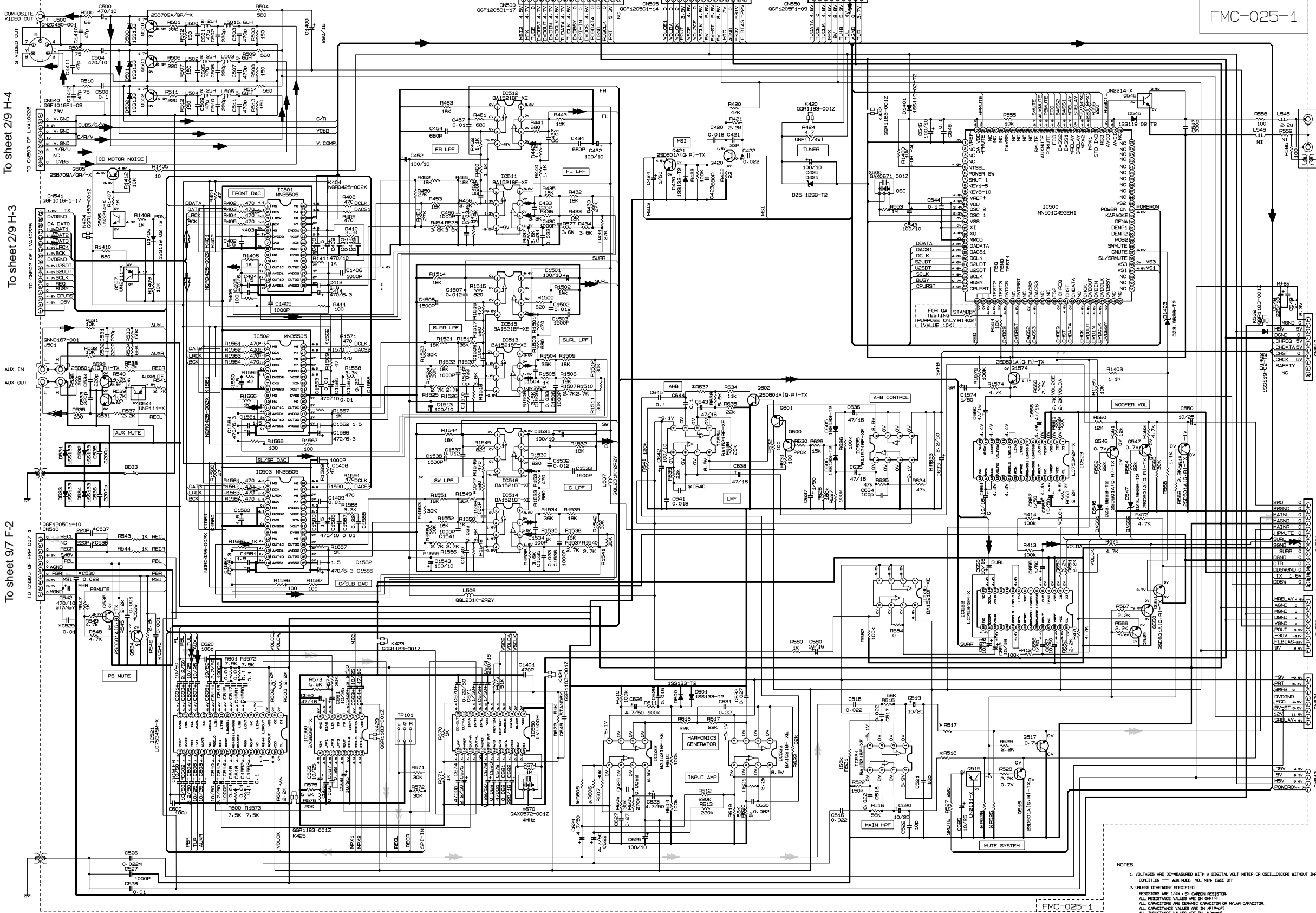

| MARK | MODEL | CA-MXDVB10 | CA-MXDVB9 | UT |
|---------------------------------|-------|--------------|--------------|--------------|
| REF NUMBER | | US/UN/UG/LX | L/UN/LX | |
| C537/C538/C539/C540/C550/C530/V | | NONE | NONE | USE |
| R623 | | 270 | 390 | 390 |
| R637 | | 4.7K | 1.8K | 1.8K |
| C640 | | GFVJ1HJ-883Z | GFVJ1HJ-224Z | GFVJ1HJ-224Z |
| R517/R518 | | 2.2K | 3.9K | 3.9K |
| R525/R526 | | 56K | 10K | 10K |
| R605/R606 | | 3.3K | 1.2K | 1.2K |

- Digital audio signal
- Video signal
- Tuner signal
- Tape PB signal
- Tape REC signal
- Aux input signal
- Aux output signal
- Surround signal
- Main signal

NOTES
 1. VOLTAGES ARE DC-MEASURED WITH A DIGITAL VOLT METER OR OSCILLOSCOPE WITHOUT INPUT SIGNAL. CONDITION — AUX MUTE, VOL, MUTE, BASS OFF.
 2. UNLESS OTHERWISE SPECIFIED, RESISTORS ARE 1/4W, 5% CARBON RESISTOR. ALL RESISTANCE VALUES ARE IN OHM (Ω). ALL CAPACITORS ARE CERAMIC CAPACITOR OR POLYMER CAPACITOR. ALL CAPACITANCE VALUES ARE IN PICO (p), NANO (n), MICRO (μ), MILLI (m), OR KILO (k). ALL INDUCTANCE VALUES ARE IN MILLI (m). ALL DIODES ARE 1SS133-T2 OR 1SS139-041-T2.

System control section

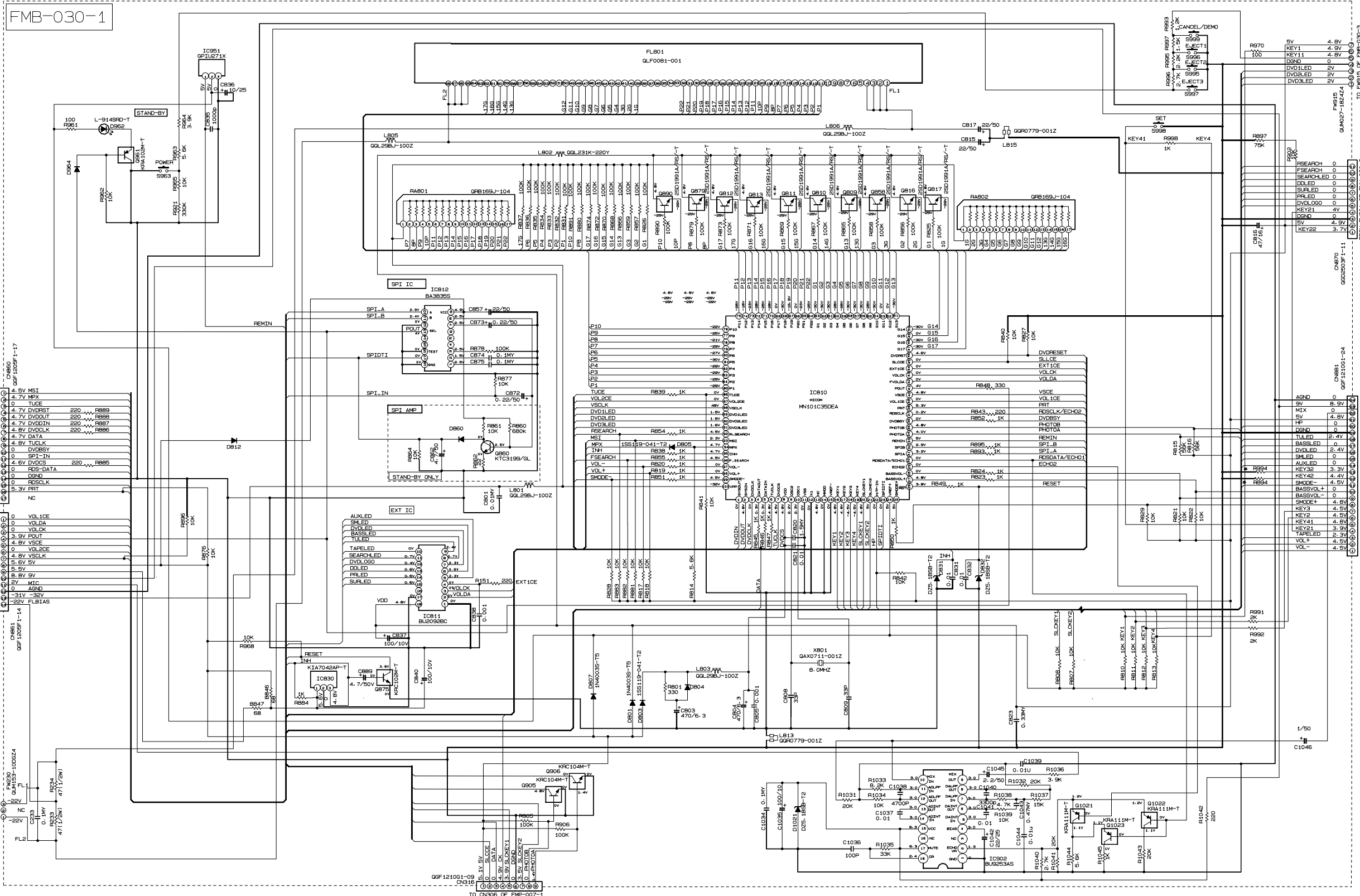

| REF. NUMBER | U/LIN/US | UG | LX | UT |
|-------------|----------|------|-----|-----|
| R994 | 75K | 330K | 18K | 18K |
| R994 | 330K | 75K | 18K | 75K |

To sheet 7/9 G-1

NOTES

1. VOLTAGES ARE DC-MEASURED WITH A DIGITAL VOLT METER OR OSCILLOSCOPE WITHOUT INPUT SIGNAL. CONDITION --- AUX. MODE: VOL. MEN. BASS OFF
2. UNLESS OTHERWISE SPECIFIED:
 - RESISTORS ARE 1/4W ± 5% CARBON RESISTOR.
 - ALL RESISTANCE VALUES ARE IN Ω/K/M.
 - ALL CAPACITORS ARE CERAMIC CAPACITOR OR MYLAR CAPACITOR.
 - ALL CAPACITANCE VALUES ARE IN #/p/f.
 - ALL CAPACITANCE VALUES ARE IN #/μ/f.
 - ALL CAPACITORS ARE SHOWN IN THE FORM OF CAPACITANCE (μF)/RATED VOLTAGE (V).
 - ALL DIODES ARE 1SS139-T2 OR 1SS119-041-T2

To sheet 5/9 C-5

To sheet 5/9 D-5

To sheet 9/9 C-1

To sheet 9/9 A-5

To sheet 9/9 A-4

To sheet 9/9 A-2

5

4

3

2

1

Head amplifier / Mechanism control section

CASSETTE MECHA CONTROL CIRCUIT [SLC]

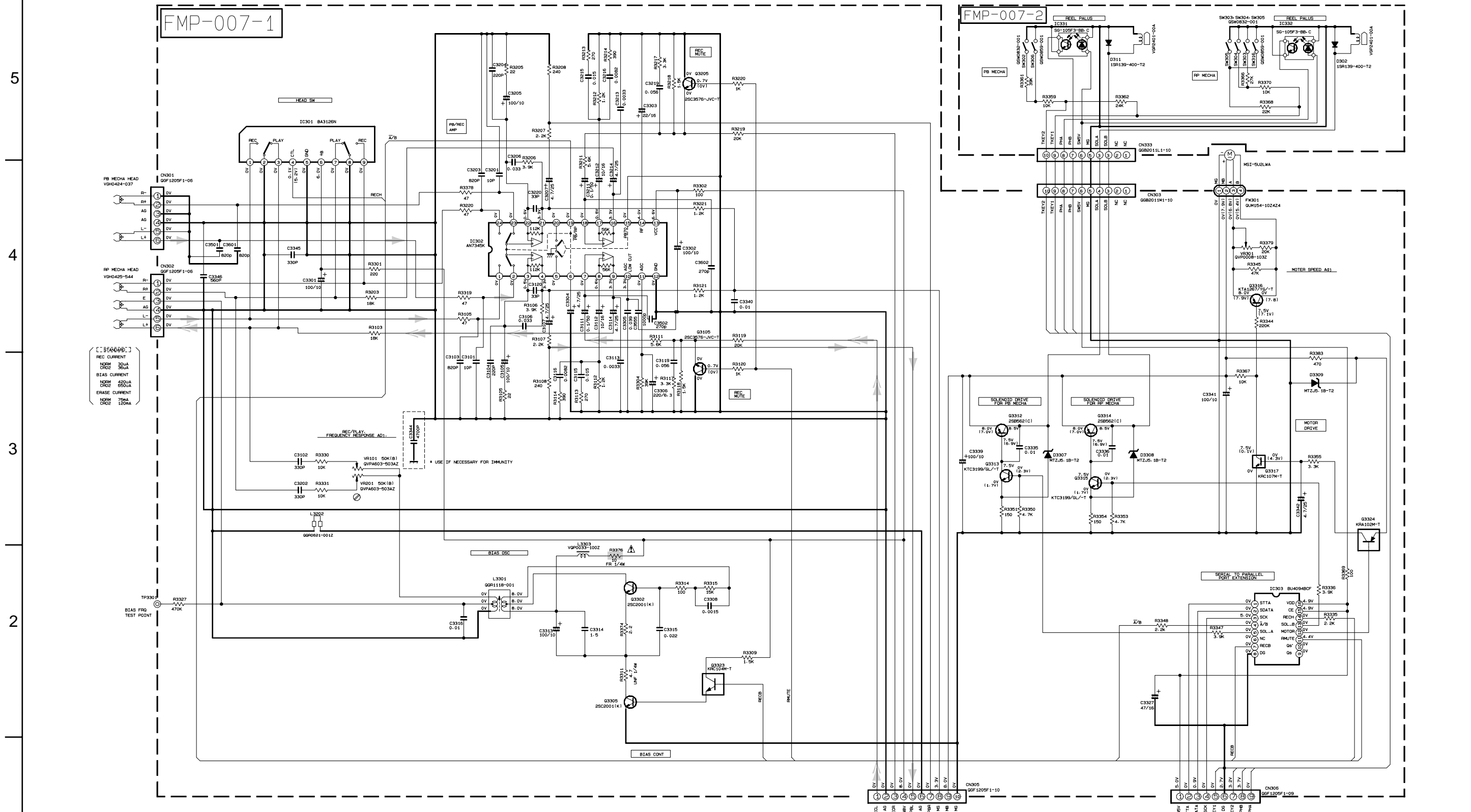

5

4

3

2

1

NOTES

1. VOLTAGES ARE DC-MEASURED WITH A DIGITAL VOLT METER OR OSCILLOSCOPE WITHOUT INPUT SIGNAL. () IS INVERT MODE

2. UNLESS OTHERWISE SPECIFIED

ALL RESISTANCE VALUES ARE IN OHM(Ω).

ALL CAPACITORS ARE CERAMIC CAPACITOR

ALL CAPACITANCE VALUES ARE IN μF(μF).

ALL INDUCTANCE VALUES ARE IN #H(μH).

ALL E. CAPACITORS ARE SHOWN IN THE FORM OF CAPACITANCE (μF)/RATED VOLTAGE (V).

PP PLYPROPYLENE CAPACITOR

➔ TAPE PB signal

➔ TAPE REC signal

⚠ Parts are safety assurance parts. When replacing those parts make sure to use the specified one.

FROM CN305 OF FMC-025-1

To sheet 5/9 A-3

FROM CN316 OF FMB-030-1

To sheet 6/9 C-1

Tuner section

NOTES

- VOLTAGES ARE DC-MEASURED WITH A DIGITAL VOLT METER.
- ALL RESISTORS ARE 1/8W ±5% METAL GLAZE RESISTOR.
- ALL RESISTANCE VALUES ARE IN OHM(Ω).
- ALL CAPASITANCE VALUES ARE IN pF(P=PF).
- ALL E. CAPASITORS ARE SHOWN IN THE FORM OF CAPASITANCE (pF)/RATED VOLTAGE (V).
- SI DIODES (▷) ARE ALL 1SS133-T THAT CAN BE CHANGED TO SIMILAR DIODE SUCH AS MA165 OR HSS104J.
- PARTS NO. OF TRANSISTORS ARE AS FOLLOWS.
 Q1 2SC2814/4-5/-X Q2, Q3 2SC2412K/R/-X
 Q4, Q5 DTA114YKA-X

B. INSIDE OF DIGITAL TRANSISTORS ARE SHOWN AS FOLLOWS:

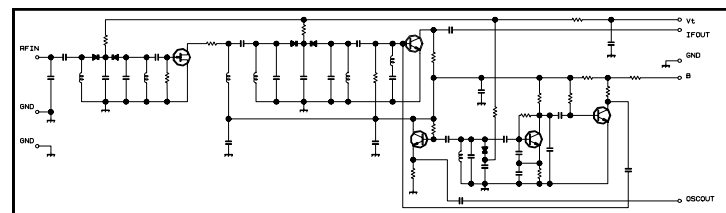
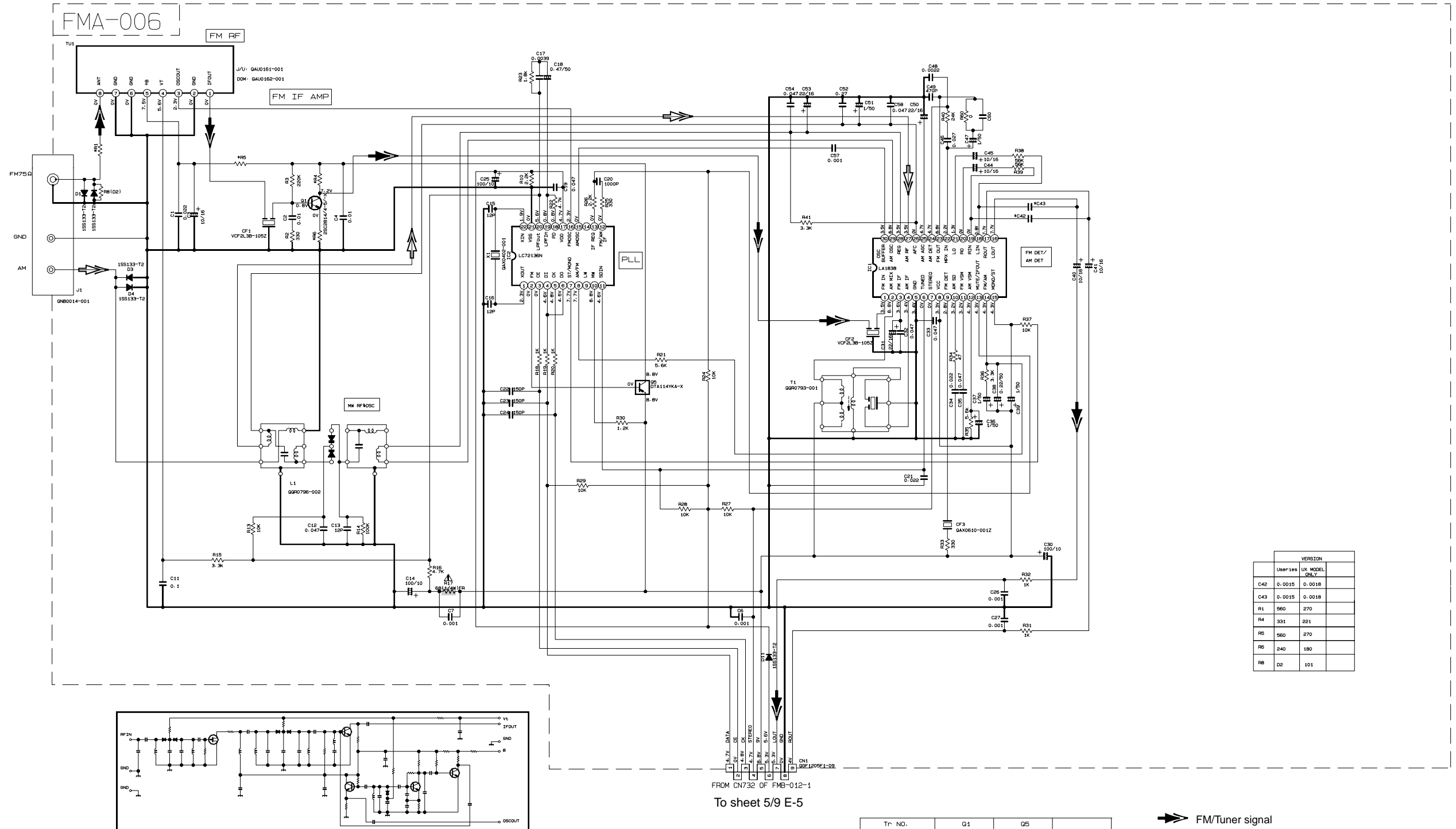
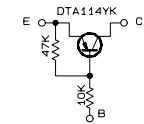

| VERSION | |
|------------|---------------|
| User's ver | UX MODEL ONLY |
| C42 | 0.0015 0.0018 |
| C43 | 0.0015 0.0018 |
| R1 | 560 270 |
| R4 | 331 221 |
| R5 | 560 270 |
| R6 | 240 180 |
| R8 | 02 101 |

| CONDITION | PIN NO. | 1 | 2 | 3 | 4 | 5 | 6 | 7 | 8 | 9 | 10 | 11 | 12 | 13 | 14 | 15 | 16 | 17 | 18 | 19 | 20 | 21 | 22 | 23 | 24 | 25 | 26 | 27 | 28 | 29 | 30 |
|-----------|----------------|-----|-----|-----|-----|-----|-----|-----|-----|-----|-----|-----|----|-----|-----|-----|-----|-----|-----|-----|-----|-----|-----|-----|-----|-----|-----|-----|-----|-----|-----|
| IC1 | FM NO SIGNAL | 3.6 | 8.9 | 3.6 | 3.6 | 0 | 5.0 | 5.0 | 8.9 | 8.9 | 1.3 | 0.1 | 0 | 0.9 | 7.8 | 7.8 | 4.3 | 4.3 | 4.3 | 4.3 | 3.4 | 3.4 | 2.8 | 3.4 | 0 | 0 | 3.5 | 3.5 | 3.6 | 3.6 | 2.7 |
| IC1 | FM 60dB STEREO | 3.6 | 8.9 | 3.6 | 3.6 | 0 | 5.0 | 5.0 | 8.9 | 8.9 | 1.3 | 4.3 | 0 | 0.9 | 7.8 | 7.8 | 4.3 | 4.3 | 4.3 | 4.3 | 3.4 | 3.4 | 2.8 | 3.4 | 0 | 0 | 3.6 | 3.6 | 3.6 | 3.6 | 2.7 |
| IC1 | AM NO SIGNAL | 3.5 | 9.0 | 3.5 | 3.5 | 0 | 5.0 | 5.1 | 9.0 | 2.6 | 1.3 | 0 | 0 | 0.9 | 4.7 | 5.5 | 4.3 | 4.3 | 4.3 | 3.3 | 3.2 | 2.8 | UBT | 0.7 | 0.7 | 3.6 | 3.6 | 3.6 | 3.6 | 2.1 | |
| IC2 | FM NO SIGNAL | 2.5 | 0 | 0 | 5.0 | 4.9 | 5.0 | 7.9 | 7.8 | 3.6 | 6.1 | 5.1 | 0 | 0 | 0 | 2.5 | 5.1 | 0.9 | 0.9 | 3.8 | 0 | 2.3 | | | | | | | | | |

FROM CN732 OF FMB-012-1
To sheet 5/9 E-5

| Tr NO. | Q1 | Q5 | | | | |
|----------------------|----|-----|------|-----|-----|-----|
| PIN NO. | E | C | B | E | C | B |
| FM 87.5MHz NO SIGNAL | 0 | 7.1 | 0.85 | 8.9 | 8.8 | 0 |
| AM 522kHz NO SIGNAL | 0 | 0 | 0 | 9.0 | 0 | 8.9 |

| Tr NO. | Q2 | Q3 | Q4 | | | |
|---------------------|----|----|-----|---|-----|-----|
| PIN NO. | E | C | B | E | C | B |
| AM 522kHz NO SIGNAL | 0 | 0 | 0.7 | 0 | 0.7 | 0 |
| AM 144kHz NO SIGNAL | 0 | 0 | 0.3 | 0 | 0.3 | 0.3 |

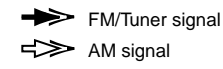

Parts are safety assurance parts. When replacing those parts make sure to use the specified one.

Printed circuit boards

■ DVD Servo control board

5

Forward side

4

3

2

1

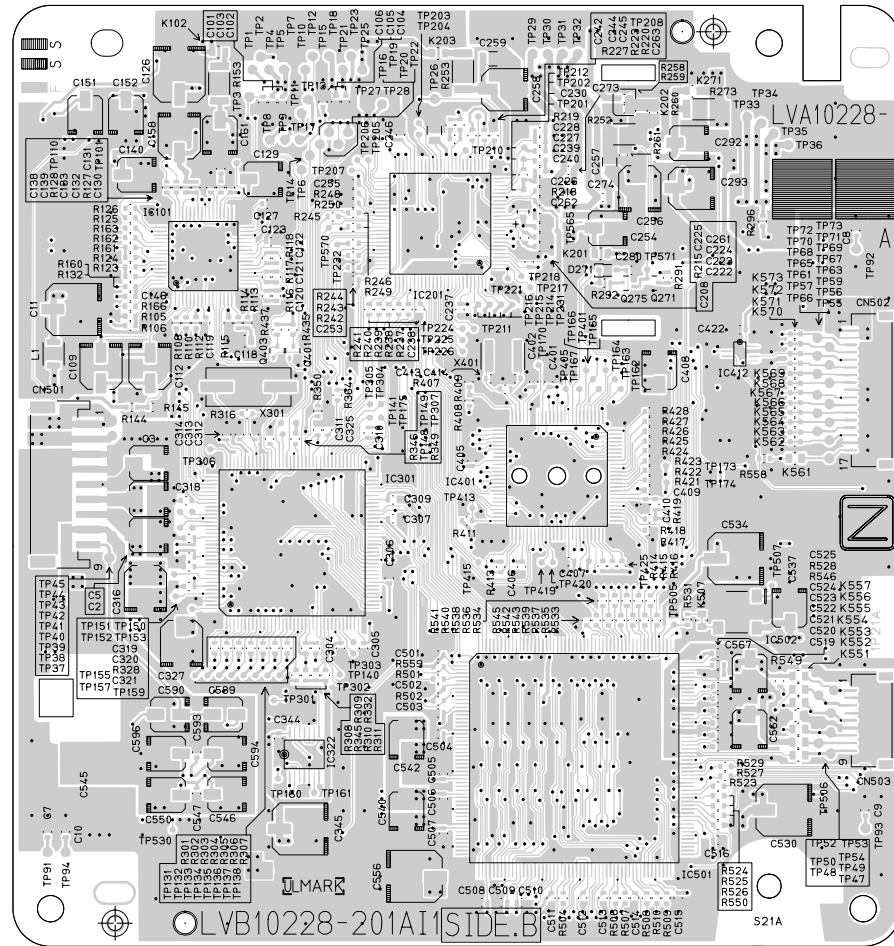

Reverse side

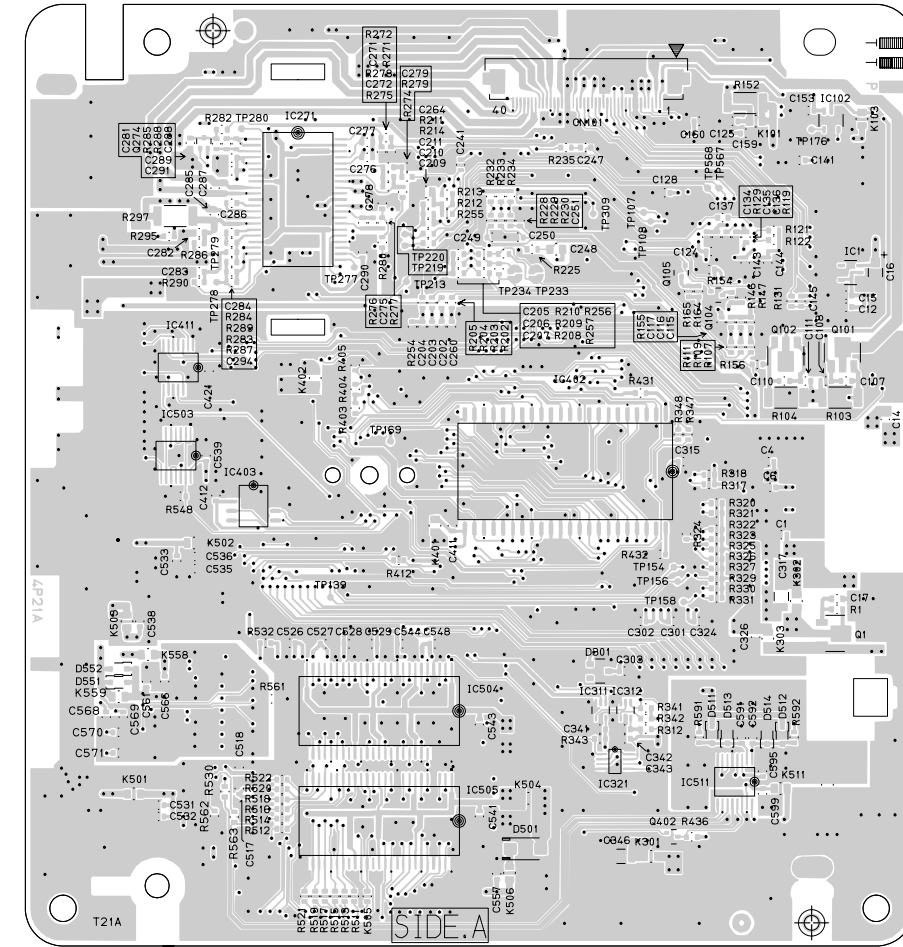

A

B

C

D

E

F

G

Amplifier, Regulator & Speaker terminal board

Speaker terminal board

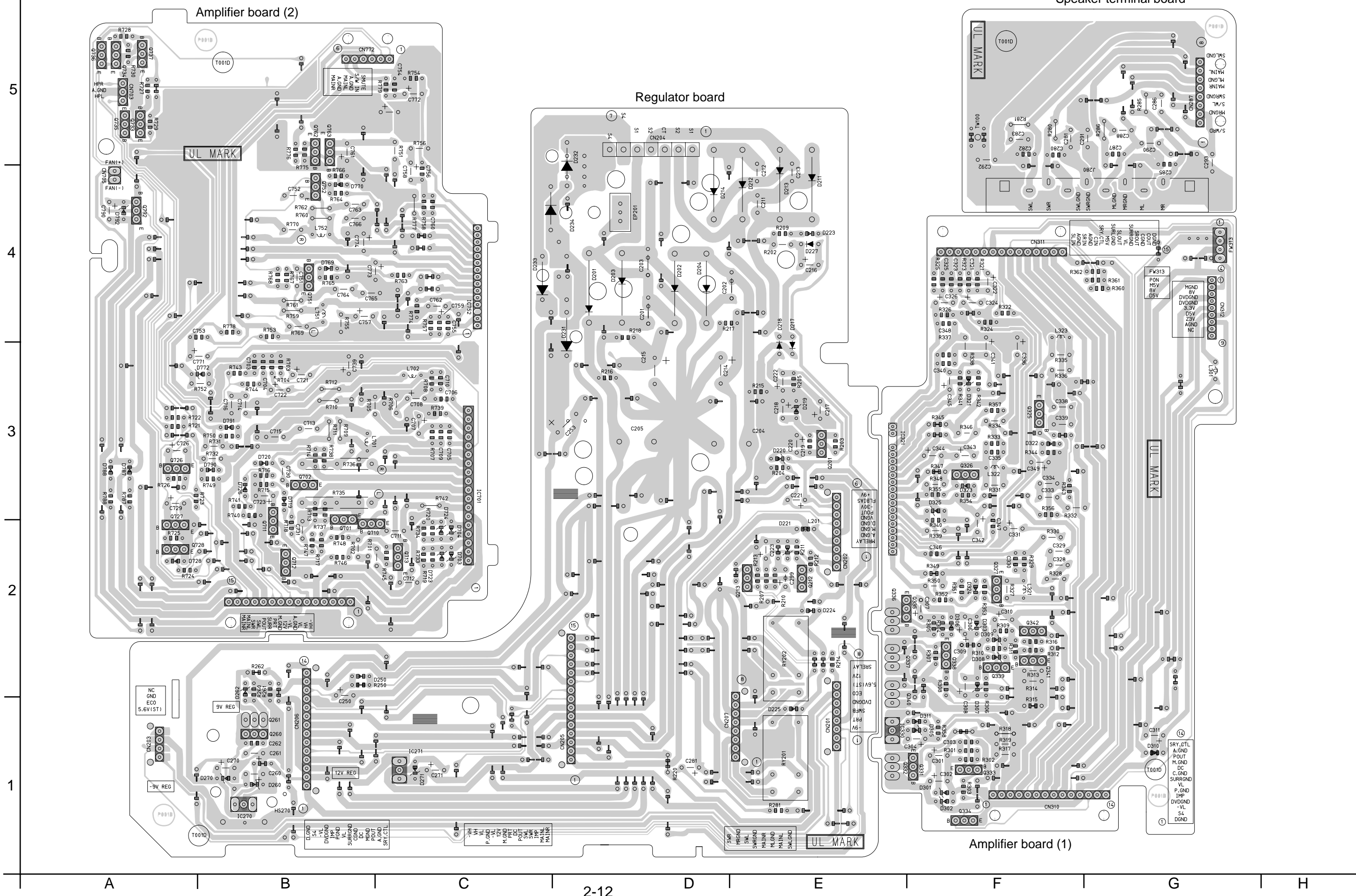

Amplifier board (2)

Regulator board

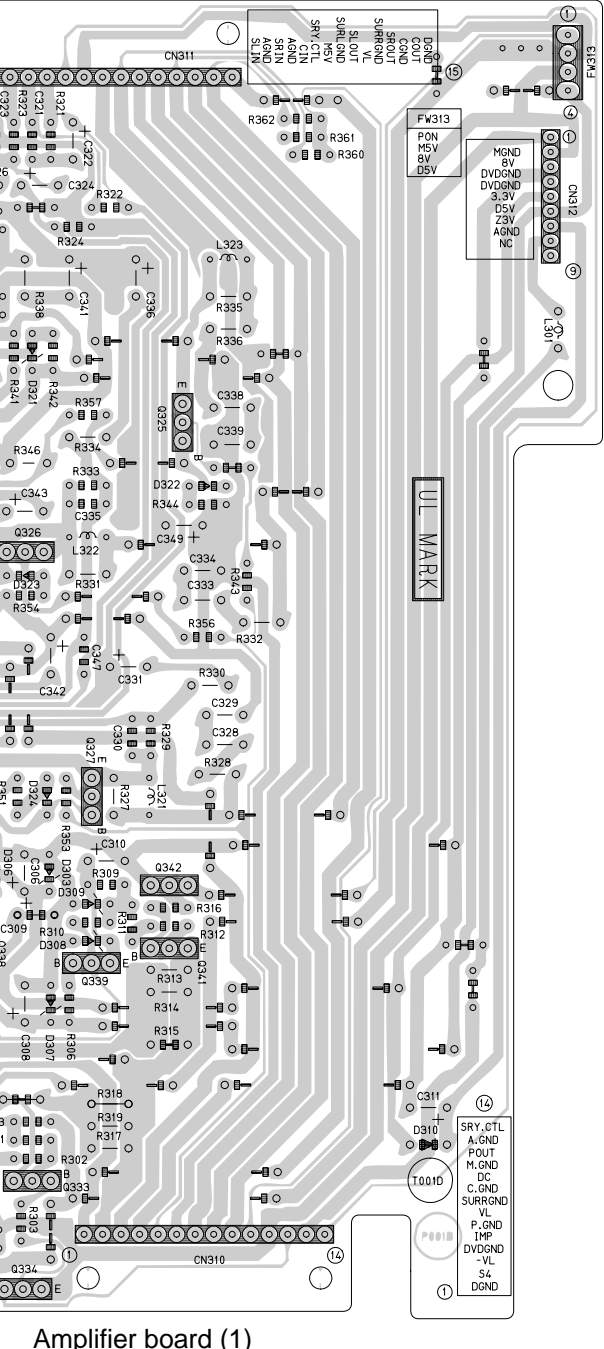
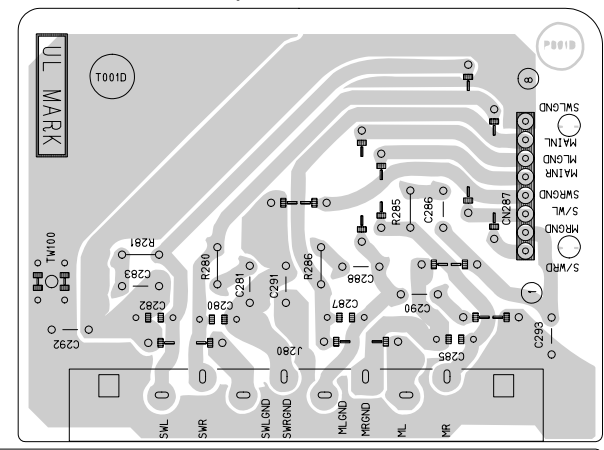

Amplifier board (1)

5

4

3

2

1

A

B

C

2-12

D

E

F

G

H

■ Main board

5

4

3

2

1

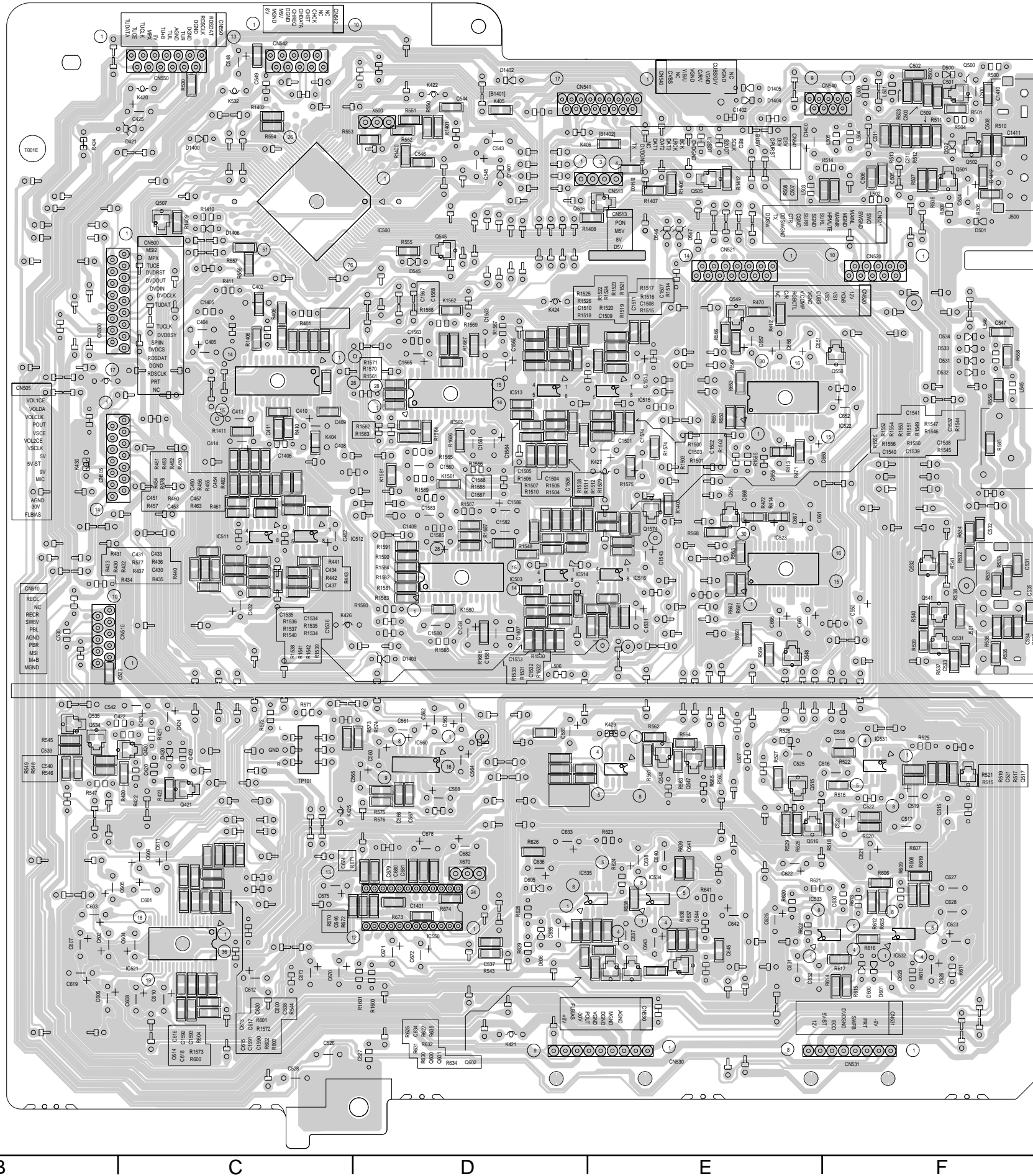

A

B

C

D

E

F

G

■ Front board

5

4

3

2

1

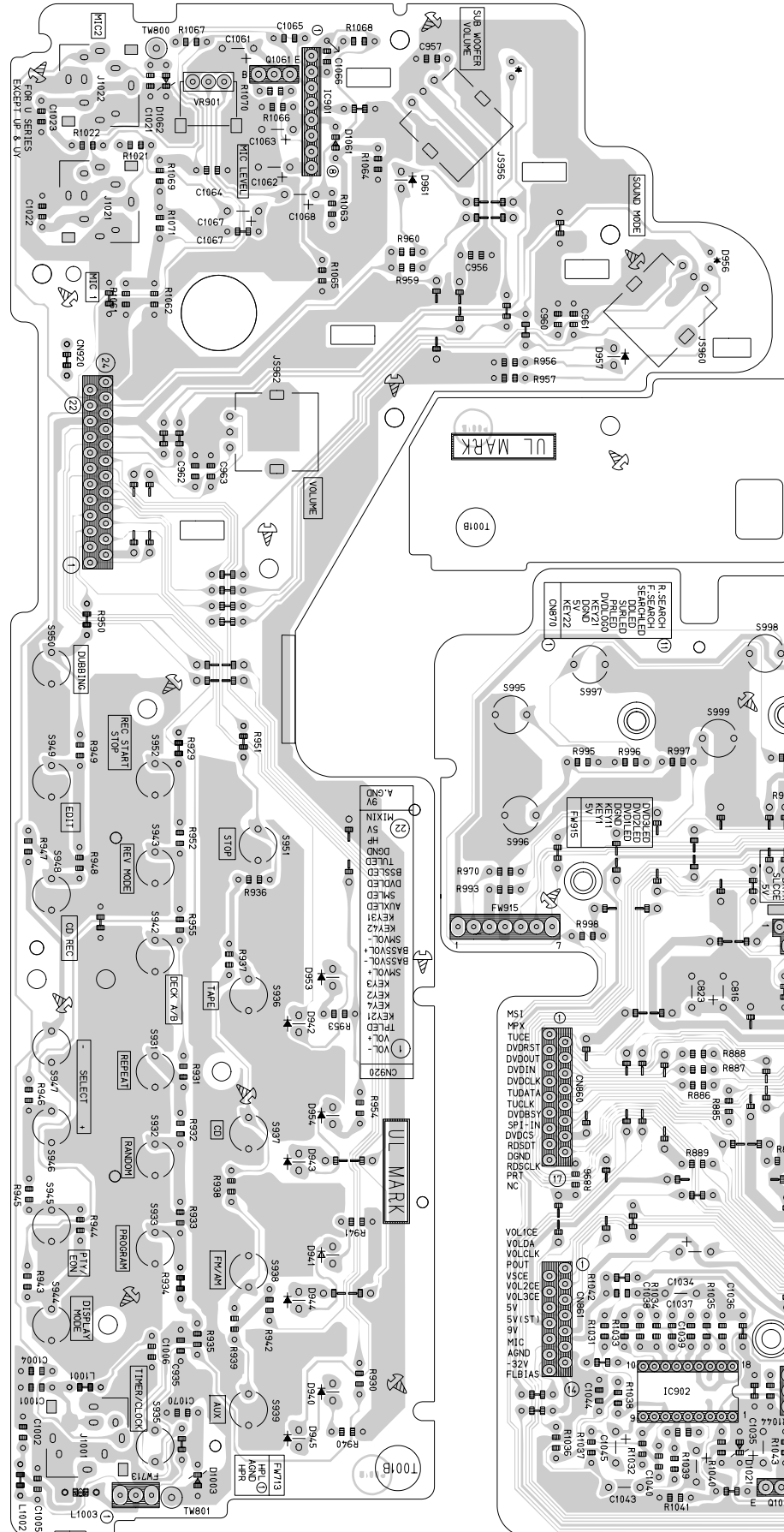

Operation switch board

DVD eject board

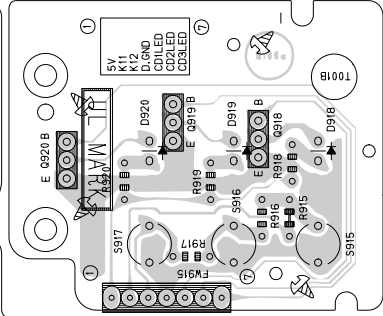

Preset / Tuning switch board

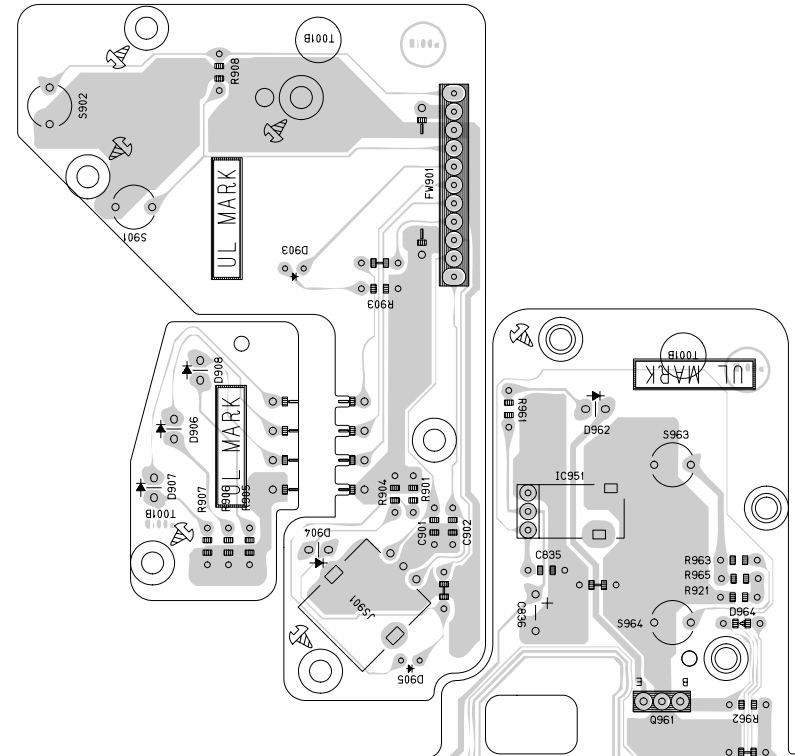

Display system control board

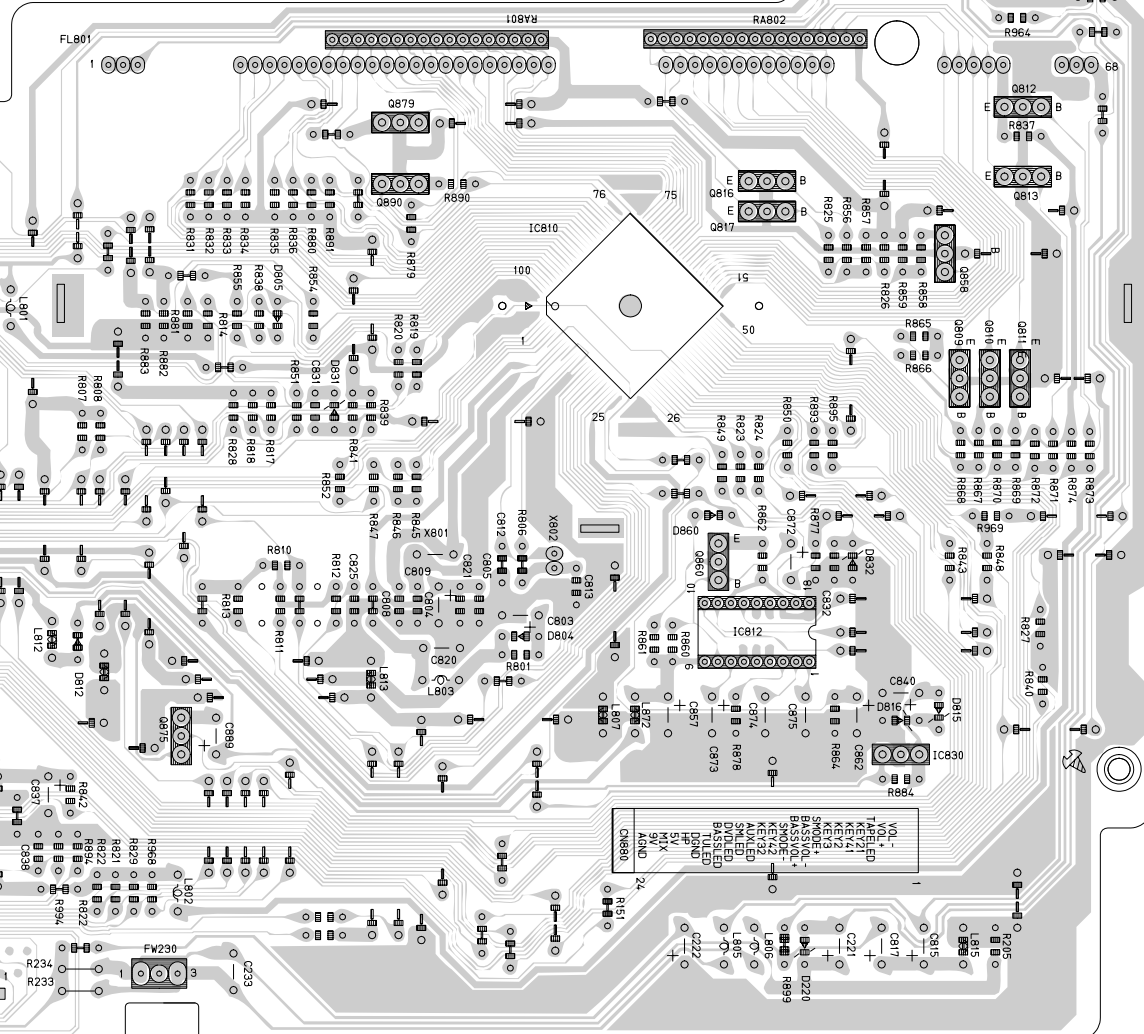

A

B

C

2-14

D

E

F

G

H

■ Power supply & AV output board

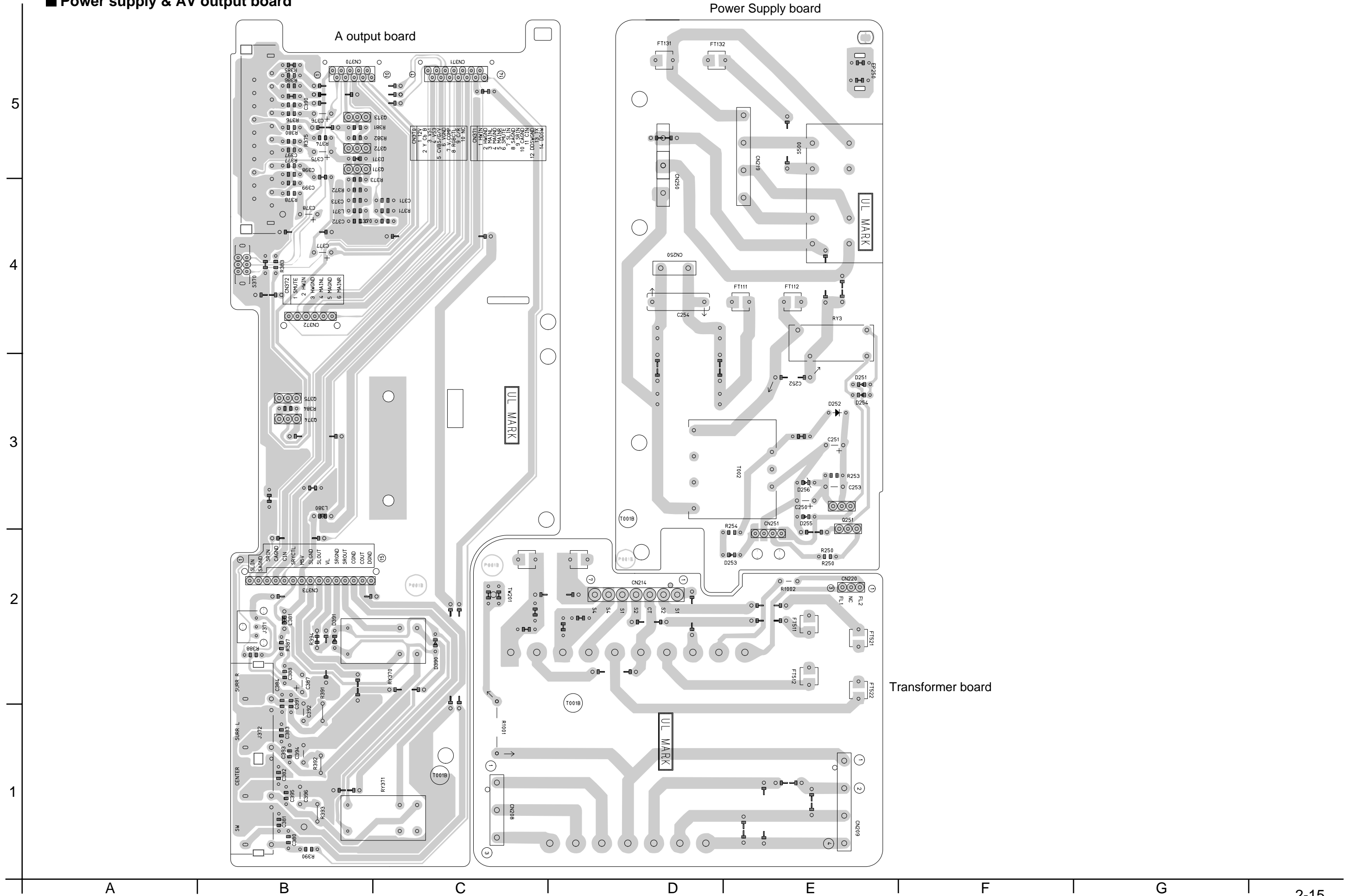

■ Tuner board

■ Head amplifier & mechanism board

5

4

3

2

1

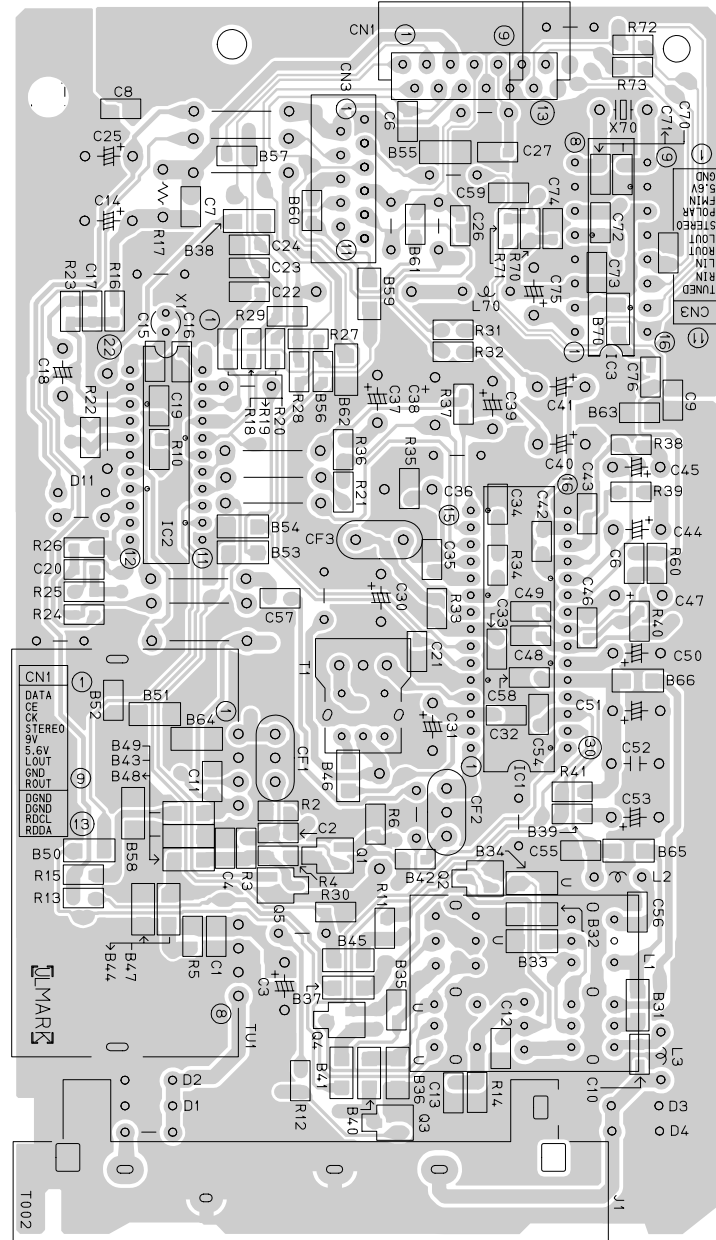

Head amplifier & mechanism board

Cassette switch board

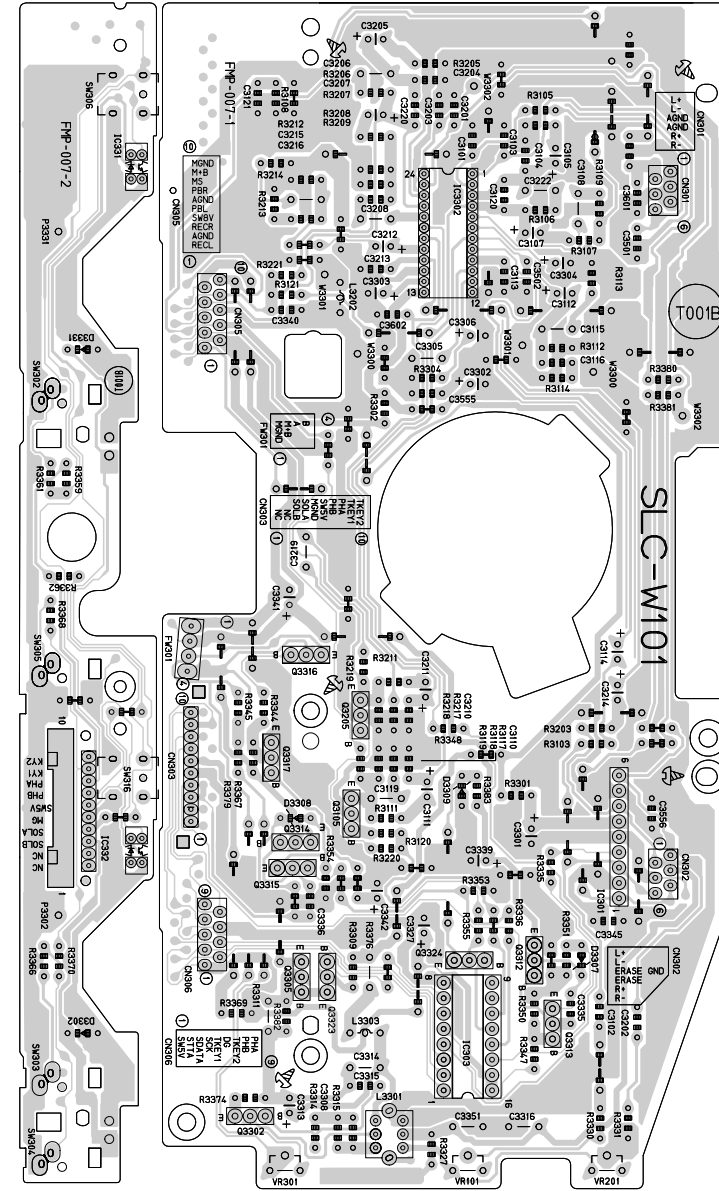

A

B

C

2-16

D

E

F

G

H

< M E M O >

MX-DVB10

JVC

VICTOR COMPANY OF JAPAN, LIMITED

AUDIO & COMMUNICATION BUSINESS DIVISION

PERSONAL & MOBILE NETWORK BUSINESS UNIT. 10-1,1chome,Ohwatari-machi,Maebashi-city,371-8543,Japan

No.21120SCH

 Printed in Japan
200209